

Network/Spectrum/Impedance Analyzer
HP 4396B

DECLARATION OF CONFORMITY

according to ISO/IEC Guide 22 and EN 45014

Manufacturer's Name: Hewlett-Packard Japan, Ltd.

Manufacturer's Address: 1-3-2, Murotani, Nishi-ku, Kobe-shi, Hyogo, 651-22 Japan

declares, that the product

Product Name: Network / Spectrum / Impedance Analyzer

Model Number(s): HP 4396B

Product Options: This declaration covers all options of the above product.

conforms to the following **Product Specifications:**

Safety: EN 61010-1:1993 / IEC 1010-1:1990+A1

EMC: CISPR 11:1990 / EN 55011:1991 - Group 1 Class A ¹⁾
EN 61000-3-2:1995 / IEC 1000-3-2:1995
EN 61000-3-3:1995 / IEC 1000-3-3:1994
EN 50082-1:1992
IEC 1000-4-2:1995 - 4 kV CD, 8 kV AD
IEC 801-3:1984 - 3 V/m
IEC 1000-4-4:1995 - 0.5 kV Signal Line, 1 kV Power Line

Supplementary Information:

The product herewith complies with the requirements of the EMC Directive 89/336/EEC and the Low Voltage Directive 73/23/EEC and carries the CE marking accordingly.

LEDs in this product are Class 1 in accordance with IEC 825-1.

1) The product was tested in a typical configuration.

Kobe, June 25, 1997

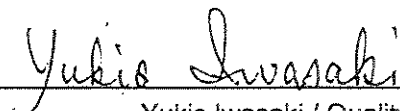

Yukio Iwasaki / Quality Manager

Herstellerbescheinigung

GERÄUSCHEMISSION

LpA < 70 dB
am Arbeitsplatz
normaler Betrieb
nach DIN 45635 T. 19

Manufacturer's Declaration

ACOUSTIC NOISE EMISSION

LpA < 70 dB
operator position
normal operation
per ISO 7779

**HP 4396B Network/Spectrum/Impedance
Analyzer**

Function Reference

SERIAL NUMBERS

This manual applies directly to instruments which have the serial number prefix JP1KE.

For additional important information about serial numbers, read "Serial Number" in Appendix A of this Manual.



HP Part No. 04396-90052

Printed in USA

September 1998

Fourth Edition

Notice

The information contained in this document is subject to change without notice.

This document contains proprietary information that is protected by copyright. All rights are reserved. No part of this document may be photocopied, reproduced, or translated to another language without the prior written consent of the Hewlett-Packard Company.

Hewlett-Packard Japan, LTD.
Kobe Instrument Division
1-3-2, Murotani, Nishi-ku, Kobe-shi,
Hyogo, 651-2241 Japan

Manual Printing History

The manual printing date and part number indicate its current edition. The printing date changes when a new edition is printed. (Minor corrections and updates that are incorporated at reprint do not cause the date to change.) The manual part number changes when extensive technical changes are incorporated.

March 1997	First Edition
July 1997	Second Edition
September 1997	Third Edition
September 1998	Fourth Edition

Certification

Hewlett-Packard Company certifies that this product met its published specifications at the time of shipment from the factory. Hewlett-Packard further certifies that its calibration measurements are traceable to the United States National Institute of Standards and Technology, to the extent allowed by the Institution's calibration facility, or to the calibration facilities of other International Standards Organization members.

Warranty

This Hewlett-Packard instrument product is warranted against defects in material and workmanship for a period of one year from the date of shipment, except that in the case of certain components listed in *General Information* of this manual, the warranty shall be for the specified period. During the warranty period, Hewlett-Packard Company will, at its option, either repair or replace products that prove to be defective.

For warranty service or repair, this product must be returned to a service facility designated by HP. Buyer shall prepay shipping charges to HP and HP shall pay shipping charges to return the product to Buyer. However, Buyer shall pay all shipping charges, duties, and taxes for products returned to HP from another country.

HP warrants that its software and firmware designated by HP for use with an instrument will execute its programming instruction when properly installed on that instrument. HP does not warrant that the operation of the instrument, or software, or firmware will be uninterrupted or error free.

Limitation Of Warranty

The foregoing warranty shall not apply to defects resulting from improper or inadequate maintenance by Buyer, Buyer-supplied software or interfacing, unauthorized modification or misuse, operation outside the environmental specifications for the product, or improper site preparation or maintenance.

No other warranty is expressed or implied. HP specifically disclaims the implied warranties of merchantability and fitness for a particular purpose.

Exclusive Remedies

The remedies provided herein are buyer's sole and exclusive remedies. HP shall not be liable for any direct, indirect, special, incidental, or consequential damages, whether based on contract, tort, or any other legal theory.

Assistance

Product maintenance agreements and other customer assistance agreements are available for Hewlett-Packard products.

For any assistance, contact your nearest Hewlett-Packard Sales and Service Office. Addresses are provided at the back of this manual.

Safety Summary

The following general safety precautions must be observed during all phases of operation, service, and repair of this instrument. Failure to comply with these precautions or with specific *WARNINGS* elsewhere in this manual may impair the protection provided by the equipment. In addition it violates safety standards of design, manufacture, and intended use of the instrument.

The Hewlett-Packard Company assumes no liability for the customer's failure to comply with these requirements.

Note



HP 4396B comply with INSTALLATION CATEGORY II and POLLUTION DEGREE 2 in IEC1010-1. HP 4396B are INDOOR USE product.

Note



LEDs in this product are Class 1 in accordance with IEC825-1.
CLASS 1 LED PRODUCT

Ground The Instrument

To avoid electric shock hazard, the instrument chassis and cabinet must be connected to a safety earth ground by the supplied power cable with earth blade.

DO NOT Operate In An Explosive Atmosphere

Do not operate the instrument in the presence of flammable gasses or fumes. Operation of any electrical instrument in such an environment constitutes a definite safety hazard.

Keep Away From Live Circuits

Operating personnel must not remove instrument covers. Component replacement and internal adjustments must be made by qualified maintenance personnel. Do not replace components with the power cable connected. Under certain conditions, dangerous voltages may exist even with the power cable removed. To avoid injuries, always disconnect power and discharge circuits before touching them.

DO NOT Service Or Adjust Alone

Do not attempt internal service or adjustment unless another person, capable of rendering first aid and resuscitation, is present.

DO NOT Substitute Parts Or Modify Instrument

Because of the danger of introducing additional hazards, do not install substitute parts or perform unauthorized modifications to the instrument. Return the instrument to a Hewlett-Packard Sales and Service Office for service and repair to ensure that safety features are maintained.

Dangerous Procedure Warnings

Warnings , such as the example below, precede potentially dangerous procedures throughout this manual. Instructions contained in the warnings must be followed.

Warning



Dangerous voltages, capable of causing death, are present in this instrument. Use extreme caution when handling, testing, and adjusting this instrument.

Safety Symbols

General definitions of safety symbols used on equipment or in manuals are listed below.



Instruction manual symbol: the product is marked with this symbol when it is necessary for the user to refer to the instruction manual.



Alternating current.



Direct current.



On (Supply).



Off (Supply).



In position of push-button switch.



Out position of push-button switch.



Frame (or chassis) terminal. A connection to the frame (chassis) of the equipment which normally include all exposed metal structures.

Warning



This **Warning** sign denotes a hazard. It calls attention to a procedure, practice, condition or the like, which, if not correctly performed or adhered to, could result in injury or death to personnel.

Caution



This **Caution** sign denotes a hazard. It calls attention to a procedure, practice, condition or the like, which, if not correctly performed or adhered to, could result in damage to or destruction of part or all of the product.

Note



This **Note** sign denotes important information. It calls attention to a procedure, practice, condition or the like, which is essential to highlight.



Affixed to product containing static sensitive devices use anti-static handling procedures to prevent electrostatic discharge damage to component.

Typeface Conventions

Bold

Boldface type is used when a term is defined. For example: **icons** are symbols.

Italics

Italic type is used for emphasis and for titles of manuals and other publications.

Italic type is also used for keyboard entries when a name or a variable must be typed in place of the words in italics. For example: *copy filename* means to type the word *copy*, to type a space, and then to type the name of a file such as *file1*.

Computer

Computer font is used for on-screen prompts and messages.

HARDKEYS

Labeled keys on the instrument front panel are enclosed in **□**.

SOFTKEYS

Softkeys located to the right of the CRT are enclosed in **↓**.

Documentation Map

The following manuals are available for the analyzer.

User's Guide (HP Part Number 04396-90031)

The User's Guide walks you through system setup and initial power-on, shows how to make basic measurements, explains commonly used features, and typical application measurement examples. After you receive your analyzer, begin with this manual.

Task Reference (HP Part Number 04396-90030)

Task Reference helps you to learn how to use the analyzer. This manual provides simple step-by-step instructions without concepts.

Function Reference (HP Part Number 04396-90052)

The Function Reference describes all function accessed from the front panel keys and softkeys. It also provides information on options and accessories available, specifications, system performance, and some topics about the analyzer's features.

Programming Guide (HP Part Number 04396-90033)

The Programming Guide shows how to write and use BASIC program to control the analyzer and describes how HP Instrument BASIC works with the analyzer.

HP-IB Command Reference (HP Part Number 04396-90034)

The HP-IB Command Reference provides a summary of all available HP-IB commands. It also provides information on the status reporting structure and the trigger system (these features conform to the SCPI standard).

Option 010 Operating Handbook (Option 010 only) (HP Part Number 04396-90036)

The option 010 Operation Handbook describes the unique impedance measurement functions of the HP 4396B with option 010.

HP Instrument BASIC Manual Set (HP Part Number E2083-90000)

The HP Instrument BASIC User's Handbook introduces you to the HP Instrument BASIC programming language, provide some helpful hints on getting the most use from it, and provide a general programming reference. It is divided into three books, *HP Instrument BASIC Programming Techniques*, *HP Instrument BASIC Interface Techniques*, and *HP Instrument BASIC Language Reference*.

Performance Test Manual (HP Part Number 04396-90120)

The Performance Test Manual explains how to verify conformance to published specifications.

Service Manual (Option 0BW only) (HP Part Number 04396-90121)

The Service Manual explains how to adjust, troubleshoot, and repair the instrument. This manual is option 0BW only.

Contents

1. Introduction	
Analyzer's Features	1-1
Front and Rear Panel	1-1
ACTIVE CHANNEL Block	1-1
ENTRY Block	1-2
MEASUREMENT Block	1-2
Network Analyzer Mode	1-2
Spectrum Analyzer Mode	1-2
SWEEP Block	1-3
MARKER Block	1-3
INSTRUMENT STATE Block	1-3
2. Front and Rear Panel	
Front Panel	2-1
1. Front Panel Keys and Softkeys	2-2
Softkeys that are Joined by Vertical Lines	2-2
Softkeys That Toggle On or Off	2-2
Softkeys that Show Status Indications in Brackets	2-2
2. HP-IB "REMOTE" Indicator	2-3
3. Preset	2-3
4. PROBE POWER Connector	2-3
5. Network Analyzer Inputs R, A, and B	2-3
6. RF OUT Connector	2-3
7. Spectrum Analyzer Input S	2-4
8. CAL OUT Connector	2-4
9. Built-in Flexible Disk Drive	2-4
10. LINE Switch	2-4
Screen display	2-4
1. Active Channel	2-5
2. Measured Input(s)	2-6
3. Format	2-6
4. Scale/Div	2-6
5. Reference Level	2-6
6. Marker Data Readout	2-6
7. Marker Statistics and Width Value	2-6
8. Softkey Labels	2-6
9. Pass/Fail	2-6
10. Sweep Time	2-7
11. Sweep Parameter Span/Stop Value	2-7
12. Power Level	2-7
13. CW Frequency	2-7
14. Video Bandwidth (VBW)	2-7
15. Input Attenuator	2-7
16. Sweep Parameter Center/Start Value	2-7

17. RBW/IFBW	2-7
18. Status Notations	2-8
19. External Reference	2-8
20. Active Entry Area	2-9
21. Message Area	2-9
22. Title	2-9
Rear Panel Features and Connectors	2-9
1. External Reference Input	2-10
2. Internal Reference Output	2-10
3. External Program RUN/CONT Input	2-10
4. I/O Port	2-10
5. Power	2-10
6. HP-IB Interface	2-10
7. External Monitor Terminal	2-10
8. Parallel Interface	2-10
9. mini DIN Keyboard Connector	2-10
10. Test Set I/O Interface	2-11
11. Gate Output (Option 1D6 Only)	2-11
12. External Trigger Input	2-11
13. 2nd IF Output	2-11
14. Reference Oven Output (Option 1D5 Only)	2-11
3. Active Channel Block	
Chan 1 (CHAN1) and Chan 2 (CHAN2)	3-1
Coupling Channels	3-2
4. Entry Block	
Numeric Keypad	4-2
Terminator Keys	4-2
Knob	4-2
↑ and ↓	4-2
Entry Off (KEY 18)	4-3
Back Space (KEY 19)	4-3
5. Measurement Block	
Meas	5-3
Input port menu	
Network Analyzer	5-5
NETWORK MEASUREMENT	5-5
NETWORK: A/R (MEAS AR)	5-5
B/R (MEAS BR)	5-5
R (MEAS R)	5-5
A (MEAS A)	5-5
B (MEAS B)	5-5
CONVERSION [OFF]	5-5
S-PARAMETERS	5-5
ANALYZER TYPE	5-5
S-parameter menu	
Network Analyzer	5-6
S-PARAMETER MEASUREMENT	5-6
Ref1: FWD S11 [A/R] (MEAS S11)	5-6

Trans: FWD S21 [B/R] (MEAS S21)	5-6
Trans: REV S12 [B/R] (MEAS S12)	5-6
Refl: REV S22 [A/R] (MEAS S22)	5-6
CONVERSION []	5-6
INPUT PORTS	5-6
ANALYZER TYPE	5-7
Input port menu	
Spectrum Analyzer	5-8
INPUT PORTS	5-8
SPECTRUM: S (MEAS S)	5-8
R (MEAS R)	5-8
A (MEAS A)	5-8
B (MEAS B)	5-8
DETECTION []	5-8
ANALYZER TYPE	5-8
Analyzer type menu	
Network Analyzer	
Spectrum Analyzer	5-9
NETWORK ANALYZER	5-9
NETWORK ANALYZER (NA)	5-9
SPECTRUM ANALYZER	5-9
SPECTRUM ANALYZER (SA)	5-9
Conversion menu	
Network Analyzer	5-10
OFF (CONV OFF)	5-10
IMPEDANCE	5-10
Z:Refl (CONV ZREF)	5-10
Z:Trans (CONV ZTRA)	5-10
ADMITTANCE	5-10
Y:Refl (CONV YREF)	5-10
Y:Trans (CONV YTRA)	5-10
1/S (CONV ONEDS)	5-10
MULTIPLE PHASE	5-11
4xPHASE (CONV MP4)	5-11
8xPHASE (CONV MP8)	5-11
16xPHASE (CONV MP16)	5-11
Detection menu	
Spectrum Analyzer	5-12
POSITIVE PEAK	5-12
POS PEAK (DET POS)	5-12
NEGATIVE PEAK	5-12
NEG PEAK (DET NEG)	5-12
SAMPLE	5-12
SAMPLE (DET SAM)	5-12
Format	5-13
Format menu	
Network Analyzer	5-14
LOG MAGNITUDE	5-14

FORMAT:LOG MAG (FMT LOGM)	5-14
PHASE	5-14
PHASE (FMT PHAS)	5-14
GROUP DELAY	5-14
DELAY (FMT DELA)	5-14
SMITH CHART	5-14
SMITH [Re Im] (FMT SMITH)	5-14
POLAR CHART	5-15
POLAR [Re Im] (FMT POLA)	5-15
LINEAR MAGNITUDE	5-15
LIN MAG (FMT LINM)	5-15
SWR	5-15
SWR (FMT SWR)	5-15
REAL	5-15
REAL (FMT REAL)	5-15
IMAGINARY	5-15
IMAGINARY (FMT IMAG)	5-15
EXPANDED PHASE	5-15
EXPANDED PHASE (FMT EXPP)	5-15
ADMITTANCE CHART	5-15
ADMITTANCE [Re Im] (FMT ADMIT)	5-15
Format menu	
Spectrum Analyzer	5-16
SPECTRUM MEASUREMENT	5-16
FORMAT:SPECTRUM (FMT SPECT)	5-16
NOISE MEASUREMENT	5-16
NOISE (FMT NOISE)	5-16
UNIT	5-16
UNIT: dBm (SAUNIT DBM)	5-16
dBV (SAUNIT DBV)	5-16
dB μ V (SAUNIT DBUV)	5-16
WATT (SAUNIT W)	5-16
VOLT (SAUNIT V)	5-16
Display	5-17
Display menu	
Network Analyzer	
Spectrum Analyzer	5-18
DUAL CHANNEL	5-18
DUAL CHAN on OFF (DUAC ON OFF)	5-18
DATA	5-18
DISPLAY: DATA (DISP DATA)	5-18
MEMORY	5-19
MEMORY (DISP MEMO)	5-19
DATA and MEMORY (DISP DATM)	5-19
DATA \rightarrow MEMORY (DATMEM)	5-19
DATA HOLD [] (DHOLD OFF MAX MIN)	5-19
MAX HOLD	5-19
MIN HOLD	5-19
DATA MATH	5-19
DATA MATH [] (MATH DATA DMNM DPLM DDVM)	5-19
DEFAULT GAIN & OFS (DEFGO)	5-19

OFFSET VALUE	5-20
OFFSET (DATOVAL)	5-20
MKR OFFSET (MKROFS)	5-20
AUX OFFSET VALUE (DATAOVAL)	5-20
GAIN	5-20
GAIN (DATGAIN)	5-20
SPLIT DISPLAY	5-20
SPLIT DISP ON off (SPLD ON OFF)	5-20
BASIC SCREEN	5-20
DISPLAY ALLOCATION (DISA	
ALLI HIHB ALLB BASS)	5-20
TITLE	5-21
TITLE (TITL)	5-21
ADJUST DISPLAY	5-21
FREQUENCY BLANK	5-21
FREQUENCY BLANK	5-21
Adjust display menu	
Network Analyzer	
Spectrum Analyzer	5-22
COLOR INTENSITY	5-22
INTENSITY (INTE)	5-22
BACKGROUND INTENSITY (BACI)	5-22
COLOR ADJUST	5-22
MODIFY COLORS	5-22
CH1 DATA (COLO CH1D)	5-22
CH1 MEM/LIMIT LINE (COLO CH1M)	5-23
CH2 DATA (COLO CH2D)	5-23
CH2 MEM/LIMIT LINE (COLO CH2M)	5-23
GRATICULE (COLO GRAT)	5-23
WARNING (COLO WARN)	5-23
TEXT MARKER (COLO TEXT)	5-23
IBASIC (COLO IBT)	5-23
PEN COLOR	5-23
PEN 1 (COLO PEN1)	5-23
PEN 2 (COLO PEN2)	5-23
PEN 3 (COLO PEN3)	5-23
PEN 4 (COLO PEN4)	5-23
PEN 5 (COLO PEN5)	5-24
PEN 6 (COLO PEN6)	5-24
DEFAULT COLORS (DEFC)	5-24
SAVE COLOR	5-24
SAVE COLORS (SVCO)	5-24
RECALL COLOR	5-24
RECALL COLORS (RECC)	5-24
Color adjust menu	
Network Analyzer	
Spectrum Analyzer	5-25

TINT (TINT)	5-25
BRIGHTNESS (CBRI)	5-25
COLOR (COLOR)	5-25
DEFAULT COLOR	5-25
RESET COLOR (RSCO)	5-25
Letter menu	
Network Analyzer	
Spectrum Analyzer	5-26
ENTER CHARACTERS	5-26
SELECT LETTER	5-26
SPACE	5-26
BACK SPACE	5-26
ERASE TITLE	5-26
DONE	5-26
CANCEL	5-26
Scale Ref	5-27
Scale reference menu	
Network Analyzer	5-27
AUTO SCALING	5-27
AUTO SCALE (AUTO)	5-27
SCALE/DIV (SCAL)	5-27
REFERENCE	5-27
REFERENCE POSITION (REFP)	5-27
REFERENCE VALUE (REFV)	5-27
MKR → REFERENCE (MKRREF)	5-28
SCALE FOR [] (SCAF DATA MEMO)	5-28
SCALE COUPLING	5-28
D&M SCALE [] (SCAC ON OFF)	5-28
ELECTRICAL DELAY	5-28
ELEC DELAY MENU	5-28
MKR → DELAY (MKRDELA)	5-28
ELECTRICAL DELAY (ELED)	5-28
PHASE OFFSET	5-28
PHASE OFFSET (PHAO)	5-28
Scale reference menu	
Spectrum Analyzer	5-29
AUTO ATTENUATOR	5-29
ATTEN AUTO man (ATTAUTO ON OFF)	5-29
ATTEN (ATT)	5-29
SCALE/DIV (SCAL)	5-29
REFERENCE	5-29
REFERENCE VALUE (REFV)	5-29
MKR → REFERENCE (MKRREF)	5-29
SCALE FOR [] (SCAF DATA MEMO)	5-29
SCALE COUPLING	5-30
D&M SCALE [] (SCAC ON OFF)	5-30
MAX MIXER LEVEL	5-30
MAX MIXER LEVEL (MAXMLEV)	5-30

Bw/Avg	5-31
Bandwidth menu	
Network Analyzer	5-31
AVERAGING	5-31
AVERAGING RESTART (AVERREST)	5-31
AVERAGING on OFF (AVER ON OFF)	5-31
AVERAGING FACTOR (AVERFACT)	5-31
IF BANDWIDTH	5-32
IF BW (BW)	5-32
GROUP DELAY APERTURE	5-32
GROUP DELY APERTURE (GRODAPER)	5-32
Bandwidth menu	
Spectrum Analyzer	5-33
AVERAGING	5-33
AVERAGING RESTART (AVERREST)	5-33
AVERAGING on OFF (AVER ON OFF)	5-33
AVERAGING FACTOR (AVERFACT)	5-33
RESOLUTION BANDWIDTH	5-33
RES BW AUTO man (BWAUTO ON OFF)	5-33
RES BW [] (BW)	5-34
RBW/SPAN RATIO (BWSRAT)	5-34
VIDEO BANDWIDTH	5-34
VBW TYPE [] (VBW)	5-34
VIDEO BW (VBW)	5-34
Cal	5-35
Calibration menu	
Network Analyzer	5-37
CORRECTION ON OFF	5-37
CORRECTION on OFF	5-37
CALIBRATE MENU	5-38
CALIBRATE:NONE (CALI NONE)	5-38
RESPONSE	5-39
RESPONSE (CALI RESP)	5-39
RESPONSE AND ISOLATION	5-39
RESPONSE & ISOL'N (CALI RAI)	5-39
1-PORT CAL	5-39
S11 1-PORT (CALI S111)	5-39
S22 1-PORT (CALI S221)	5-39
2-PORT CAL	5-40
FULL 2-PORT (CALI FUL2)	5-40
ONE PATH 2-PORT (CALI ONE2)	5-40
RESUME CAL	5-40
RESUME CAL SEQUENCE (RESC)	5-40
CAL KIT	5-40
CAL KIT [7mm]	5-40
CAL KIT:7mm (CALK APC7)	5-40
3.5mm (CALK APC35)	5-40
N 50 ohm (CALK N50)	5-40
N 75 ohm (CALK N75)	5-41

USER CAL KIT	5-41
USER KIT (CALK USED)	5-41
SAVE USER KIT (SAVEUSEK)	5-41
MODIFY CAL KIT	5-41
MODIFY [] (MODI1)	5-41
PORT EXTENSION	5-41
PORT EXTENSIONS	5-41
VELOCITY FACTOR	5-41
VELOCITY FACTOR (VELOFACT)	5-41
CHARACTERISTIC IMPEDANCE	5-41
SET Z0 (SETZ)	5-41
Response standard menu	
Network Analyzer	5-43
RESPONSE FOR 3.5 MM/7MM CAL KITS	5-43
SHORT (STANA)	5-43
OPEN (STANB)	5-43
THRU (STANC)	5-43
RESPONSE FOR TYPE-N CAL KITS	5-43
SHORT [M] (STANA)	5-43
SHORT [F] (STANB)	5-43
OPEN [M] (STANC)	5-44
OPEN [F] (STAND)	5-44
THRU (STANE)	5-44
RESPONSE FOR USER CAL KIT	5-44
defined std 1 (STANA)	5-44
defined std 2 (STANB)	5-44
defined std 3 (STANC)	5-44
defined std 4 (STAND)	5-44
defined std 5 (STANE)	5-44
defined std 6 (STANF)	5-44
defined std 7 (STANG)	5-44
DONE: RESPONSE (RESPDONE)	5-44
Response/Isolation Menu	
Network Analyzer	5-45
RESPONSE	5-45
RESPONSE (RAIRESP)	5-45
ISOLATION	5-45
ISOL'N STD (RAIISOL)	5-45
DONE RESP ISOL'N CAL (RAID)	5-45
S11 1-Port Menu	
Network Analyzer	5-46
s11 1-PORT CAL	5-46
[S11]: OPEN (CLASS11A)	5-46
SHORT (CLASS11B)	5-46
LOAD (CLASS11C)	5-46
DONE: 1-PORT CAL (SAV1)	5-46

S22 1-Port Menu	
Network Analyzer	5-47
S22 1-PORT CAL	5-47
[S22]: OPEN (CLASS22A)	5-47
SHORT (CLASS22B)	5-47
LOAD (CLASS22C)	5-47
DONE: 1-PORT CAL (SAV1)	5-47
Full 2-Port Cal Menu	
Network Analyzer	5-48
REFLECTION CAL	5-48
REFLECT'N (REFL)	5-48
[S11]: OPEN (CLASS11A)	5-48
SHORT (CLASS11B)	5-48
LOAD (CLASS11C)	5-49
[S22]: OPEN (CLASS22A)	5-49
SHORT (CLASS22B)	5-49
LOAD (CLASS22C)	5-49
REFLECT'N DONE (REFD)	5-49
TRANSMISSION CAL	5-49
TRANS-MISSION (TRANS)	5-49
FWD. TRANS. THRU (FWDT)	5-49
FWD. MATCH THRU (FWDM)	5-49
REV. TRANS. THRU (REVT)	5-50
REV. MATCH THRU (REVM)	5-50
TRANS. DONE (TRAD)	5-50
ISOLATION	5-50
ISOLATION (ISOL)	5-50
OMIT ISOLATION (OMII)	5-50
FWD.ISOL'N ISOL'N STD (FWDI)	5-50
REV.ISOL'N ISOL'N STD (REVI)	5-50
ISOLATION DONE (ISOD)	5-50
DONE: 2-PORT CAL (SAV2)	5-51
One-Path 2-Port Menu	
Network Analyzer	5-52
REFLECTION CAL	5-52
REFLECT'N (REFL)	5-52
[S11]: OPEN (CLASS11A)	5-52
SHORT (CLASS11B)	5-52
LOAD (CLASS11C)	5-52
REFLECT'N DONE (REFD)	5-53
TRANSMISSION CAL	5-53
TRANS-MISSION (TRAN)	5-53
FWD. TRANS. THRU (FWDT)	5-53
FWD. MATCH THRU (FWDM)	5-53
TRANS. DONE (TRAD)	5-53

ISOLATION	5-53
ISOLATION (ISOL)	5-53
OMIT ISOLATION (OMII)	5-53
FWD.ISOL'N ISOL'N STD (FWDI)	5-53
REV.ISOL'N ISOL'N STD (REVI)	5-53
ISOLATION DONE (ISOD)	5-54
DONE: 2-PORT CAL (SAV2)	5-54
Reference Plane Menu	
Network Analyzer	5-55
PORT EXTENSION	5-55
EXTENSIONS on OFF (PORE ON OFF)	5-55
EXTENSION INPUT R (PORTR)	5-55
EXTENSION INPUT A (PORTA)	5-55
EXTENSION INPUT B (PORTB)	5-55
EXTENSION PORT 1 (PORT1)	5-55
EXTENSION PORT 2 (PORT2)	5-55
Modify Cal Kit Menu	
Network Analyzer	5-56
DEFINE STANDARD	5-56
DEFINE STANDARD	5-56
STD NO.1 [] (DEFS 1)	5-57
STD NO.2 [] (DEFS 2)	5-57
STD NO.3 [] (DEFS 3)	5-57
STD NO.4 [] (DEFS 4)	5-57
STD NO.5 [] (DEFS 5)	5-57
STD NO.6 [] (DEFS 6)	5-57
STD NO.7 [] (DEFS 7)	5-57
STD NO.8 [] (DEFS 8)	5-57
SPECIFY CLASS	5-57
SPECIFY CLASS	5-57
SPECIFY: S11A (SPECS11A)	5-57
S11B (SPECS11B)	5-57
S11C (SPECS11C)	5-58
SPECIFY: S22A (SPECS22A)	5-58
S22B (SPECS22B)	5-58
S22C (SPECS22C)	5-58
SPECIFY: FWD.TRANS. (SPECFWDT)	5-58
REV.TRANS. (SPECREVT)	5-58
FWD.MATCH (SPECFWDM)	5-58
REV.MATCH (SPECREVM)	5-58
RESPONSE (SPECRESP)	5-58
RESPONSE & ISO'N (SPECRESI)	5-58
CLASS DONE (SPEC'D) (CLAD)	5-59

LABEL CLASS	5-59
LABEL CLASS	5-59
LABEL: S11A (LABES11A)	5-59
S11B (LABES11B)	5-59
S11C (LABES11C)	5-59
LABEL: S22A (LABES22A)	5-59
S22B (LABES22B)	5-59
S22C (LABES22C)	5-59
LABEL: FWD TRANS (LABEFWDT)	5-59
REV TRANS (LABEREVT)	5-59
FWD MATCH (LABEFWDM)	5-59
REV MATCH (LABEREVM)	5-60
RESPONSE (LABERESP)	5-60
RESPONSE & ISO'N (LABERESI)	5-60
LABEL DONE	5-60
LABEL CAL KIT	5-60
LABEL KIT (LABK)	5-60
KIT DONE (MODIFIED) (KITD)	5-60
Specify offset menu	
Network Analyzer	5-61
OFFSET DELAY	5-61
OFFSET DELAY	5-61
OFFSET LOSS	5-61
OFFSET LOSS	5-61
CHARACTERISTIC IMPEDANCE	5-61
OFFSET ZO (OFSZ)	5-61
STD OFFSET DONE	5-61
Standard Type menu	
Network Analyzer	5-62
OPEN	5-62
STD TYPE: OPEN (STDT OPEN)	5-62
C0 (C0)	5-63
C1 (C1)	5-63
C2 (C2)	5-63
SHORT	5-63
SHORT (STDT SHOR)	5-63
LOAD	5-63
LOAD (STDT LOAD)	5-63
DELAY/THRU	5-63
DELAY/THRU (STDT DELA)	5-63
ARBITRARY IMPEDANCE	5-64
ARBITRARY IMPEDANCE (STDT ARBI)	5-64
TERMINAL IMPEDANCE (TERI)	5-64
SPECIFY OFFSET	5-64
LABEL STANDARD	5-64
LABEL STD (LABS)	5-64

STD DONE (DEFINED) (STDD)	5-64
Calibration menu	
Spectrum Analyzer	5-65
LEVEL CAL	5-65
EXECUTE LVL CAL (LVLCAL)	5-65
LVL CAL DATA (LVCDT)	5-65
INPUT IMPEDANCE	5-65
INPUT Z (INPZ)	5-65

6. Sweep Block

Sweep	6-2
Sweep menu	
Network Analyzer	6-3
SWEEP TIME	6-3
SWEEP TIME AUTO man (SWETAUTO ON OFF)	6-3
SWEEP TIME (SWET)	6-3
:h:m:s	6-3
DISPLAY POINTS	6-3
NUMBER of POINTS (POIN)	6-3
CHANNEL COUPLING	6-3
COUPLED CH ON off (COUC ON OFF)	6-3
SWEEP TYPE MENU (SWPT LINF LOGF LIST POWE)	6-4
LINEAR SWEEP	6-4
LOG SWEEP	6-4
LIST SWEEP	6-4
POWER SWEEP	6-4
LIST TABLE	6-4
EDIT LIST (EDITLIST)	6-4
SEGMENT	6-4
EDIT (SEDI)	6-4
DELETE (SDEL)	6-4
ADD (SADD)	6-4
CLEAR LIST (CLEL)	6-4
LIST DONE (EDITDONE)	6-5
Sweep menu	
Spectrum Analyzer	6-6
SWEEP TIME	6-6
SWEEP TIME AUTO man (SWETAUTO)	6-6
SWEEP TIME (SWET)	6-6
:h:m:s	6-6
SAMPLING	6-7
SAMPLING NORMAL repet (REPTSMP OFF ON)	6-7
DISPLAY POINT	6-7
NUMBER of POINTS (POIN)	6-7
SWEEP TYPE MENU	6-7
LINEAR SWEEP	6-7
SWEEP TYPE:LIN FREQ (SWPT LINF)	6-7
LIST SWEEP	6-8
LIST FREQ (SWPT LIST)	6-8

LIST TABLE	6-8
EDIT LIST (EDITLIST)	6-8
SEGMENT	6-8
EDIT (SEDI)	6-8
DELETE (SDEL)	6-8
ADD (SADD)	6-8
CLEAR LIST (CLEL)	6-8
LIST DONE (EDITDONE)	6-8
Clear list menu	
Network Analyzer	
Spectrum Analyzer	6-10
CLEAR LIST	6-10
CLEAR LIST YES	6-10
NO	6-10
Segment menu	
Network Analyzer	6-11
SEGMENT	6-11
SEGMENT: MKR→START (MKRSTAR)	6-11
MKR→STOP (MKRSTOP)	6-11
NUMBER of POINTS (POIN)	6-11
STEP SIZE (STPSIZE)	6-11
POWER (POWER)	6-11
IF BW (BW)	6-12
MORE	6-12
SEGMENT: START (STAR)	6-12
STOP (STOP)	6-12
CENTER (CENT)	6-12
SPAN (SPAN)	6-12
SEGMENT QUIT (SQUI)	6-12
SEGMENT DONE (SDON)	6-12
Segment menu	
Spectrum Analyzer	6-13
SEGMENT: MKR→START (MKRSTAR)	6-13
MKR→STOP (MKRSTOP)	6-13
POWER (POWER)	6-13
RES BW (BW)	6-13
MORE	6-13
SEGMENT: START (STAR)	6-13
STOP (STOP)	6-13
CENTER (CENT)	6-14
SPAN (SPAN)	6-14
SEGMENT QUIT (SQUI)	6-14
SEGMENT DONE (SDON)	6-14
Source	6-15

Source menu	
Network Analyzer	6-15
POWER LEVEL	6-15
POWER (POWE)	6-15
SLOPING	6-15
SLOPE (SLOPE)	6-15
SLOPE on OFF (SLOP ON OFF)	6-15
FREQUENCY FOR POWER SWEEP	6-15
CW FREQ (CWFREQ)	6-15
ATTENUATORS	6-15
ATTENUATOR PORT 1 (ATTP1)	6-15
ATTENUATOR PORT 2 (ATTP2)	6-16
RF OUT ON off (RFO ON OFF)	6-16
Source menu	
Spectrum Analyzer	6-17
POWER (POWE)	6-17
RF OUT on OFF (RFO ON OFF)	6-17
Trigger	6-18
Trigger menu	
Network Analyzer	
Spectrum Analyzer	6-18
TRIGGER TYPE	6-18
SWEEP:HOLD (HOLD)	6-18
SINGLE (SING)	6-18
NUMBER of GROUPS (NUMG)	6-18
CONTINUOUS (CONT)	6-19
TRIGGER SOURCE	6-19
TRIGGER: [FREE RUN] (TRGS	
INT EXT VID MAN GAT)	6-19
GATE TRIGGER	6-19
GATE[LEVEL] (GATCTL LEV EDG)	6-19
GATE DELAY (GATDLY)	6-19
GATE LENGTH (GATLEN)	6-19
TRIGGER EVENT	6-20
TRIG EVENT [] (TRGEVE POIN SWE)	6-20
TRIGGER POLARITY	6-20
TRIG PLRTY POS neg (TRGP POS NEG)	6-20
RESTART SWEEP	6-20
MEASURE RESTART (REST)	6-20
Start Stop (STAR, STOP)	6-21
Center (CENT)	6-22
Center menu	
Network Analyzer	
Spectrum Analyzer	6-22
CENTER STEP SIZE	6-22
STEP SIZE AUTO man (CNTSAUTO ON OFF)	6-22
CENTER STEP SIZE (CNTS)	6-22
MKR→CNTR STEP (MKRCSTE)	6-22
MKRA→CNTR STEP (MKRDCSTE)	6-22

<u>MKR</u> → CENTER (MKRCENT)	6-22
<u>MKRSΔ</u> → CENTER (MKRDCEM)	6-22
<u>PEAK</u> → CENTER (PEAKCENT)	6-23
<u>Span</u> (SPAN)	6-24
Span menu	
Network Analyzer	
Spectrum Analyzer	6-24
FULL SPAN	6-24
<u>FULL SPAN</u> (FULS)	6-24
ZERO SPAN	6-24
<u>ZERO SPAN</u> (SPAN 0)	6-24
<u>MKRA</u> → SPAN (MKRDSPAN)	6-24

7. Marker Block

<u>Marker</u> (MKR ON)	7-2
Marker menu	
Network Analyzer	
Spectrum Analyzer	7-3
<u>SUB MKR</u> (SKR [1-7] ON)	7-3
CLEAR MARKERS	7-3
<u>CLEAR SUB MKR</u> (SMKR [1-7] OFF)	7-3
<u>PRESET MKRS</u> (PRSMKRS)	7-3
<u>MKR ON</u> [] (MKRO DATA MEMO)	7-3
MARKER COUPLING	7-3
<u>MKR</u> [] (MKRCOUP OFF ON)	7-3
CONTINUOUS	7-4
DISCRETE	7-4
<u>MKR</u> [] (MKRCONT ON OFF)	7-4
<u>ΔMODE MENU</u>	7-4
Delta mode menu	
Network Analyzer	
Spectrum Analyzer	7-5
<u>ΔMARKER</u>	7-5
<u>ΔMKR</u> (DMKR ON)	7-5
<u>FIXED ΔMKR</u> (DMKR FIX)	7-5
TRACKING ΔMARKER	7-5
<u>TRACKING ΔMKR</u> (DMKR TRAC)	7-5
<u>ΔMODE OFF</u> (DMKR OFF)	7-5
FIXED ΔMARKER	7-6
<u>ΔMKR SWP PARAM</u> (DMKRPRM)	7-6
<u>FIXEDΔMKR VALUE</u> (DMKRVAL)	7-6
<u>FIXEDΔMKR AUX VALUE</u> (DMKRAUV)	7-6
Sub-marker menu	
Network Analyzer	
Spectrum Analyzer	7-7
SUB-MARKER	7-7
<u>SUB MKR 1</u> (SMKR1 ON)	7-7
<u>2</u> (SMKR2 ON)	7-7
<u>3</u> (SMKR3 ON)	7-7

4 (SMKR4 ON)	7-7
5 (SMKR5 ON)	7-7
6 (SMKR6 ON)	7-7
7 (SMKR7 ON)	7-7
Clear Sub-marker menu	
Network Analyzer	
Spectrum Analyzer	7-8
CLEAR SUB-MARKER	7-8
SUB MKR 1 (SMKR1 OFF)	7-8
2 (SMKR2 OFF)	7-8
3 (SMKR3 OFF)	7-8
4 (SMKR4 OFF)	7-8
5 (SMKR5 OFF)	7-8
6 (SMKR6 OFF)	7-8
7 (SMKR7 OFF)	7-8
Marker⇒	7-9
Marker→ menu	
Network Analyzer	
Spectrum Analyzer	7-10
MKR→ FUNCTION	7-10
MKR→CENTER (MKRCENT)	7-10
MKR→START (MKRSTAR)	7-10
MKR→STOP (MKRSTOP)	7-10
MKR→REFERENCE (MKRREF)	7-10
MKR ZOOM (MKRZM)	7-10
PEAK→CENTER (PEAKCENT)	7-11
ZOOMING	7-11
ZOOMING APERTURE (ZMAPER)	7-11
ΔMARKER→FUNCITON	7-11
MKRA→SPAN (MKRDSPAN)	7-11
MKRA→CENTER (MKRDCENT)	7-11
CROSS CHANNEL	7-11
CROSS CHAN on OFF (CRSC ON OFF)	7-11
Search	7-12
Search menu	
Network Analyzer	
Spectrum Analyzer	7-14
PEAK SEARCH	7-15
SEARCH: PEAK (SEAM PEAK)	7-15
MAX SEARCH	7-15
MAX (SEAM MAX)	7-15
MIN SEARCH	7-15
MIN (SEAM MIN)	7-15
TARGET SEARCH	7-15
TARGET (SEAM TARG)	7-15
MULTIPLE PEAKS	7-15
PEAK ALL	7-15
SEARCH: PEAKS ALL (SEAM PKSA)	7-15

PEAKS RIGHT (SEAM PKSR)	7-15
PEAKS LEFT (SEAM PKSL)	7-15
PEAK DEF MENU	7-15
SEARCH TRACK	7-16
SEARCH TRK on OFF (TRACK ON OFF)	7-16
WIDTH	7-16
WIDTHS [] (WIDT ON OFF)	7-16
SIGNAL TRACK	7-16
SIGNAL TRK on OFF (SGTRK ON OFF)	7-16
SEARCH RANGE MENU	7-17
Peak menu	
Network Analyzer	
Spectrum Analyzer	7-18
PEAK (SEAM PEAK)	7-18
NEXT PEAK	7-18
NEXT PEAK (SEANPK)	7-18
LEFT PEAK	7-18
NEXT PEAK LEFT (SEANPKL)	7-18
RIGHT PEAK	7-18
NEXT PEAK RIGHT (SEANPKR)	7-18
SIGNAL TRK on OFF (SGTRK ON OFF)	7-18
PEAK DEF MENU	7-18
SUB MKR	7-18
Target Menu	
Network Analyzer	7-19
TARGET SEARCH	7-19
TARGET (SEATARG)	7-19
SEARCH LEFT (SEAL)	7-19
SEARCH RIGHT (SEAR)	7-19
SUB MKR	7-19
Widths Menu	
Network Analyzer	7-20
WIDTH FUNCTION	7-20
SEARCH IN (WIDSIN)	7-20
SEARCH OUT (WIDSOUT)	7-20
WIDTHS on OFF (WIDT ON OFF)	7-20
WIDTH VALUE (WIDV)	7-20
Peak definition menu	
Network Analyzer	7-22
THRESHOLD	7-22
THRESHOLD on OFF (PKTHRE ON OFF)	7-22
THRESHOLD VALUE (PKTHVAL)	7-22
MKR THRESHOLD (MKRTHRE)	7-22
PEAK POLARITY	7-22
PEAK PLRITY POS neg (PKPOL POS NEG)	7-22
PEAK DELTA	7-22
PEAK DELTA: ΔX (PKDLTX)	7-22
PEAK DELTA: ΔY (PKDLTY)	7-22

MKR → PEAK DELTA (MKRPKD)	7-22
Peak definition menu	
Spectrum Analyzer	7-24
THRESHOLD	7-24
THRESHOLD on OFF (PKTHRE ON OFF)	7-24
THRESHOLD VALUE (PKTHVAL)	7-24
MKR → THRESHOLD (MKRTHRE)	7-24
PEAK DEF:ΔY (PKDLTY)	7-24
Search range menu	
Network Analyzer	
Spectrum Analyzer	7-25
SEARCH RANGE	7-25
PART SRCH on OFF (PARS ON OFF)	7-25
MKRA → SEARCH RNG (SEARSTR)	7-25
MKR → LEFT RNG (SEARSTR)	7-25
MKR → RIGHT RNG (SEARSTR)	7-25
Utility	7-26
Utility menu	
Spectrum Analyzer	7-26
MARKER LIST	7-26
MKR LIST on OFF (MKRL ON OFF)	7-26
STATISTICS	7-26
STATISTICS on OFF (MEASTAT ON OFF)	7-26
MARKER TIME	7-26
MKR TIME on OFF (MKRTIME ON OFF)	7-26
NOISE FORM MARKER	7-26
NOISE FORM on OFF (MKRNOI ON OFF)	7-26
Utility menu	
Network Analyzer	7-27
MARKER LIST	7-27
MKR LIST on OFF (MKRL ON OFF)	7-27
STATISTICS	7-27
STATISTICS on OFF (MEASTAT ON OFF)	7-27
MARKER TIME	7-27
MKR TIME on OFF (MKRTIME ON OFF)	7-27
SMITH/POLAR MENU	7-28
SMTH/POLAR MENU	7-28
SMITH CHART	7-28
REAL IMAG (CIRF RI)	7-28
POLAR CHART	7-28
LIN MAG PHASE (CIRF LIN)	7-28
ADMITTANCE CHART	7-28
LOG MAG PHASE (CIRF LOG)	7-28
R+jX (CIRF RX)	7-28
G+jB (CIRF GB)	7-28
SWR PHASE (CIRF SWR)	7-28

8. Instrument State Block

System	8-2
System Menu	
Network Analyzer	
Spectrum Analyzer	8-4
IBASIC	8-4
IBASIC	8-4
MEMORY PARTITION	8-4
MEMORY PARTITION	8-4
CLOCK	8-4
SET CLOCK	8-4
BEEPER	8-4
BEEPER MENU	8-4
LIMIT TESTING	8-4
LIMIT MENU	8-4
SERVICE FUNCTION	8-4
SERVICE MENU	8-4
HP Instrument BASIC Menu	
Network Analyzer	
Spectrum Analyzer	8-5
CONTROL PROGRAM	8-5
Step	8-5
Continue	8-5
Run	8-6
Pause	8-6
Stop	8-6
EDIT PROGRAM	8-6
Edit	8-6
CAT	8-6
SAVE	8-6
RE-SAVE	8-6
GET	8-6
PURGE	8-7
INITIALIZE	8-7
MSI [INTERNAL]	8-7
SCRATCH	8-7
RENumber	8-7
LIST	8-7
COMMAND ENTRY	8-7
COMMAND ENTRY	8-7
CLEAR I/O	8-7
RESET	8-8
Memory Partition Menu	
Network Analyzer	
Spectrum Analyzer	8-9
MEMORY PARTITION	8-9
nn K RAM mmK BASIC	8-9
DONE	8-9

CHANGE YES	8-9
NO	8-9
Clock Menu	
Network Analyzer	
Spectrum Analyzer	8-10
ADJUST TIME	8-10
TIME HH:MM:SS (SETCTIME)	8-10
ADJUST DATE	8-11
DATE MM/DD/YY (SETCDATE)	8-11
DATE FORMAT	8-11
DATE MODE: MonDayYear (MONDYEAR)	8-11
DayMonYear (DAYMYEAR)	8-11
Beeper Menu	
Network Analyzer	
Spectrum Analyzer	8-12
BEEP DONE	8-12
BEEP DONE ON off (BEEPDONE ON OFF)	8-12
BEEP WARNING	8-12
BEEP WARN on OFF (BEEPWARN ON OFF)	8-12
Limit Line Menu	
Network Analyzer	
Spectrum Analyzer	8-13
LIMIT LINE	8-13
LIMIT LINE on OFF (LIMILINE ON OFF)	8-13
LIMIT TESTING	8-13
LIMIT TEST on OFF (LIMITEST ON OFF)	8-13
BEEP FAIL	8-14
BEEP FAIL on OFF (BEEPFAIL ON OFF)	8-14
EDIT LIMIT TABLE	8-14
EDIT LIMIT LINE (EDITLIML)	8-14
SEGMENT	8-14
EDIT (LIMSEDI)	8-14
DELETE (LIMSDEL)	8-14
ADD (LIMSADD)	8-14
CLEAR LIST TABLE	8-15
CLEAR LIST (LIMCLEL)	8-15
DONE (LIMEDONE)	8-15
LIMIT LINE OFFSET	8-15
LIMIT LINE OFFSETS	8-15
SWP PARAM OFFSET (LIMIPRMO)	8-15
AMPLITUDE OFFSET (LIMIAMPO)	8-15
MKR→AMP.OFS. (MKRAMPO)	8-15
Limit Line Entry Menu	
Network Analyzer	
Spectrum Analyzer	8-16
SWP PARAM (LIMPRM)	8-16
MKR→SWP PARAM (MKRSWPRM)	8-16
UPPER LIMIT	8-16
UPPER LIMIT (LIMU)	8-16
LOWER LIMIT	8-16

LOWER LIMIT (LIML)	8-16
DELTA LIMIT	8-17
DELTA LIMIT (LIMD)	8-17
MIDDLE VALUE	8-17
MIDDLE VALUE (LIMM)	8-17
MKR--MIDDLE (MKRMIDD)	8-17
DONE (LIMSDON)	8-17
Local	8-18
Local Menu	
Network Analyzer	
Spectrum Analyzer	8-19
SYSTEM CONTROLLER	8-19
SYSTEM CONTROLLER	8-19
ADDRESSABLE	8-19
ADDRESSABLE ONLY	8-19
HP-IB ADDRESS	8-19
SET ADDRESSES	8-19
ADDRESS:4396	8-19
ADDRESS:CONTROLLER (ADDRCONT)	8-19
Preset	8-20
Copy	8-21
Copy Menu	
Network Analyzer	
Spectrum Analyzer	8-22
PRINT	8-22
PRINT [STANDARD] (PRINALL)	8-22
COPY ABORT	8-22
COPY ABORT (COPA)	8-22
COPY SKEY on OFF (PRSOFT ON OFF)	8-22
TIME STAMP	8-22
COPY TIME on OFF (COPT ON OFF)	8-22
PRINT SETUP	8-22
ORIENT [PORTRAIT] (LANDSCAPE ON OFF)	8-23
FORM FEED ON off (FORMFEED ON OFF)	8-23
LISTING	8-23
LIST VALUES (LISV)	8-23
PARAMETER LIST	8-24
OPERATING PARAMETERS (OPEP)	8-24
CAL KIT LIST	8-24
CAL KIT DEFINITION	8-24
SWEEP TABLE	8-24
LIST SWEEP TABLE	8-24
LIMIT TABLE	8-24
LIMIT TEST TABLE	8-24
Print Setup Menu	
Network Analyzer	
Spectrum Analyzer	8-25
PRINT STANDARD (PRIS)	8-25
COLOR PRINT	8-25
COLOR (PRIC)	8-25

PRINT COLOR [FIXED] (PRICFIXE, PRICVARI) . . .	8-25
DPI (DPI)	8-25
TOP MARGIN (TMARG)	8-25
LEFT MARGIN (LMARG)	8-26
DEFAULT SETUP (DFLT)	8-26
Copy Cal Kit Menu	
Network Analyzer	
Spectrum Analyzer	8-27
STANDARD LIST	8-27
STANDARD DEFINITION (CALC [1-7])	8-27
CLASS LIST	8-27
CLASS ASSIGNMENT (CALCASSI)	8-27
Copy Limit Test Menu	
Network Analyzer	
Spectrum Analyzer	8-28
DISPLAY LIST (DISLLIST)	8-28
DISP MODE: UPR & LWR (DISMAMP UL)	8-28
MID & DLT (DISMAMP MD)	8-28
Copy List Sweep Menu	
Network Analyzer	
Spectrum Analyzer	8-29
LIST TABLE	8-29
DISPLAY LIST (DISL)	8-29
DISP MODE: ST & SP (DISMPRM STSP)	8-29
CTR & SPAN (DISMPRM CTSP)	8-29
Screen Menu	
Network Analyzer	
Spectrum Analyzer	8-30
PRINT	8-30
PRINT [STANDARD] (PRINALL)	8-30
COPY ABORT	8-30
COPY ABORT (COPA)	8-30
TIME STAMP	8-30
COPY TIME on OFF (COPT ON OFF)	8-30
NEXT PAGE (NEXP)	8-30
PREV PAGE (PREP)	8-30
RESTORE DISPLAY (RESD)	8-30
Save	8-31
Save Menu	
Network Analyzer	
Spectrum Analyzer	8-32
SAVE STATE	8-32
STATE (SAVDSTA)	8-32
SAVE DATA	8-32
DATA ONLY	8-32
SAVE BINARY (SAVDDAT)	8-32
DEFINE SAVE DATA	8-32
ASCII SAVE	8-33
SAVE ASCII (SAVDASC)	8-33

DEFINE SAVE DATA	8-33
STOR DEV[] (STODDISK, STODMEMO)	8-33
GRAPHICS (SAVDTIFF)	8-33
4396A STATE (SAVDSTAC)	8-33
OVER WRITE	8-33
RE-SAVE FILE (RESAVD)	8-33
FILE UTILITIES	8-33
PURGE FILE	8-33
PURGE FILE (PURG)	8-33
DIRECTORY	8-34
CREATE DIRECTORY (CRED)	8-34
CHANGE DIRECTORY (CHAD)	8-34
COPY FILE	8-34
COPY FILE (FILC)	8-34
INITIALIZE	8-34
INITIALIZE (INID)	8-34
DISK FORMAT	8-34
FORMAT [] (DISF LIF DOS)	8-34
STORAGE DEVICE	8-34
STOR DEV[] (STODDISK, STODMEMO)	8-34

Define Save Data Menu

Network Analyzer	
Spectrum Analyzer	8-35
RAW on OFF (SAVRAW ON OFF)	8-35
CAL on OFF (SAVCAL ON OFF)	8-35
DATA on OFF (SAVDAT ON OFF)	8-35
MEM on OFF (SAVMEM ON OFF)	8-35
DATA TRACE on OFF (SAVDTRC ON OFF)	8-35
MEM TRACE on OFF (SAVMTRC ON OFF)	8-35

Re-Save File Menu

Network Analyzer	
Spectrum Analyzer	8-36
file name (RESAVED)	8-36
PREV FILES	8-36
NEXT FILES	8-36
STOR DEV[] (STODDISK, STODMEMO)	8-36

Purge File Menu

Network Analyzer	
Spectrum Analyzer	8-37
file name (PURG)	8-37
PREV FILES	8-37
NEXT FILES	8-37
STOR DEV[] (STODDISK, STODMEMO)	8-37

Purge Yes No Menu

Network Analyzer	
Spectrum Analyzer	8-38

PURGE: YES	8-38
NO	8-38
Initialize Yes No Menu	
Network Analyzer	
Spectrum Analyzer	8-39
INITIALIZE DISK: YES	8-39
NO	8-39
Letter Menu	
Network Analyzer	
Spectrum Analyzer	8-40
ENTER CHARACTERS	8-40
SELECT LETTER	8-40
SPACE	8-40
BACK SPACE	8-40
ERASE TITLE	8-40
DONE	8-40
STOR DEV [] (STODDISK, STODMEMO)	8-40
CANCEL	8-40
Recall	8-41
Recall Menu	
Network Analyzer	
Spectrum Analyzer	8-41
file name (RECD)	8-41
PREV FILES	8-41
NEXT FILES	8-41
STOR DEV [] (STODDISK, STODMEMO)	8-41
AUTO RECALL	8-41

9. Accessories and Options

Options Available	9-1
High Stability Frequency Reference (Option 1D5)	9-1
Time-Gated Spectrum Analyzer (Option 1D6)	9-1
50 to 75 Ω Input Impedance Conversion (Option 1D7)	9-1
Impedance Measurement Function (Option 010)	9-1
Keyboard less (Option 1AC)	9-1
Handle Kit (Option 1CN)	9-1
Rack Mount Kit (1CM)	9-2
Rack Mount and Handle Kit (Option 1CP)	9-2
Measurement accessories available	9-2
Test Sets	9-2
HP 85046A/B S Parameter Test Set	9-2
HP 87512A/B Transmission/Reflection Test Set	9-2
Active Probes	9-2
HP 85024A High Frequency Probe (300 kHz to 3 GHz)	9-2
HP 41800A Active Probe (5 Hz to 500 MHz)	9-2
HP 41802A 1 M Ω Input Adapter (5 Hz to 100 MHz)	9-2
HP 54701A Active Probe (DC to 2.5 GHz)	9-2
HP 11945A Close-field Probe Set	9-3
HP 1141A Differential Probe	9-3
Preamplifier	9-3

HP 10855A Broadband Preamplifier (2 MHz to 1300 MHz)	9-3
HP 87405A Preamplifier (10 MHz to 3000 MHz)	9-3
Power Splitters and Directional Bridges	9-3
HP 11850C,D Three-way Power Splitters	9-3
HP 11667A Power Splitter	9-3
HP 86205A/HP 86207A 50 Ω and 75 Ω RF Bridges	9-3
Calibration Kits	9-4
Cables	9-4
HP 11857D 7 mm Test Port Return Cable Set	9-4
HP 11857B 75 Ω Type-N Test Port Return Cable Set	9-4
HP 11851B 50 Ω Type-N RF Cable Set	9-4
Adapters	9-4
HP 11852B 50 Ω to 75 Ω Minimum Loss Pad (DC to 2 GHz)	9-4
Adapter Kits	9-4
System accessories available	9-5
System rack	9-5
Printer	9-5
HP-IB cable	9-5
External Monitors	9-5
Discs	9-5

10. Specifications

Network Measurement	10-1
Source Characteristics	10-1
Frequency Characteristics	10-1
Output Characteristics	10-1
Receiver Characteristics	10-2
Input Characteristics	10-2
Magnitude Characteristics	10-3
Phase Characteristics	10-5
Group Delay Characteristics	10-6
Sweep Characteristics	10-6
Spectrum Measurement	10-7
Frequency Characteristics	10-7
Amplitude Characteristics	10-9
Sweep Characteristics	10-13
Input and Output Characteristics	10-14
Specifications when Option 1D6 Time-Gated spectrum analysis is installed	10-15
Specifications when Option 1D7 50 Ω to 75 Ω Input Impedance Conversion	10-15
HP 4396B Option 010 Specifications	10-16
Measurement Functions	10-16
Display Formats	10-16
Sweep Parameters	10-16
IF Bandwidth	10-16
Calibration	10-16
Unknown Port	10-16
Output Characteristics	10-16
External DC Bias Input	10-17
Measurement Basic Accuracy (Supplemental Performance Characteristics)	10-17
Z - θ Accuracy	10-18

Y - θ Accuracy	10-19
R - X Accuracy (Depands on D)	10-19
G - B Accuracy (Depands on D)	10-19
D Accuracy	10-20
L Accuracy (Depends on D)	10-20
C Accuracy (Depends on D)	10-20
Common to Network and Spectrum Measurement	10-21
Display	10-21
Marker	10-21
Storage	10-21
HP-IB	10-21
Parallel interface	10-21
Probe Power	10-22
Specifications When HP Instrument BASIC Is Operated	10-22
General Characteristics	10-22
Input and Output Characteristics	10-22
Operation Conditions	10-24
Non-operation Conditions	10-24
Others	10-25
Furnished Accessories	10-25

11. System Performance

Typical System Performance	11-1
Introduction	11-1
Comparison of Typical Error-Corrected Measurement Uncertainty	11-1
Reflection Uncertainty of a One-Port Device	11-2
Reflection Uncertainty of a Two-Port Device	11-3
Transmission Uncertainty of a Low-Loss Device	11-4
Transmission Uncertainty of a Wide Dynamic Range Device	11-5
Types of Residual Measurement Errors	11-6
Residual Systematic Errors	11-6
Residual Random Errors	11-6
Residual Drift Errors	11-6
System Error Model	11-7
Reflection Uncertainty Equations	11-8
Total Reflection Magnitude Uncertainty (E_{rm})	11-8
Total Reflection Phase Uncertainty (E_{rp})	11-8
Transmission Uncertainty Equations	11-9
Total Transmission Magnitude Uncertainty (E_{tm})	11-9
Total Transmission Phase Uncertainty (E_{tp})	11-9
Dynamic Accuracy	11-10
Magnitude Dynamic Accuracy	11-10
Determining Relative Magnitude Dynamic Accuracy Error Contribution	11-10
Phase Dynamic Accuracy	11-11
Determining Relative Phase Dynamic Accuracy Error Contribution	11-11
Dynamic Accuracy Error Contribution	11-12
Dynamic Accuracy Error Contribution	11-13
Dynamic Accuracy Error Contribution	11-14
Effects of Temperature Drift	11-15
Temperature Drift with S_{11} One-Port Calibration	11-16
Temperature Drift with Full Two-Port Calibration	11-17

System performance with Different Test Sets and Connector Types	11-18
Determining Expected System performance Procedures	11-25

12. Analyzer Features

System Overview	12-2
Data processing	12-3
Overview	12-3
Data Processing for Network Measurement	12-4
AD converter (ADC)	12-4
Digital Filter	12-4
Frequency characteristics conversion	12-5
Ratio Calculations	12-5
Range Adjustment	12-5
Frequency Characteristics Correction	12-5
Averaging	12-5
Raw Data Arrays	12-5
Calibration Coefficient Arrays	12-5
Data Arrays	12-5
Memory Arrays	12-5
Electrical Delay and Phase Offset	12-6
Conversion	12-6
Format	12-6
Data Hold	12-6
Data Math	12-6
Data Trace Arrays	12-6
Memory Trace Arrays	12-6
Scaling	12-6
Data Processing for Spectrum Measurement	12-7
Decimation Windowing	12-7
Fast Fourier Transform (FFT)	12-8
Absolute Squared	12-8
Video Averaging	12-8
Filter Level Correction	12-8
Video Trigger	12-8
DC Offset Correction	12-8
IF Range Adjustment	12-8
Peak Detector	12-8
Attenuator and IF Range Adjustment	12-8
Averaging	12-8
Frequency Characteristics Level Correction	12-8
Raw Data Arrays	12-8
User Level Correction	12-8
Data Arrays	12-9
Memory Arrays	12-9
Format/Unit conversion	12-9
Data Hold	12-9
Data Math	12-9
Data Trace Array	12-9
Memory Trace Array	12-9
Scaling	12-9
Network Measurement Basics	12-10
S-parameters	12-10
Conversion Function	12-11

Smith Chart	12-12
Polar Chart	12-12
Electrical Delay	12-12
Averaging	12-12
IF Band Reduction	12-13
Group Delay	12-13
Spectrum Measurement Basics	12-16
Detection Modes	12-16
Positive and Negative Peak Modes	12-16
Sample Mode	12-16
Swept Mode and FFT Mode	12-16
Selectivity of the RBW	12-17
Noise measurement	12-18
Noise Format and Marker Noise Form	12-18
Sample Detection Mode for Noise Measurement	12-18
Reference Level Calibration	12-18
Spectrum Monitor at inputs R, A, and B	12-18
Measurement Points and Display Points	12-19
Channel Coupling	12-20
Limit Line Concept	12-21
How Limit Lines are Entered	12-21
Turning Limit Lines Limit Testing On and Off	12-22
Segments Entering Order Needs Notice	12-22
Saving the Limit Line Table	12-23
Offsetting the Sweep Parameter or Amplitude of the Limit Lines	12-23
Supported Display Formats	12-23
Use a Sufficient Number of Points or Errors May Occur	12-23
Displaying, Printing, or Plotting Limit Test Data	12-23
Results of Plotting or Printing the Display with Limit Lines ON	12-23
Gated Sweep	12-24
Trigger Polarity	12-24
Gate Trigger Mode	12-24
Edge Mode	12-25
Level Mode	12-26
RBW Filter Response Time	12-27
Gated Sweep on the Stepped FFT	12-28
Repetitive Sampling	12-29
Markers	12-30
Three Types of Markers	12-30
Marker Value	12-30
Marker Time Mode	12-30
Continuous/Discrete Mode	12-30
Marker on the Data Trace or on the Memory Trace	12-30
Δ Mode	12-31
Marker Search Function	12-31
Width Function	12-31
Peak Definition	12-33
Peak Definition for Network Analyzer	12-33
Peak Definition for Spectrum Analyzer	12-34
HP-IB	12-35
How HP-IB Works	12-35
Talker	12-35
Listener	12-35

Controller	12-36
HP-IB Requirements	12-36
Analyzer HP-IB Capabilities	12-36
Bus Mode	12-37
Setting Addresses	12-38
Calibration for Network Measurement	12-39
Introduction	12-39
Accuracy Enhancement	12-39
Sources of Measurement Errors	12-40
Directivity	12-40
Source Match	12-41
Load Match	12-42
Isolation (Crosstalk)	12-42
Frequency Response (Tracking)	12-43
Correcting for Measurement Errors	12-43
Modifying Calibration Kits	12-44
Definitions	12-44
Define Standard	12-44
Standard Type	12-45
Offset and Delay	12-46
Specify Class	12-46
Accuracy Enhancement Fundamentals-Characterizing	
Systematic Errors	12-48
One-Port Error Model	12-48
Measuring reflection coefficient	12-48
Directivity error	12-48
Source match error	12-49
Frequency response error	12-49
How calibration standards are used to quantify	
these error terms	12-50
Two-Port Error Model	12-53
Measuring Transmission Coefficient	12-53
Load Match Error	12-53
Isolation Errors	12-54
Error Terms the Analyzer Can Reduce	12-54
I/O PORT	12-57
Pin Assignment	12-57
Related HP-IB Commands	12-57

A. Manual Changes

Introduction	A-1
Manual Changes	A-1
Serial Number	A-2
Changes 1	A-2
Changes 2	A-4

B. Softkey Tree	
Measurement Block	B-1
Meas	B-1
Format	B-3
Display	B-4
Scale Ref	B-5
Bw/Avg	B-6
Cal	B-7
Sweep Block	B-10
Center	B-10
Span	B-10
Sweep	B-11
Source	B-12
Trigger	B-13
Marker Block	B-14
Marker	B-14
Marker→	B-15
Search	B-16
Utility	B-18
Instrument State Block	B-19
System	B-19
Local	B-21
Copy	B-22
Save	B-23
Recall	B-24

C. Saving and Recalling Instrument States and Data	
Storage Devices	C-1
Disk Requirements	C-1
Disk Formats	C-1
RAM Disk Memory Capacity	C-2
Copy Files Between the RAM Disk and the Flexible Disk	C-2
File Types And Data Saved	C-2
Binary Files and ASCII Files	C-2
Data Groups	C-2
Instrument States and Internal Data Arrays (STATE)	C-2
Internal Data Arrays (DATA ONLY)	C-2
Graphics image (GRAPHICS)	C-3
File Type and Data Group Combinations	C-3
File Names	C-4
Auto Recall Function	C-4
File Structure	C-5
File Structure of Internal Data Arrays File for Binary Files	C-5
File Header	C-5
Data Group	C-5
File Structure of Internal Data Arrays File for ASCII File	C-9
Status Block and Data Block	C-9
File Structure for Single Channel and Dual Channel	C-11
Data Array Names for the Spectrum Analyzer	C-11
Data Array Names for the Network Analyzer	C-12
Data Groups of the Spectrum Analyzer	C-12
Data Groups of the Network Analyzer	C-12

D. Input Range and Default Settings

Active Channel Block	D-2
Chan 1 and Chan 2	D-2
Measurement Block	D-2
Meas	D-2
Format	D-2
Display	D-3
Scale Ref	D-4
Bw/Avg	D-6
Cal	D-6
Sweep Block	D-7
Sweep	D-7
Source	D-7
Trigger	D-8
Center	D-8
Span	D-8
Start and Stop	D-9
Marker Block	D-9
Marker	D-9
Marker→	D-10
Search	D-10
Utility	D-10
Instrument State Block	D-11
System	D-11
Copy	D-11
Save	D-11
Local	D-12
Results of Power Loss to Battery Backup Memory (Factory Setting)	D-12
Predefined Calibration Kits	D-13
Predefined Standard Class Assignments	D-15

Messages

Error Messages in Alphabetical Order	Messages-1
Error Messages in Numerical Order	Messages-13

Index

Figures

2-1. Analyzer Front Panel	2-1
2-2. Screen Display (Single Channel, Cartesian Format)	2-4
2-3. Analyzer Rear Panel	2-8
3-1. Active Channel Keys	3-1
4-1. Entry Block	4-1
5-1. Softkey Menus Accessed from the Meas Key (for Spectrum Analyzer)	5-3
5-2. Softkey Menus Accessed from the Meas Key (for Network Analyzer)	5-4
5-3. Input Port Menu for Network Analyzer	5-5
5-4. S-parameter Menu for Network Analyzer	5-6
5-5. Input Port Menu for Spectrum Analyzer	5-8
5-6. Analyzer Type Menu	5-9
5-7. Conversion Menu	5-10
5-8. Detection Menu	5-12
5-9. Format Menu for Network Analyzer	5-14
5-10. Format Menu for Spectrum Analyzer	5-16
5-11. Softkey Menus Accessed from the Display Key	5-17
5-12. Display Menu	5-18
5-13. Adjust Display Menu	5-22
5-14. Color Adjust Menu	5-25
5-15. Letter Menu	5-26
5-16. Scale Reference Menu for Network Analyzer	5-27
5-17. Scale Reference Menu for Spectrum Analyzer	5-29
5-18. Bandwidth Menu for Network Analyzer	5-31
5-19. Bandwidth Menu for Spectrum Analyzer	5-33
5-20. Softkey Menus Accessed from the Cal Key for Network Analyzer (1/2)	5-35
5-21. Softkey Menus Accessed from the Cal Key for Network Analyzer (2/2)	5-36
5-22. Calibration Menu	5-37
5-23. Response Standard Menu	5-43
5-24. Response and Isolation Menu	5-45
5-25. S11 1-Port Menu	5-46
5-26. S22 1-Port Menu	5-47
5-27. Full 2-Port Cal Menu	5-48
5-28. One-Path 2-Port Cal Menu	5-52
5-29. Reference Plane Menu	5-55
5-30. Modify Cal Kit Menu	5-56
5-31. Specify Offset Menu	5-61
5-32. Standard Type Menu	5-62
5-33. Calibration Menu for Spectrum Analyzer	5-65
6-1. Softkey Menus Accessed from the Sweep Key	6-2
6-2. Sweep Menu for Network Analyzer	6-3
6-3. Sweep Menu for Spectrum Analyzer	6-6
6-4. Clear List Menu	6-10

6-5. Segment Menu for Network Analyzer	6-11
6-6. Segment Menu for Spectrum Analyzer	6-13
6-7. Source Menu for Network Analyzer	6-15
6-8. Source Menu for Spectrum Analyzer	6-17
6-9. Trigger Menu	6-18
6-10. Center Menu	6-22
6-11. Span Menu	6-24
7-1. Softkey Menus Accessed from the Marker Key	7-2
7-2. Marker Menu	7-3
7-3. Delta Mode Menu	7-5
7-4. Sub-Marker Menu	7-7
7-5. Clear Sub-Marker Menu	7-8
7-6. Marker→ Menu	7-10
7-7. Softkey Menus Accessed from the Search Key for the Network Analyzer	7-12
7-8. Softkey Menus Accessed from the Search Key for the Spectrum Analyzer	7-13
7-9. Search Menu for the Network Analyzer	7-14
7-10. Search Menu for the Spectrum Analyzer	7-14
7-11. Peak Menu	7-18
7-12. Target Menu	7-19
7-13. Widths Menu	7-20
7-14. Peak Definition Menu for Network Analyzer	7-22
7-15. Peak Definition Menu for Spectrum Analyzer	7-24
7-16. Search Range Menu	7-25
7-17. Utility Menu for Spectrum Analyzer	7-26
7-18. Utility Menu for Network Analyzer	7-27
8-1. Softkey Menus Accessed from the System Key	8-3
8-2. System Menu	8-4
8-3. IBASIC Menu	8-5
8-4. Memory Partition Menu	8-9
8-5. Clock Menu	8-10
8-6. Beeper Menu	8-12
8-7. Limit Line Menu	8-13
8-8. Limit Line Entry Menu	8-16
8-9. Local Menu	8-19
8-10. Softkey Menus Accessed from the Copy key	8-21
8-11. Copy Menu	8-22
8-12. Print Setup Menu	8-25
8-13. Copy Cal Kit Menu	8-27
8-14. Copy Limit Test Menu	8-28
8-15. Copy List Sweep Menu	8-29
8-16. Screen Menu	8-30
8-17. Softkey Menus Accessed from the Save Key	8-31
8-18. Save Menu	8-32
8-19. Define Save Data Menu	8-35
8-20. Re-save file menu	8-36
8-21. Purge File Menu	8-37
8-22. Purge Yes No Menu	8-38
8-23. Initialize Yes No Menu	8-39
8-24. Letter Menu for Save Key	8-40
8-25. Recall Menu	8-41
10-1. Magnitude Dynamic Accuracy	10-4
10-2. Phase Dynamic Accuracy	10-5
10-3. Typical Group Delay Accuracy	10-6

10-4. Typical Noise Sidebands (with option 1D5)	10-8
10-5. Typical On-screen Dynamic Range	10-9
10-6. Typical Dynamic Range at S input	10-10
10-7. Typical Dynamic Range at R, A, and B inputs	10-10
10-8. Typical Displayed Average Noise Level	10-11
10-9. Impedance Measurement Accuracy	10-18
10-10. I/O Port Pin Assignments	10-22
10-11. Trigger Signal	10-23
10-12. S-Parameter Test Set Interface Pin Assignments	10-24
11-1. Total Reflection Magnitude Uncertainty of One-Port Device	11-2
11-2. Total Reflection Phase Uncertainty of One-Port Device	11-2
11-3. Total Reflections Magnitude Uncertainty of Two-Port Device	11-3
11-4. Total Reflection Phase Uncertainty of Two-Port Device	11-3
11-5. Total Transmission Magnitude Uncertainty of a Low-Loss Device	11-4
11-6. Total Transmission Phase Uncertainty of a Low-Loss Device	11-4
11-7. Total Transmission Magnitude Uncertainty of a Wide Dynamic Range Device	11-5
11-8. Total Transmission Phase Uncertainty of a Wide Dynamic Range Device	11-5
11-9. HP 4396B/85046A System Error Model	11-7
11-10. Typical Magnitude Dynamic Accuracy Error (@Reference Power Level=Full Scale)	11-12
11-11. Typical Phase Dynamic Accuracy Error (@Reference Power Level=Full Scale)	11-12
11-12. Typical Magnitude Dynamic Accuracy Error (@Reference Power Level=-20 dB from Full Scale)	11-13
11-13. Typical Phase Dynamic Accuracy Error (@Reference Power Level=-20 dB from Full Scale)	11-13
11-14. Typical Magnitude Dynamic Accuracy Error (@Reference Power Level=-60 dB from Full Scale)	11-14
11-15. Typical Phase Dynamic Accuracy Error (@Reference Power Level=-60 dB from Full Scale)	11-14
11-16. Total Reflection Magnitude Uncertainty (@One-Port Cal)	11-16
11-17. Total Reflection Phase Uncertainty (@One-Port Cal)	11-16
11-18. Total Transmission Magnitude Uncertainty (@Full Two-Port Cal)	11-17
11-19. Total Transmission Phase Uncertainty (@Full Two-Port Cal)	11-17
12-1. Analyzer Simplified Block Diagram	12-2
12-2. Data Processing for Network Measurement	12-4
12-3. Data Processing for Spectrum Measurement	12-7
12-4. S-Parameters of a Two-Port Device	12-10
12-5. Reflection Impedance and Admittance Conversions	12-11
12-6. Transmission Impedance and Admittance Conversions	12-11
12-7. Constant Group Delay	12-13
12-8. Higher Order Phase Shift	12-14
12-9. Rate of Phase Change Versus Frequency	12-14
12-10. Variations in Frequency Aperture	12-15
12-11. Swept Mode and Stepped FFT Mode	12-17
12-12. Resolving Small Adjacent Signal	12-17
12-13. Measurement Points and Display Points	12-19

12-14. The Concept of Segments as a Point between Two Sets of Limit Lines	12-21
12-15. Edge Mode	12-25
12-16. Level Mode	12-26
12-17. RBW Filter Response Time	12-27
12-18. Repetitive Sampling	12-29
12-19. Bandwidth Search Example	12-32
12-20. Peak Definition for Network Analyzer	12-33
12-21. Peak Definition for Spectrum Analyzer	12-34
12-22. Analyzer Single Bus Concept	12-37
12-23. Directivity	12-40
12-24. Source Match	12-41
12-25. Load Match	12-42
12-26. Sources of Error in a Reflection Measurement	12-48
12-27. Reflection Coefficient	12-48
12-28. Effective Directivity E_{DF}	12-49
12-29. Source Match E_{SF}	12-49
12-30. Reflection Tracking E_{RF}	12-49
12-31. "Perfect Load" Termination	12-50
12-32. Measured Effective Directivity	12-51
12-33. Short Circuit Termination	12-51
12-34. Open Circuit Termination	12-52
12-35. Measured S_{11}	12-52
12-36. Major Sources of Error	12-53
12-37. Transmission Coefficient	12-53
12-38. Load Match E_{LF}	12-54
12-39. Isolation E_{XF}	12-54
12-40. Full Two-Port Error Model	12-55
12-41. I/O Port Pin Assignments	12-57
A-1. Serial Number Plate	A-2
B-1. Softkey Menus Accessed from the Meas Key for Spectrum Analyzer	B-1
B-2. Softkey Menus Accessed from the Meas Key for Network Analyzer	B-2
B-3. Softkey Menus Accessed from the Format Key for Spectrum Analyzer	B-3
B-4. Softkey Menus Accessed from the Format Key for Network Analyzer	B-3
B-5. Softkey Menus Accessed from the Display Key	B-4
B-6. Softkey Menus Accessed from the Scale Ref Key for Network Analyzer	B-5
B-7. Softkey Menus Accessed from the Format Key for Spectrum Analyzer	B-5
B-8. Softkey Menus Accessed from the Bw/Avg Key for Network Analyzer	B-6
B-9. Softkey Menus Accessed from the Bw/Avg Key for Spectrum Analyzer	B-6
B-10. Softkey Menus Accessed from the Cal Key for Network Analyzer (1/2)	B-7
B-11. Softkey Menus Accessed from the Cal Key for Network Analyzer (2/2)	B-8
B-12. Softkey Menus Accessed from the Cal Key for Spectrum Analyzer	B-9
B-13. Softkey Menus Accessed from the Center Key	B-10
B-14. Softkey Menus Accessed from the Span Key	B-10

B-15. Softkey Menus Accessed from the Sweep Key	B-11
B-16. Softkey Menus Accessed from the Source Key for Network Analyzer	B-12
B-17. Softkey Menus Accessed from the Source Key for Spectrum Analyzer	B-12
B-18. Softkey Menus Accessed from the Trigger Key	B-13
B-19. Softkey Menus Accessed from the Marker Key	B-14
B-20. Softkey Menus Accessed from the Marker→ Key	B-15
B-21. Softkey Menus Accessed from the Search Key for the Network Analyzer	B-16
B-22. Softkey Menus Accessed from the Search Key for the Spectrum Analyzer	B-17
B-23. Softkey Menus Accessed from the Utility Key for Spectrum Analyzer	B-18
B-24. Softkey Menus Accessed from the Utility Key for Network Analyzer	B-18
B-25. Softkey Menus Accessed from the System Key	B-20
B-26. Softkey Menus Accessed from the Local Key	B-21
B-27. Softkey Menus Accessed from the Copy key	B-22
B-28. Softkey Menus Accessed from the Save Key	B-23
B-29. Softkey Menus Accessed from the Recall Key	B-24
C-1. File Header Structure	C-5
C-2. RAW Data Group Structure for the Network Analyzer	C-6
C-3. RAW Data Group Structure for the Spectrum Analyzer	C-6
C-4. CAL Data Group Structure for the Network Analyzer	C-7
C-5. CAL Data Group Structure for the Spectrum Analyzer	C-7
C-6. <i>DATA, MEMORY, DATA TRACE</i> and <i>MEMORY TRACE</i> Data Group Structure	C-8

Tables

8-1. List Value Format	8-23
9-1. Supported Printers and Printing Modes	9-5
11-1. Parameters of System error Model	11-7
11-2. Typical System Performance for Devices with 7 mm Connectors HP 4396B with HP 85046A Test Set (300 kHz to 1.8 GHz)	11-19
11-3. Typical System Performance for Devices with 3.5 mm Connectors HP 4396B with HP 85046A Test Set (300 kHz to 1.8 GHz)	11-20
11-4. Typical System Performance for Devices with 50 Ω Type-N Connectors HP 4396B with HP 85046A or 85044A Test Set (300 kHz to 1.8 GHz)	11-21
11-5. Typical System Performance for Devices with 75 Ω Type-N Connectors HP 4396B with HP 85046B or 85044B Test Set (300 kHz to 1.8 GHz)	11-22
11-6. Typical System Performance for Devices with 50 Ω Type-N Connectors HP 4396B with HP 87512A Test Set (100 kHz to 1.8 GHz)	11-23
11-7. Typical System Performance for Devices with 75 Ω Type-N Connectors HP 4396B with HP 87512B Test Set (100 kHz to 1.8 GHz)	11-24
11-8. Reflection Measurement Uncertainty Worksheet	11-26
11-9. Transmission Measurement Uncertainty Worksheet	11-27
12-1. Minimum Gate Length on the Stepped FFT mode	12-28
12-2. Standard Definitions	12-45
12-3. Standard Class Assignments Table	12-46
A-1. Manual Changes by Serial Number	A-1
A-2. Manual Changes by Firmware Version	A-1
C-1. Valid Characters for File Names	C-4
C-2. Suffixes and Extensions Added Automatically	C-4
C-3. Contents of ASCII Files	C-10
C-4. Data Groups and Data Array Names for Spectrum Analyzer	C-11
C-5. Data Groups and Data Array Names for the Network Analyzer Mode	C-12
C-6. Network Measurement Type Versus Raw Data Saved	C-13
C-7. Calibration Type for Network Measurement Versus CAL Data Saved	C-13
D-1. 3.5 mm Standard Cal Kit	D-13
D-2. 7 mm Standard Cal Kit	D-13

D-3. 50 Ω Type-N Standard Cal Kit	D-13
D-4. 75 Ω Type-N Standard Cal Kit	D-14
D-5. Standard Class Assignments Table (7 mm and 3.5 mm)	D-15
D-6. Standard Class Assignments Table (50 Ω Type-N) . . .	D-15
D-7. Standard Class Assignments Table (75 Ω Type-N) . . .	D-16

Introduction

This chapter provides an overview of the main features of the analyzer. These features include the front and rear panels and the six key blocks. The front and rear panel section provides information on the input/output connectors, the LCD, and other panel features. The six key block sections describe the keys and their associated menus and how they function together.

Analyzer's Features

The following paragraphs describe the analyzer's features. Individual chapters describe each block of controls in more detail.

Front and Rear Panel

Analyzer functions are activated from the front panel by using front panel hardkeys or softkeys. Measurement results are displayed on the LCD (which also displays the measurement conditions and the instrument status). The front panel has input and output ports to connect to the device under test (DUT) or test signal source and a flexible disk drive to store data and instrument status.

The rear panel has input and output connectors to control the analyzer from an external device or to control external devices from the analyzer.

For more information, see Chapter 2.

ACTIVE CHANNEL Block

The Analyzer has two digital channels for independent measurement and display of data. This block has two keys that select the active channel. Once an active channel is selected, you can control it using the front panel keys and display its trace and data annotations. If you want to change the active channel, you must select the new channel before you make any other changes.

For more information, see Chapter 3.

ENTRY Block

This block provides the numerical and units keypad, the knob, and the step keys. These controls are used in combination with other keys to enter or change numeric data.

For more information, see Chapter 4.

MEASUREMENT Block

This block controls the measurement and display functions. Each key provides access to softkey menus. Because measurement functions are different for network and spectrum measurements, the menus displayed by pressing a key in this block are different for each mode of operation (except for the **Display** key).

Note



When you press **Meas**, the analyzer displays the **ANALYZER TYPE** softkey for the selected mode of operation (either network or spectrum analyzer mode). If you want to change the mode of operation, press **ANALYZER TYPE** softkey.

For more information, see Chapter 5.

Network Analyzer Mode

Meas Provides access to a series of menus used to select the analyzer type and the parameters or input ports to be measured. **Format** Displays the menu used to select the display format of the data. Various rectangular and polar formats are available for display of magnitude, phase, impedance, group delay, real data, imaginary data, and standing wave ratio (SWR).

Display Provides access to a series of menus used for instrument state and active channel display functions. These menus include dual channel display (overlaid or split), definition of the displayed active channel trace in terms of the mathematical relationship between data and trace memory, display intensity, color selection, active channel display title, and frequency blanking.

Scale Ref Displays the menu used to modify the vertical axis scale and the reference line value as well as the electrical length and phase offset.

Bw/Avg Provides access to three different noise reduction techniques: sweep-to-sweep averaging, group delay aperture, and variable IF bandwidth.

Cal Provides access to a series of menus that implement the accuracy enhancement procedures.

Spectrum Analyzer Mode

Meas Provides access to a series of menus used to select the analyzer type, input ports to be measured, and the detection modes.

Format Displays the menu used to select the display units.

Display Provides access to a series of menus used for instrument and active channel display functions. These menus include dual channel display (overlaid or split), definition of the displayed active channel

trace in terms of the mathematical relationship between data and trace memory, display intensity, color selection, active channel display title, and frequency blanking.

Scale Ref Displays the menu used to modify the vertical axis scale and the maximum mixer level, and to control the input attenuator.

Bw/Avg Provides access to three different noise reduction techniques: sweep-to-sweep averaging, video bandwidth, and variable resolution bandwidth.

Cal Displays the menu used for level calibration.

SWEEP Block This block defines the range to sweep, the control trigger function, and the source RF OUT signal.

Sweep Provides access to a series of menus used for selecting the sweep type, editing the list sweep table, specifying the number of points to be displayed, and modifying the sweep time.

Source Displays the menu used to control the RF OUT signal.

Trigger Provides access to a series of menus used for selecting trigger mode and trigger source.

Start, **Stop**, **Center**, and **Span** Used to specify sweep range.

For more information, see Chapter 6.

MARKER Block This block displays the marker on the screen and controls the marker function.

Marker Displays the marker and provides access to a series of menus used for selecting the marker mode and displaying the sub-markers and the Δ marker.

Marker→ Provides access to a series of menus used for changing selected measurement parameters to the current marker value.

Search Displays menus used for searching the trace for a specific amplitude-related point and placing the marker on that point.

Utility Displays a menu used for listing all marker values, calculating and displaying statistics values of the display trace, and indicating the time elapsed since the sweep started.

For more information, see Chapter 7.

INSTRUMENT STATE Block

This block provides control of channel-independent system functions. These include the controller modes, real-time clock, limit line and limit testing, HP Instrument BASIC, printing, saving instrument states and trace data to a built-in disk or memory.

System Provides access to a series of menus used for programming HP Instrument BASIC, controlling the real-time clock and the beeper, defining the limit line table, and performing limit line testing.

Local Returns front panel control to the user from an external controller and displays a series of menus used to select the HP-IB mode and modify the HP-IB addresses.

Preset Sets the analyzer to the preset state. See Appendix D, for a listing of the preset values.

Copy Provides access to the menus used for controlling external printers and defining the print parameters.

Save Provides access to the menus used for saving the instrument state and data to the flexible disk or RAM disk memory.

Recall Displays the menu used to recall the contents of disk files or memory back into the analyzer.

For more information, see Chapter 8.

Front and Rear Panel

This chapter describes the features of the front and rear panels of the analyzer. It provides illustrations and descriptions of the front panel features, the LCD display and its labels, and the rear panel features and connectors.

Front Panel

Analyzer functions are activated from the front panel (Figure 2-1) by using the front panel hardkeys or softkeys. In this manual, all front panel hardkeys and softkey labels are shown as **Hardkey** and **Softkey**, respectively.

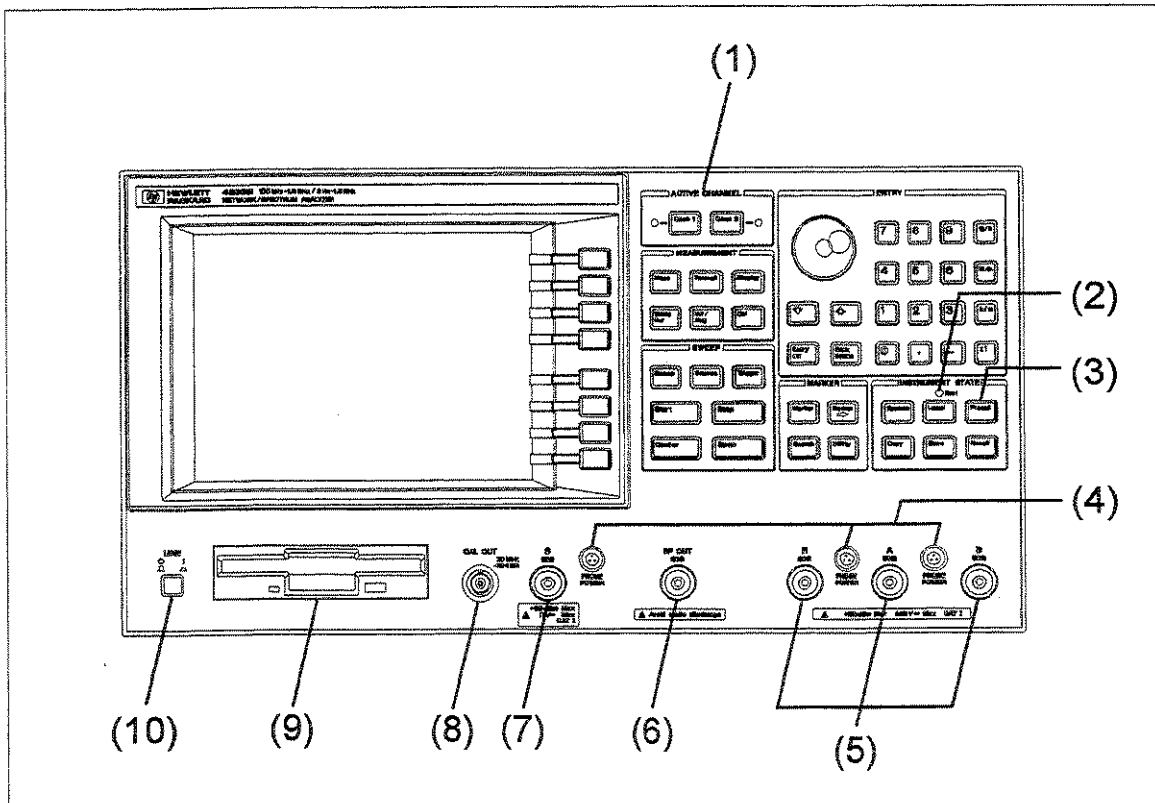

CB002001

Figure 2-1. Analyzer Front Panel

1. Front Panel Keys and Softkeys

Some of the front panel keys change instrument functions directly, and others provide access to additional functions available in softkey menus. Softkey menus are lists of up to eight related functions that can be displayed in the softkey label area at the right-hand side of the display. The eight keys to the right of the LCD are the softkeys. Pressing one of the softkeys selects the adjacent menu function. This either executes the labeled function and makes it the active function, causes instrument status information to be displayed, or presents another softkey menu. Some of the analyzer's menus are accessed directly from front panel keys and some from other menus. For example, the sweep menu accessed by pressing the **Sweep** key presents all the sweep functions such as sweep type, number of points, and sweep time. Pressing **NUMBER OF POINTS** allows the required number of points displayed per sweep to be entered directly from the number pad. **RETURN** softkeys return to previous menus. **DONE** indicates completion of a specific procedure and then returns to an earlier menu.

Usually, when a menu changes, the present active function is cleared.

Softkeys that are Joined by Vertical Lines

When several possible choices are available for a function, the softkeys are joined by vertical lines. For example, in the spectrum input port menu under the **Meas** key, the available inputs are listed: **S, R, A, B** with a vertical line between them. Note that only one softkey can be selected at a time. When a selection has been made from the listed alternatives, that selection is underlined until another selection is made.

Softkeys That Toggle On or Off

Some softkey functions can be toggled ON or OFF, for example averaging. This is indicated in the softkey label. The current state, ON or OFF, is capitalized in the softkey label.

Example:

AVERAGING ON off The word on is capitalized, showing that averaging is currently on.
AVERAGING on OFF The word off is capitalized, showing that averaging is currently off.

Softkeys that Show Status Indications in Brackets

Some softkey labels show the current status of a function in brackets. These include simple toggle functions and status-only indicators. An example of a toggled function is the **PRINT [STANDARD]** or **PRINT [COLOR]** softkey. The **DATA MATH[]** softkey is an example of a status-only indicator, where the selected equation of the data math function is shown in brackets in the softkey label.

2. HP-IB "REMOTE" Indicator

This lights when the analyzer is in the remote state.

3.  This key returns the instrument to a known standard preset state from any step of any manual procedure. A complete listing of the instrument preset conditions is provided in Appendix D.

4. PROBE POWER Connector

This connector (fused inside the instrument) supplies power to an active probe for in-circuit measurements of AC circuits. Applicable active probes are described in Chapter 9.

5. Network Analyzer Inputs R, A, and B

In the network analyzer mode, these inputs receive signals from a test set, source, or device under test (DUT). The R input is used as the reference input. The input impedance of each input is 50 Ω . In the spectrum analyzer mode, these inputs can monitor the spectrum of the input signals.

INSTALLATION CATEGORY I

Note



Do not exceed the operating input power, voltage, and current level and signal type appropriate for the instrument being used, refer to your instrument's operation manual.

Note



Electrostatic discharge(ESD) can damage the highly sensitive microcircuits in your instrument. ESD damage is most likely to occur as the test fixtures are being connected or disconnected. Protect them from ESD damage by wearing a grounding strap that provides a high resistance path to ground. Alternatively, ground yourself to discharge any static charge built-up by touching the outer shell of any grounded instrument chassis before touching the test port connectors.

6. RF OUT Connector

Connects the RF output signal from the analyzer's internal source to a test set or power splitter. The output impedance at this connector is 50 Ω . When the spectrum analyzer mode is selected, the RF output is automatically turned off. If RF output signal is to be used for the spectrum analyzer, you must turn it on. The frequency of the output signal is equal to the frequency at the spectrum measurement point and tracks the sweep frequency of the spectrum analyzer.



7. Spectrum Analyzer Input S

This input receives the signal for the spectrum analyzer mode. The input impedance is 50 Ω .

INSTALLATION CATEGORY I

8. CAL OUT Connector

This connector provides a calibration signal of 20 MHz at -20 dBm.

9. Built-in Flexible Disk Drive

Stores the measurement data, instrument status, list sweep tables, and HP Instrument BASIC programs. The applicable disk formats are LIF (logical interchange format) and DOS (disk operating system) format.

10. LINE Switch Switches the power supply of HP 4396B ON or OFF.

Screen display

Displays a grid on which the measurement data is plotted, the currently selected measurement traces, and other information describing the measurement. Figure 2-2 shows the locations of the different information labels.

In addition to the full-screen display shown in Figure 2-2, a split display is available (see "Display" in Chapter 5). In this case, information labels are provided for each half of the display.

The screen can also be used as the HP Instrument BASIC display. HP Instrument BASIC uses either a full-screen display or a half-screen display below the graticule display as a text screen.

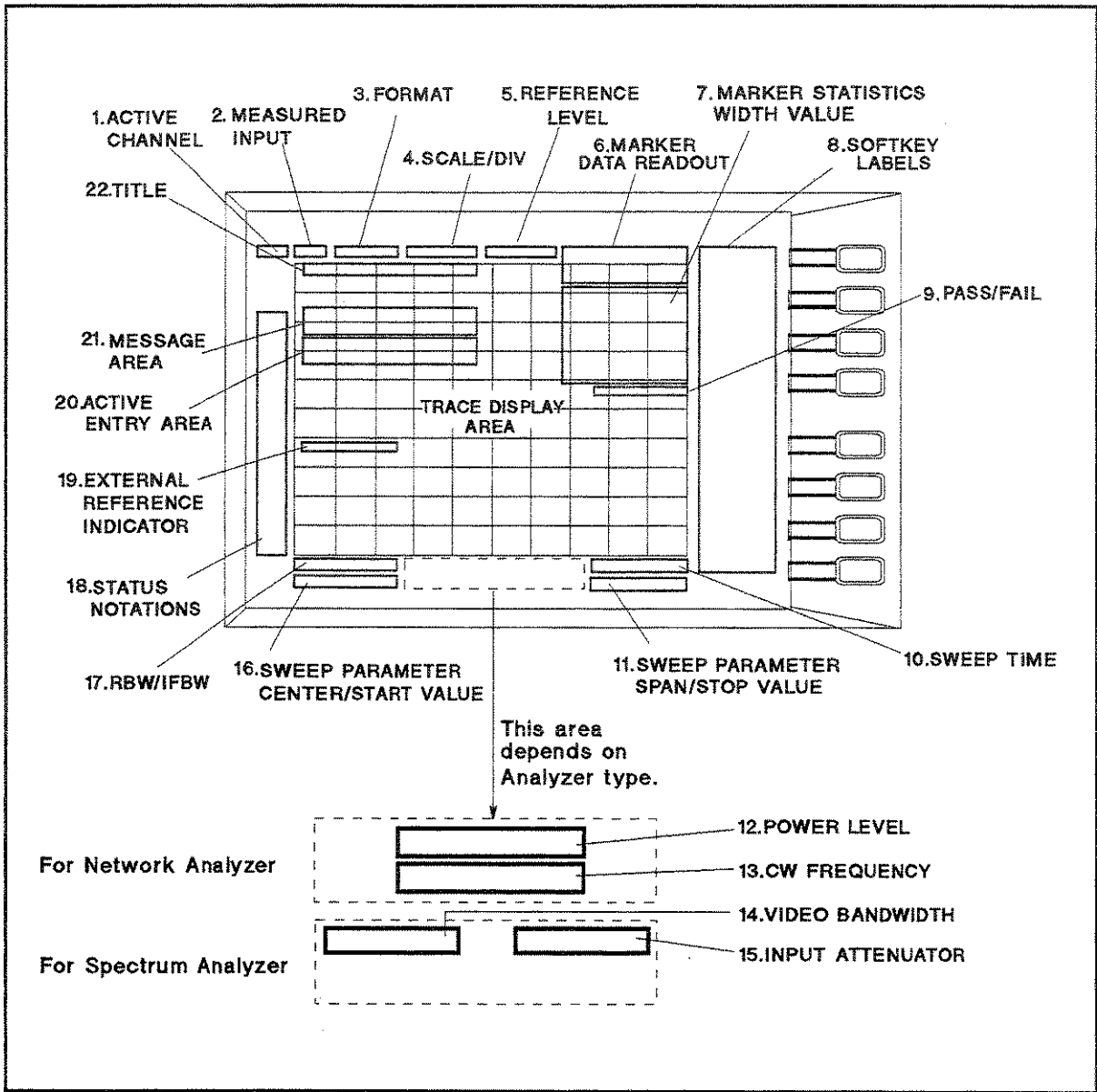

Figure 2-2. Screen Display (Single Channel, Cartesian Format)

1. Active Channel

Displays the number of the current active channel (selected with the keys in the active channel block). If dual channel is ON with an overlaid display, both channel 1 and channel 2 appear in this area.

2. Measured Input(s) Shows the input, S-parameter, or ratio of inputs currently measured (as selected using the **Meas** key).

3. Format This is the display format selected using the **Format** key.

4. Scale/Div Displays the scale selected by the **Scale Ref** key in units appropriate to the current measurement.

5. Reference Level Displays the value of a reference line in Cartesian formats or the outer circle in polar formats. It is selected using the **Scale Ref** key. However, the reference line is invisible (it is indicated by a small triangle adjacent to the graticule at the left). The position of the reference line for the spectrum analyzer is fixed at the top of the Cartesian format.

6. Marker Data Readout

Displays the values of the marker in units appropriate to the current measurement (see Chapter 7). The status of the marker is also displayed under the marker values. The following status notations are used:

Cpl	Marker couple is tuned on. (When single channel is displayed, this notation is not displayed even if the marker couple is on.)
Xch	Cross channel is turned on.
Sgnl	Signal tracking is turned on. (When both signal tracking and search tracking are turned on, only Sgnl is displayed because search tracking is not allowed in this case.)
Peak	PEAK search tracking is turned on.
Max	MAX search tracking is turned on.
Min	MIN search tracking is turned on.
Targ	TARGET search tracking is turned on.
PksA	PEAK ALL search tracking is turned on.
PksL	PEAK LEFT ALL search tracking is turned on.
PksR	PEAK RIGHT ALL search tracking is turned on.

7. Marker Statistics and Width Value

Displays the statistical marker values determined by using the menus accessed with the **Utility** key, and the width value determined by using the menus accessed with the **Search** key. See Chapter 7.

8. Softkey Labels Displays the menu labels that define the function of the softkeys immediately to the right of the label.

9. Pass/Fail Indicates the values used for limit testing using limit lines. See "Limit Line Concept" in Chapter 12.

- 10. Sweep Time** Displays the sweep time. When sweep time is manually changed, # is displayed between SWP and the sweep time value.
- 11. Sweep Parameter Span/Stop Value**
Displays the stop frequency of the sweep range in frequency domain measurements or the upper limit of a power sweep (only in the network analyzer mode). When the sweep parameter is in center/span mode, the span is shown in this space. The sweep parameter values can be blanked (see "Display" in Chapter 5).
- 12. Power Level** Displays the power level of RF output when the sweep parameter is frequency. This is network analyzer mode only. When the power sweep is selected, this area is blank.
- 13. CW Frequency** Displays the measurement frequency when the power sweep is selected (network analyzer mode only). When the frequency sweep is selected, this area is blank.
- 14. Video Bandwidth (VBW)**
Displays the video bandwidth (spectrum analyzer mode only).
- 15. Input Attenuator** Displays the input attenuator value at the input S (spectrum analyzer mode only).
- 16. Sweep Parameter Center/Start Value**
Displays the start frequency of the sweep range in frequency domain measurements or the lower power value in power sweep (network analyzer mode only). When the sweep parameter is in center/span mode, the center stimulus value is shown in this space.
(For power sweep measurements, the CW frequency is displayed centered between the start and stop power values.)
- 17. RBW/IFBW** Displays the RBW (in spectrum analyzer mode) or IFBW (in network analyzer mode). When RBW is manually changed, # is displayed between RBW and RBW value. Because IFBW does not have auto mode, # is not displayed when IFBW is changed.

18. Status Notations

Displays the current status of various functions for the active channel. The following notations are used:

*	Sweep parameters changed: measured data in doubt until a complete fresh sweep has been taken.
P↓	RF output is OFF (only for the network analyzer).
P	RF output is ON (spectrum analyzer mode only).
P?	RF output level is set over the maximum value of range. This notation is displayed when the power slope is turned on and the total output power level of the power slope value and the RF output level are over the maximum output level.
Slp	Power slope is ON (network analyzer mode only).
Cor	Error correction is ON (network analyzer mode only). Level correction is ON (spectrum analyzer mode only).
C2	Two-port error correction is ON (network analyzer mode only).
C?	Sweep parameters have changed and interpolated error correction is ON (network analyzer mode only).
C2?	Sweep parameters have changed and interpolated two-port correction is ON (network analyzer mode only).
C!	Sweep parameters have changed and interpolated error correction is NOT available (network analyzer mode only).
C2!	Sweep parameters have changed and interpolated two-port correction is NOT available (network analyzer mode only).
Del	Electrical delay, port extension, or phase offset has been added or subtracted (network analyzer mode only).
Neg	Negative peak detection is ON (spectrum analyzer mode only).
Smp	Sample detection is ON (spectrum analyzer mode only).
Avg	Sweep-by-sweep averaging is ON. The averaging count is shown below.
Max	Maximum hold is ON.
Min	Minimum hold is ON.
G*	Data math Gain is ON.
-0	Data math Offset is ON.
G&0	Data math Gain and Offset are ON.
D-M	Data math (Data Trace - Memory Trace) is ON.
D+M	Data math (Data Trace + Memory Trace) is ON.
D/M	Data math (Data Trace / Memory Trace) is ON.
Hld	Hold sweep.
↑	Fast sweep indicator.
Ext	Waiting for external trigger (BNC in rear panel).
Man	Waiting for manual trigger.
Bus	Waiting for HP-IB trigger.
Svc	A service mode is turned on. If this notation is shown, the measurement data will be out of specifications. (See <i>Performance Test Manual</i> .)

Note



No status notation is displayed when Gate trigger and Video trigger are used.

19. External Reference

ExtRef is displayed when an external reference signal is connected to the external reference input on the rear panel (even if phase is not locked).

- 20. **Active Entry Area** Displays the active function and its current value.
- 21. **Message Area** Displays prompts or error messages. See "Error Messages" for more information on error messages.
- 22. **Title** Displays a descriptive alpha-numeric string title defined by you and entered as described in "Display" in Chapter 5.

Rear Panel Features and Connectors

Figure 2-3 shows the features and connectors on the rear panel. Requirements for the input signals to the rear panel connectors are provided in Chapter 10.

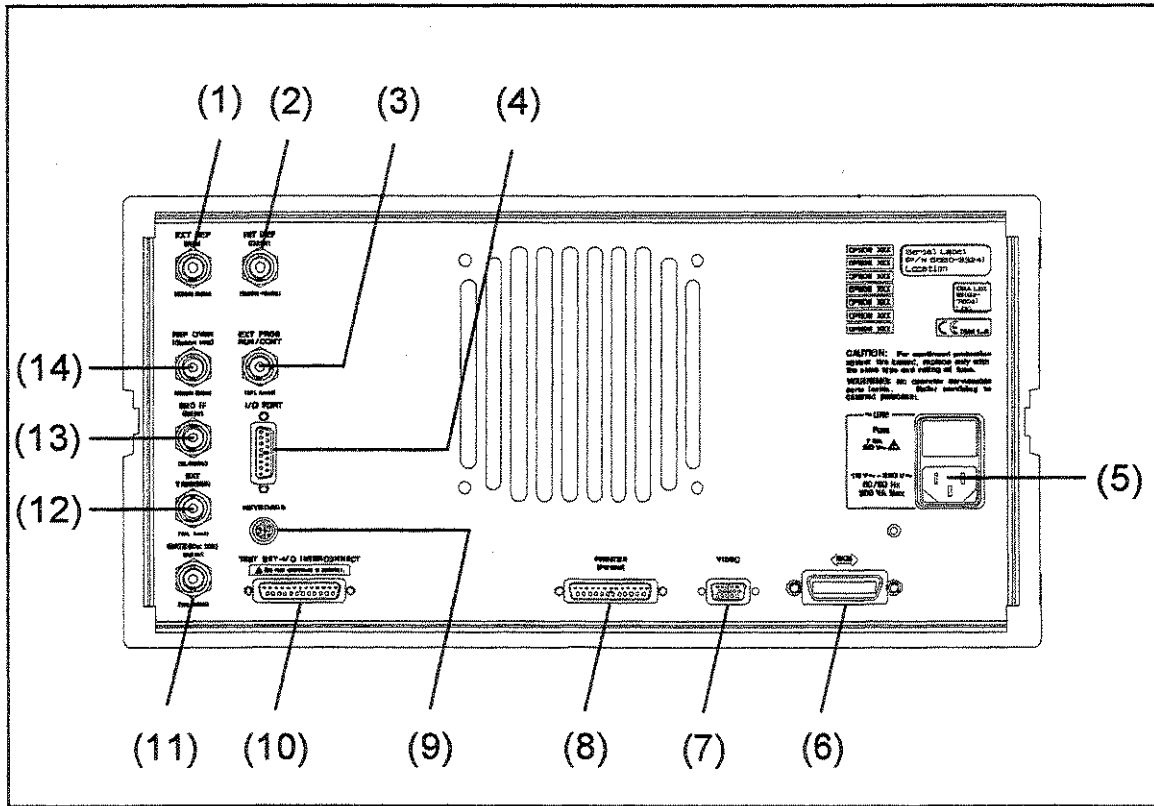

GB002002

Figure 2-3. Analyzer Rear Panel

1. External Reference Input

Connects an external frequency reference signal to the analyzer that is used to phase lock the analyzer for increased frequency accuracy.

When the analyzer is equipped with the external oven (Option 1D5), this connector must be connected to REF OVEN connector. The external frequency reference function is automatically enabled when a signal is connected to this input. When the signal is removed, the analyzer automatically switches back to its internal frequency reference.

2. Internal Reference Output

Connects to the frequency reference input of an external instrument to phase lock it to the analyzer.

3. External Program RUN/CONT Input

Externally triggers RUN or CONT of the HP Instrument BASIC program. The positive edge of a pulse more than 20 μ s wide in the LOW state triggers RUN or CONT. The signal is TTL-compatible.

4. I/O Port

Connects to external devices such as a handler on a production line. See "I/O PORT" in Chapter 12 for additional information.

5. Power

This is input for the main power cable. Insert the main-power cable plug only into a socket outlet that has a protective ground contact.

6. HP-IB Interface

Connects the analyzer to an external controller and other instruments in an automated system. This connector is also used when the analyzer itself is the controller of compatible peripherals. See "HP-IB" in Chapter 12.

7. External Monitor Terminal

This terminal outputs measurement results to an external color monitor. Color monitors supporting VGA (scan speed of 31.5 kHz) can be connected to this terminal.

8. Parallel Interface

This interface enables the output of displayed results to a printer. It complies with the Centronics parallel interface standard. See "Printer" in Chapter 9 for supported printers.

9. mini DIN Keyboard Connector

Connect a mini DIN keyboard to this connector usually when using Instrument BASIC.

Note



Keyboards that are not specified may operate incorrectly. Be sure to use the specified PS/2, 101 English keyboard.

10. Test Set I/O Interface

This interface enables the connection between the analyzer and the test set using the cable included in the S-parameter test set package. The connection allows users to control the test set from the analyzer. See Chapter 9 for the test set that can be connected. This interface is not used for the transmission/reflection test kit.

Caution



If a printer is connected to this interface by mistake, it may be damaged. Do not connect a printer to this interface.

11. Gate Output (Option 1D6 Only)

Outputs a signal that indicates the status of the gate when in the EDGE mode of the gate trigger. The signal is TTL-compatible. High indicates gate ON, low indicates gate OFF.

12. External Trigger Input

Triggers a measurement sweep. The positive (or negative) edge of a pulse more than 20 μ s wide in the LOW (or HIGH) state starts a measurement. The signal is TTL-compatible. To use this connector, set the trigger mode to external using softkey functions (see “Trigger” in Chapter 6).

13. 2nd IF Output

Outputs the 2nd IF signal that is the down-converted signal of the input of the analyzer. The frequency of IF signal is 21.42 MHz.

14. Reference Oven Output (Option 1D5 Only)

Connects to the EXT REF INPUT connector when Option 1D5 is installed. Option 1D5 improves the frequency accuracy and stability of the analyzer.

Active Channel Block

The analyzer has two active channels (Figure 3-1) that provide independent measurement and display of data. Two different sets of data can be measured simultaneously (for example, a spectrum and network measurement or one measurement with two different frequency spans). The data can be displayed separately or simultaneously.

The HP-IB programming command is shown in parenthesis following the key or softkey.

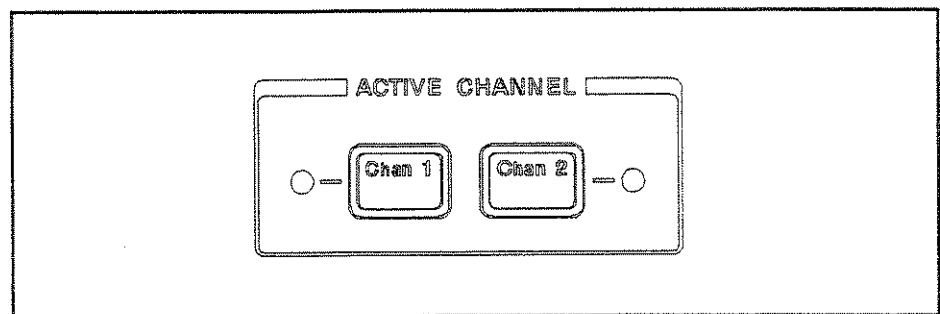

09003001

Figure 3-1. Active Channel Keys

Chan 1 (CHAN1) and Chan 2 (CHAN2)

The **Chan 1** and **Chan 2** keys select which channel is the *active channel*. This is the channel currently controlled by the front panel keys. The active channel trace and data annotations are displayed on the display. All the channel specific functions that are selected apply to the active channel. The current active channel is indicated by an amber LED adjacent to the corresponding channel key.

The analyzer has dual trace capability, so that both the active and inactive channel traces can be displayed, either overlaid or on separate graticules (split display). The dual channel and split display features are available in the display menus.

Coupling Channels

When both channels are in the network analyzer mode, the sweep parameter values can be coupled or uncoupled between the two channels (independent of the dual channel and split display functions). See "Channel Coupling" in Chapter 12 for a listing of the sweep parameter that are coupled in the channel couple mode.

Another coupling capability is coupled markers. When both channels are in the network analyzer mode, measurement markers can have the same stimulus values for the two channels or they can be uncoupled for independent control in each channel. See Chapter 7 for more information about markers.

When either or both channels are in the spectrum analyzer mode, the sweep parameter values and the markers cannot be coupled.

Entry Block

The ENTRY block (Figure 4-1) contains the numeric and unit's keypad, the knob, and the step keys. These controls are used in combination with other front panel keys and softkeys to modify the active entry, to enter or change numeric data, and to change the value of the marker. In most cases, the keypad, knob, and step keys can be used interchangeably.

Before a function can be modified, it must be made the active function by pressing a front panel key or softkey. It can then be modified directly with the knob, the step keys, or the digits' keys and a terminator.

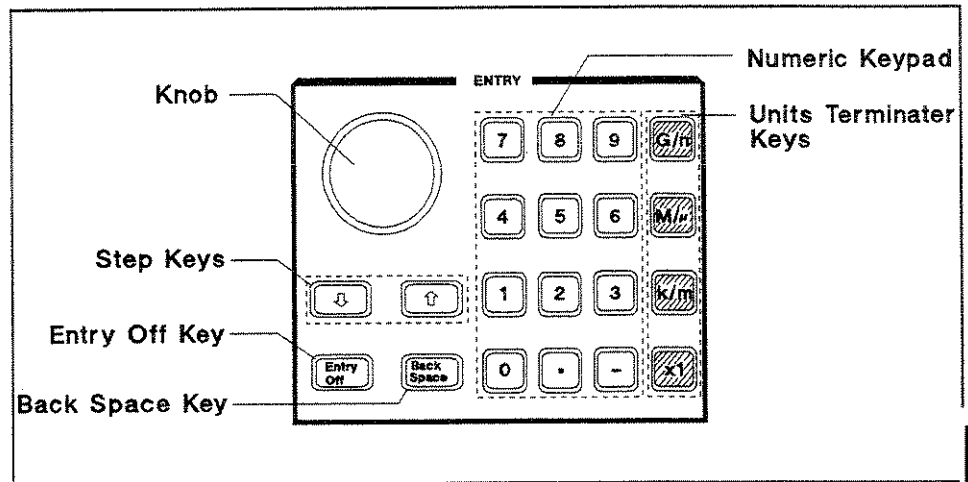

Figure 4-1. Entry Block

Numeric Keypad

The numeric keypad selects digits, decimal point, and minus sign for numerical entries. A unit's terminator is required to complete the entry.

Terminator Keys

The unit's terminator keys are the four keys in the right-hand column of the keypad. These specify units of numerical entries from the keypad and also terminate the entries. A numerical entry is incomplete until a terminator is entered. When a terminator is required, the data entry arrow "←" points at the last entered digit in the active entry area. When the unit's terminator key is pressed, the arrow is replaced by the units selected. The units are abbreviated on the terminator keys as follows:

$\overline{G/n}$ (G, N, KEY 35)	Giga/nano ($10^9 / 10^{-9}$)
$\overline{M/\mu}$ (MA, U, KEY 34)	Mega/micro ($10^6 / 10^{-6}$)
$\overline{k/m}$ (K, M, KEY 33)	kilo/milli ($10^3 / 10^{-3}$)
$\overline{x1}$ (KEY 32)	basic units: dB, dBm, degrees, seconds, Hz, or dB/GHz (may be used to terminate unitless entries such as averaging factor). No HP-IB commands are required.

Knob

The knob adjusts the current values continuously for functions such as scale, reference level, and others. If a marker is on, and no other function is active, the knob can adjust the marker position. Values changed by the knob are effective immediately and require no terminator.

\uparrow and \downarrow

The \downarrow (KEY 16) and \uparrow (KEY 17) keys step the current value of the active function up or down. Except for the CENTER value, the steps are predetermined and cannot be altered. The CENTER step size can be entered in the CENTER menu under $\overline{\text{Center}}$. No unit's terminator is required with these two keys.

Entry Off (KEY 18)

Clears and turns off the active entry area and any displayed prompts, error messages, or warnings. Use **Entry Off** to clear the display before plotting. This key also prevents active values from being changed by accidentally moving the knob. The next function selected turns the active entry area back on.

Back Space (KEY 19)

Deletes the last entry (or the last digit entered from the numeric keypad).

Measurement Block

The measurement block keys and associated menus provide control of analyzer type, measurement parameter, input port, display, resolution or IF bandwidth, averaging, and calibration. The following list shows the functions controlled by each key in the measurement block.

- Meas**
 - Selecting analyzer type (network and spectrum analyzer)
 - Selecting input port
 - Selecting S-parameter to be measured (network analyzer only)
 - Converting measurement data to equivalent impedance or admittance (network analyzer only)
 - Multiplying phase (network analyzer only)
 - Selecting detection mode (spectrum analyzer only)
- Format**
 - Selecting display format
 - Measuring noise form (spectrum analyzer only)
 - Selecting measurement unit (spectrum analyzer only)
- Display**
 - Selecting display trace (data and memory)
 - Storing data trace to memory trace
 - Holding maximum or minimum value
 - Selecting display mode
 - Dual/Single channel
 - Split/Override
 - Allocating screen between analyzer and HP Instrument BASIC. (option 1C2 only)
 - Performing trace math
 - Displaying titles
 - Erase frequency display
 - Adjusting display color and intensity
- Scale Ref**
 - Scaling trace
 - Controlling group delay and phase offset (network analyzer only)
 - Controlling input attenuator (spectrum analyzer only)
- Bw/Avg**
 - Selecting value of RBW or IFBW
 - Setting group delay aperture (network analyzer only)
 - Controlling averaging function
 - Controlling video bandwidth (spectrum analyzer only)
- Cal**
 - Performing calibration measurement (network analyzer only)
 - Defining standard kits for Calibration (network analyzer only)
 - Performing level calibration (spectrum analyzer only)

The HP-IB programming command is shown in parenthesis following the key or softkey. Characters following the program code that are separated by a space are parameters of the command.

For example:

- ON|OFF shows that either ON or OFF can be used as a parameter. COUC ON|OFF means COUC ON or COUC OFF.
- [1-7] shows that numerical 1, 2, 3, 4, 5, 6, and 7 can be used as a parameter. SMKR [1-7] ON means SMKR 1 ON, SMKR 2 ON, SMKR 3 ON, SMKR 4 ON, SMKR 5 ON, SMKR 6 ON, and SMKR 7 ON.

For more information on HP-IB commands, see the *HP 4396B HP-IB Command Reference*.

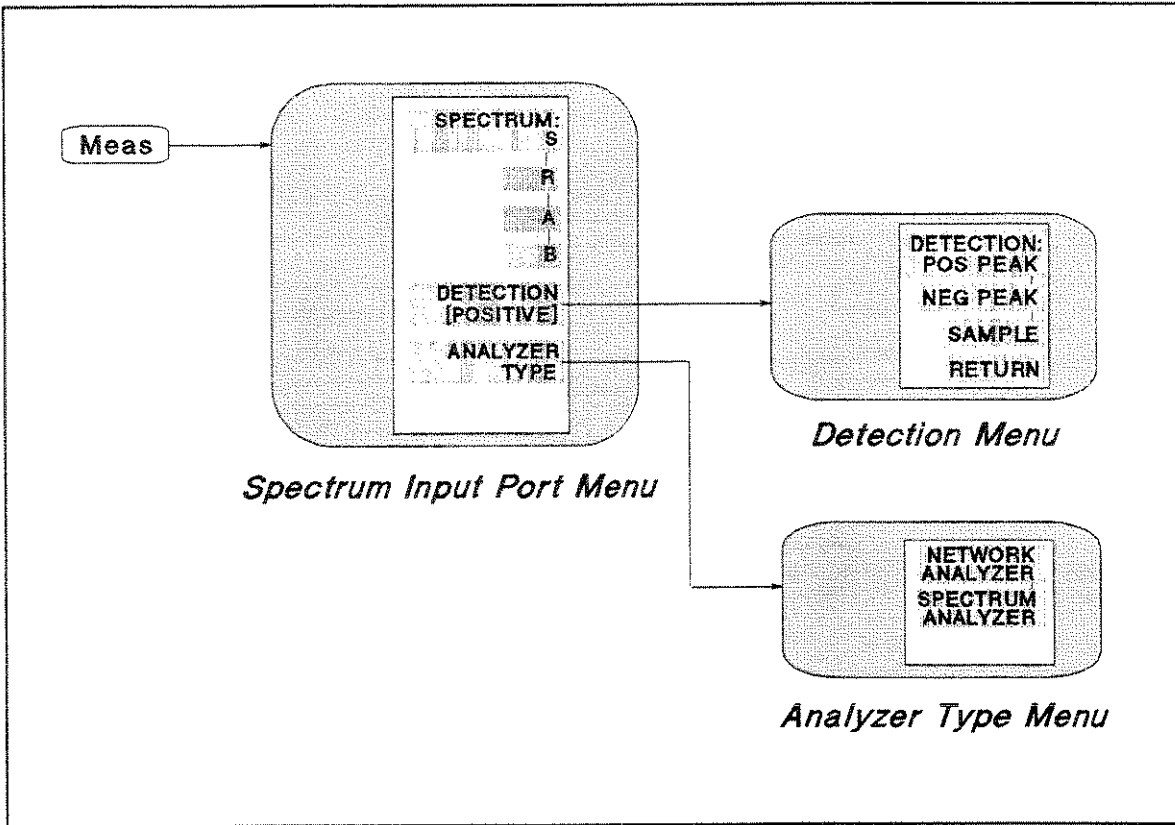

C5006034

Figure 5-1. Softkey Menus Accessed from the Meas Key (for Spectrum Analyzer)

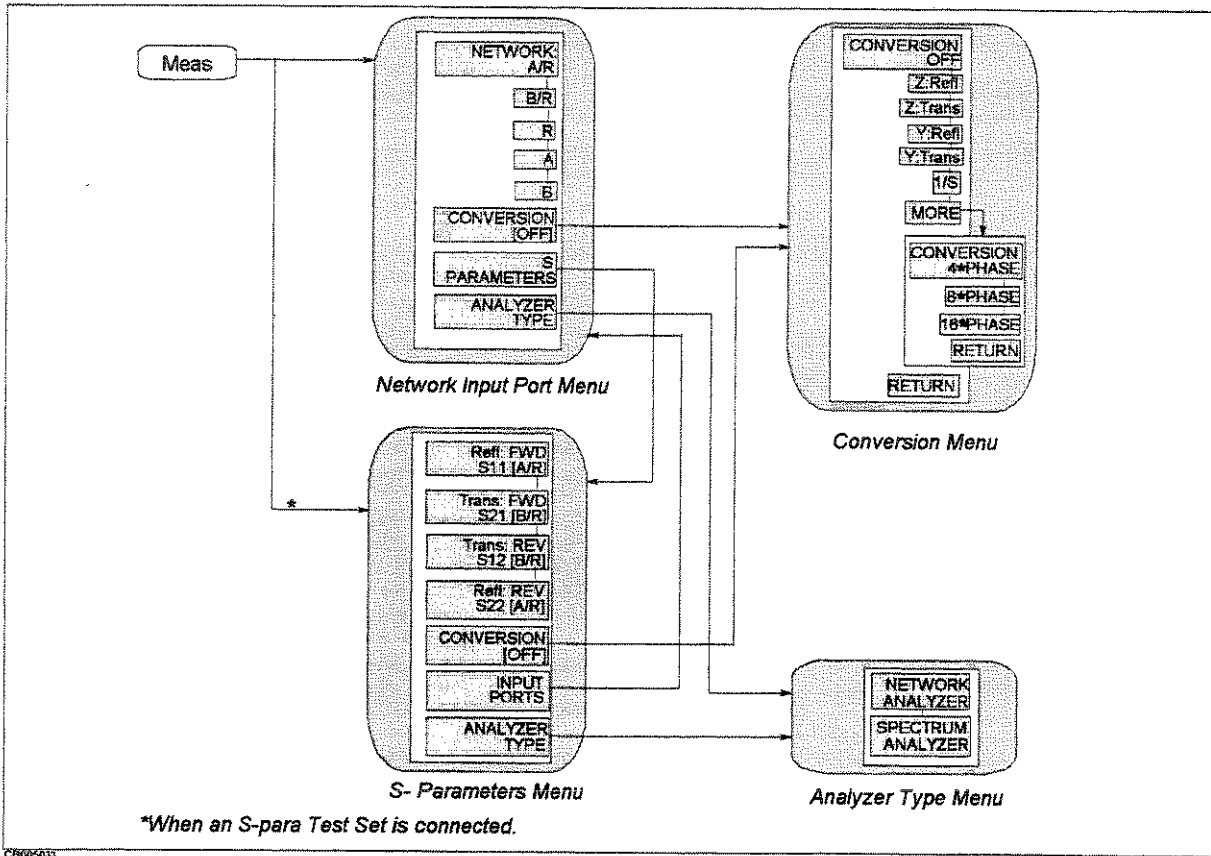

Figure 5-2. Softkey Menus Accessed from the **Meas** Key (for Network Analyzer)

Input port menu

Network Analyzer

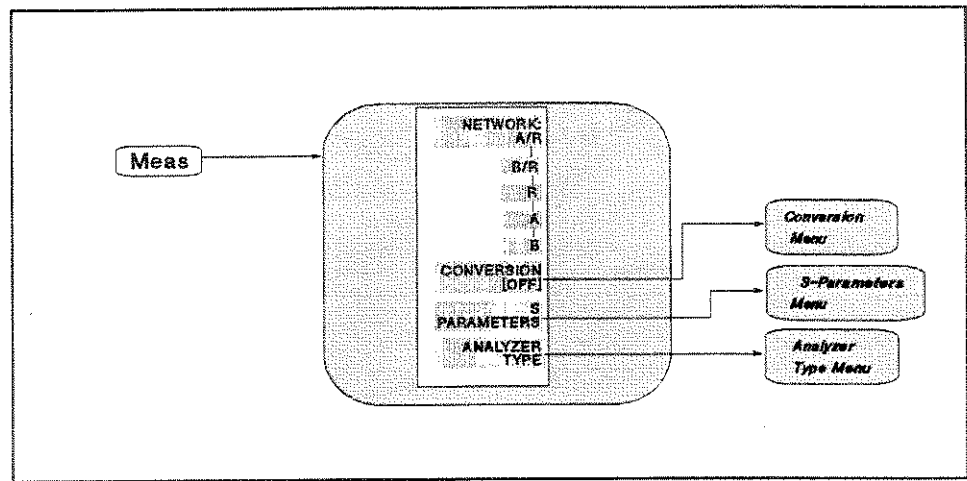

Figure 5-3. Input Port Menu for Network Analyzer

NETWORK MEASUREMENT

NETWORK: A/R (MEAS AR)

Calculates and displays the complex ratio of the signal at input A to the reference signal at input R.

B/R (MEAS BR)

Calculates and displays the complex ratio of input B to input R.

R (MEAS R)

Measures the absolute power amplitude at input R.

A (MEAS A)

Measures the absolute power amplitude at input A.

B (MEAS B)

Measures the absolute power amplitude at input B.

CONVERSION [OFF]

Displays the *conversion menu* that converts the measured data to impedance (Z) or admittance (Y). When a conversion parameter has been defined, it is shown in brackets under the softkey label. If no conversion has been defined, **OFF** is shown in brackets.

S-PARAMETERS

Displays the *S-parameter menu* that defines the input ports and test set direction for S-parameter measurements.

ANALYZER TYPE

Displays the *analyzer type menu* that selects the network or spectrum analyzer mode of operation.

S-parameter menu

Network Analyzer

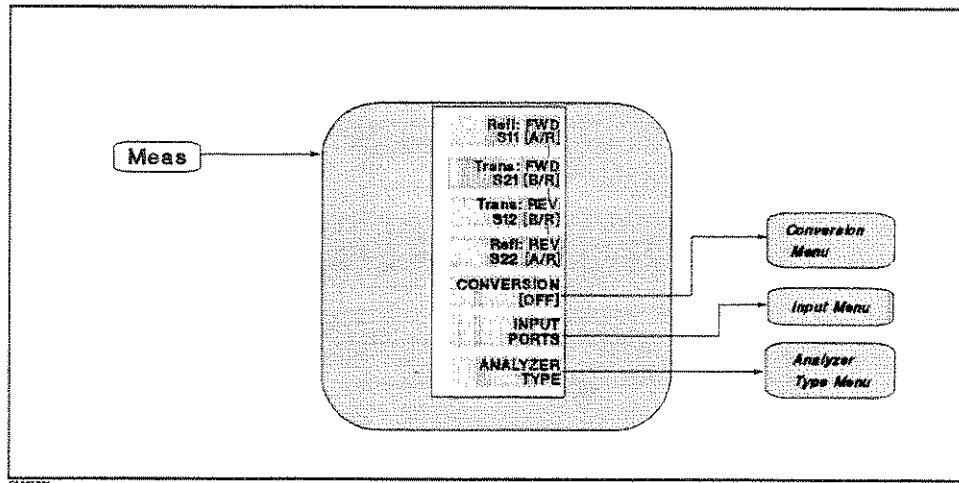

Figure 5-4. S-parameter Menu for Network Analyzer

S-PARAMETER MEASUREMENT

Ref1: FWD S11 [A/R] (MEAS S11)

Configures the S-parameter test set to measure S_{11} (the complex reflection coefficient, magnitude and phase, of the DUT input).

Trans:FWD S21 [B/R] (MEAS S21)

Configures the S-parameter test set for measurement of S_{21} (the complex forward transmission coefficient, magnitude and phase, of the DUT).

Trans:REV S12 [B/R] (MEAS S12)

Configures the S-parameter test set to measure S_{12} (the complex reverse transmission coefficient, magnitude and phase, of the DUT).

Ref1: REV S22 [A/R] (MEAS S22)

Defines the measurement as S_{22} (the complex reflection coefficient, magnitude, and phase, of the output of the DUT)

CONVERSION []

Displays the *conversion menu* that converts the measured data to impedance (Z) or admittance (Y), or multiplies phase data. When a conversion parameter has been defined, it is shown in brackets under the softkey label. If no conversion has been defined, the softkey label reads **CONVERSION [OFF]**.

INPUT PORTS

Displays the *input ports menu* that is used to define a ratio or single-input measurement rather than an S-parameter measurement.

ANALYZER TYPE

Displays the *analyzer type menu* that selects the network or spectrum analyzer mode of operation.

Meas

Input port menu Spectrum Analyzer

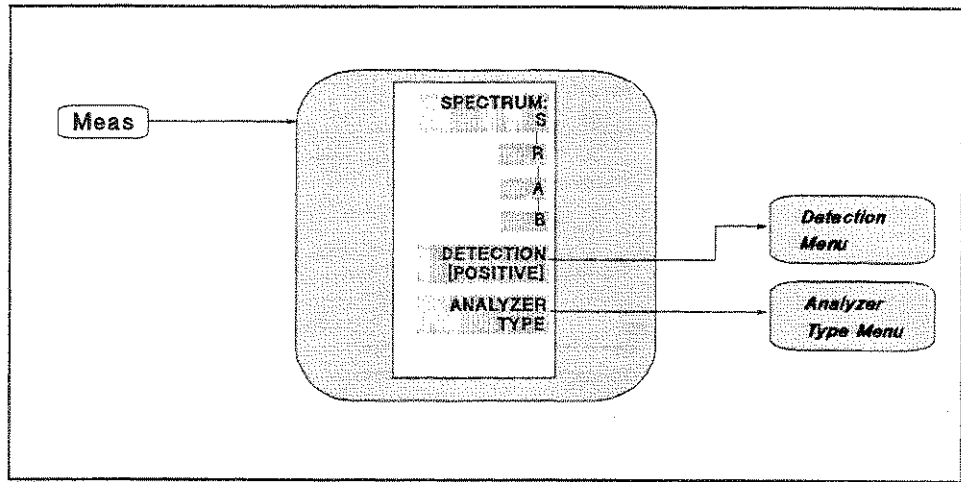

Figure 5-5. Input Port Menu for Spectrum Analyzer

INPUT PORTS **SPECTRUM: S** (MEAS S)

Measures the spectrum at input S.

R (MEAS R)

Measures the spectrum at input R.

A (MEAS A)

Measures the spectrum at input A.

B (MEAS B)

Measures the spectrum at input B.

DETECTION []

Displays the *detection menu* that is used to select the type of detection mode (positive, negative, or sample mode). The detection mode defined is shown in brackets under the softkey label.

ANALYZER TYPE

Displays the *analyzer type menu* that selects the network or spectrum analyzer mode of operation.

Analyzer type menu

Network Analyzer
Spectrum Analyzer

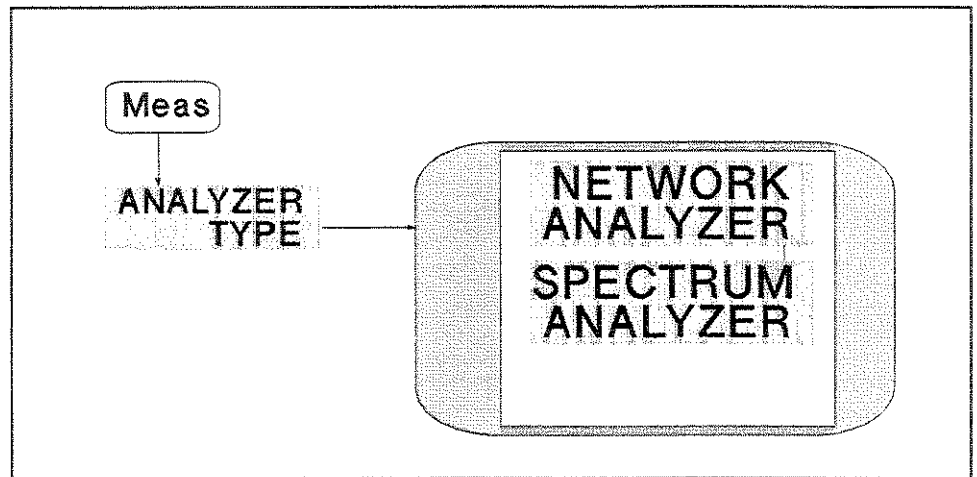

Figure 5-6. Analyzer Type Menu

NETWORK ANALYZER

NETWORK ANALYZER (NA)

Selects the network analyzer mode as the analyzer type. When the analyzer type is changed, all parameters of the active channel are preset.

SPECTRUM ANALYZER

SPECTRUM ANALYZER (SA)

Selects the spectrum analyzer mode as the analyzer type. When the analyzer type is changed, all parameters of the active channel are preset.

Conversion menu

Network Analyzer

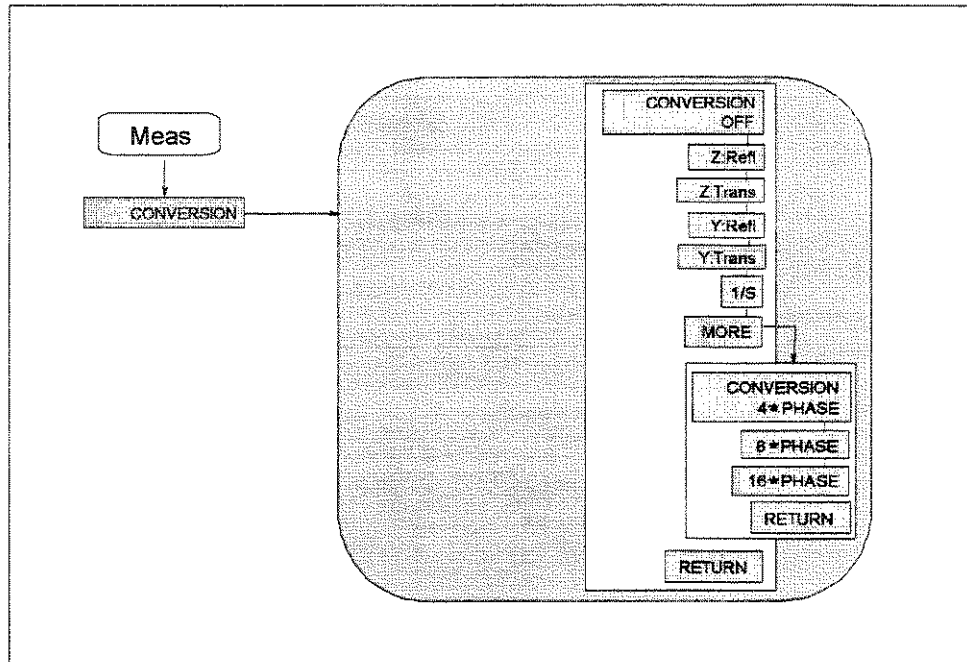

Figure 5-7. Conversion Menu

OFF (CONV OFF)

Turns off all parameter conversion operations.

IMPEDANCE

Z:Refl (CONV ZREF)

Converts reflection data to its equivalent impedance values.

Z:Trans (CONV ZTRA)

Converts transmission data to its equivalent impedance values.

ADMITTANCE

Y:Refl (CONV YREF)

Converts reflection data to its equivalent admittance values.

Y:Trans (CONV YTRA)

Converts transmission data to its equivalent admittance values.

See "Conversion Function" in Chapter 12 for more information on the equivalent impedance and admittance.

1/S (CONV ONEDS)

Expresses the data in inverse S-parameter values.

MULTIPLE PHASE

4xPHASE (CONV MP4)

Multiplies phase data by a factor of 4.

8xPHASE (CONV MP8)

Multiplies phase data by a factor of 8.

16xPHASE (CONV MP16)

Multiplies phase data by a factor of 16.

Note

For more information on the conversion function, see “Conversion Function” in Chapter 12.

Detection menu

Spectrum Analyzer

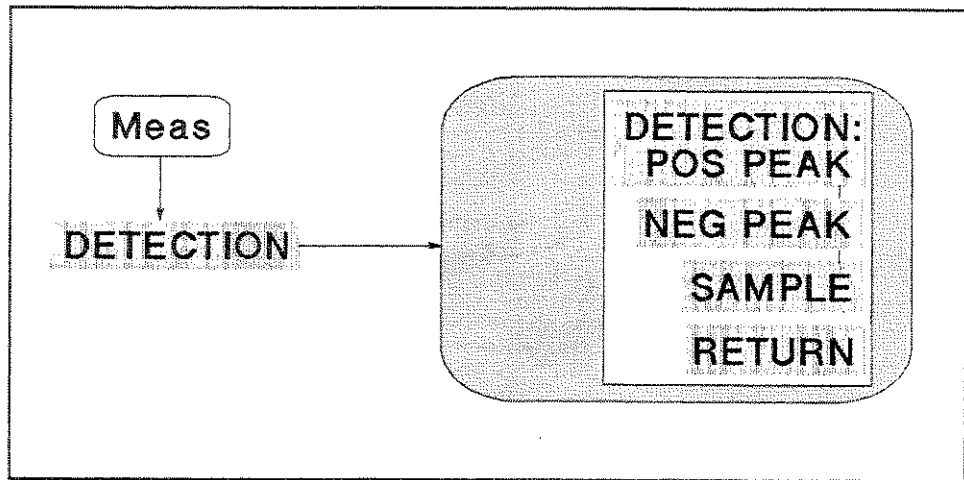

Figure 5-8. Detection Menu

POSITIVE PEAK	POS PEAK (DET POS)	Selects positive peak mode as the detection technique for displaying trace information.
NEGATIVE PEAK	NEG PEAK (DET NEG)	Selects negative peak mode for detection technique.
SAMPLE	SAMPLE (DET SAM)	Selects sample mode for detection technique.

Note



For more information on detection techniques, see "Detection Modes" in Chapter 12.

Format

Displays the format menu that is used to select the appropriate display format for the measured data and to select the appropriate measurement unit for the spectrum measurement data. For network measurements, various rectangular and polar formats are available to display magnitude, phase, real data, imaginary data, impedance, group delay, and SWR. The units of network measurement are automatically changed to correspond to the displayed format. For spectrum measurements, spectrum and noise formats are available. The various units of spectrum measurement are available to display spectrum and noise, dBm, dBV, dB μ V, Watt, and Volt. The units of spectrum measurement can also be selected using the softkey menu accessed from **Format** key.

Format

Format menu
Network Analyzer

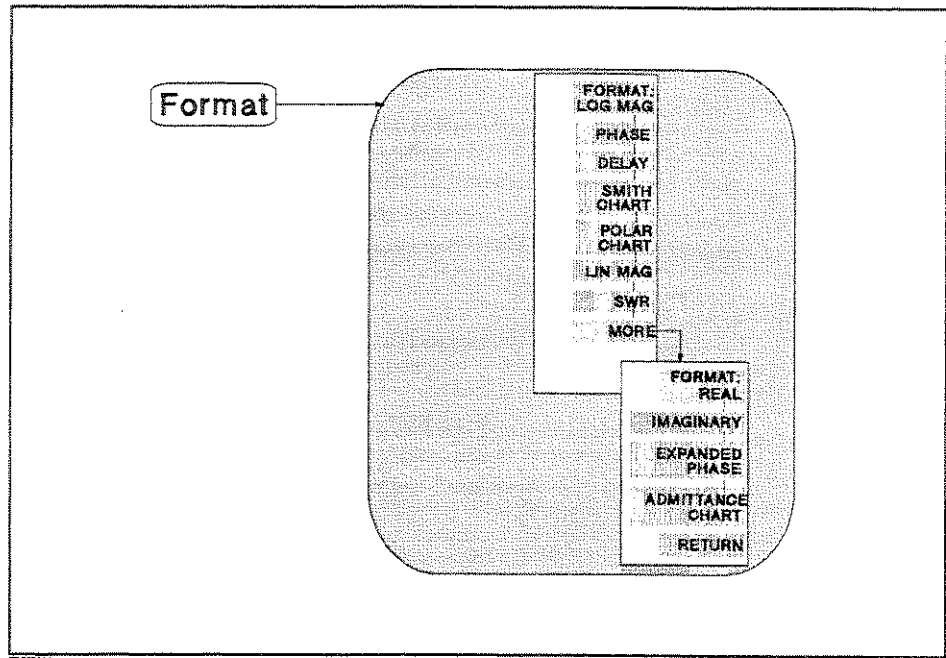

0306005

Figure 5-9. Format Menu for Network Analyzer

- LOG MAGNITUDE **FORMAT: LOG MAG** (FMT LOGM)
Displays the log magnitude format.
- PHASE **PHASE** (FMT PHAS)
Displays a Cartesian format of the phase portion of the data (measured in degrees). This format displays the phase shift versus frequency.
- GROUP DELAY **DELAY** (FMT DELA)
Selects the group delay format. Activated markers give values in seconds.
- SMITH CHART **SMITH [Re Im]** (FMT SMITH)
Displays a Smith chart format. The Smith chart is most easily understood with a full scale value of 1.0. If the scale per division is less than 0.2, the format switches automatically to polar.
If the characteristic impedance of the system is not 50 Ω , modify the impedance value recognized by the analyzer using the **SET ZO** softkey in the calibration menu (see "Calibration menu").

POLAR CHART	POLAR [Re Im] (FMT POLA)
	Displays a polar format.
LINEAR MAGNITUDE	LIN MAG (FMT LINM)
	Displays the linear magnitude format. This is a Cartesian format used for unitless measurements such as reflection coefficient magnitude (ρ) or transmission coefficient magnitude (τ), and for linear measurement units. It is used for display of conversion parameters.
SWR	SWR (FMT SWR)
	Reformats a reflection measurement into its equivalent SWR (standing wave ratio) value. SWR is equivalent to $(1+ \rho)/(1- \rho)$, where ρ is the reflection coefficient.
REAL	REAL (FMT REAL)
	Displays only the real (resistive) portion of the measured data on a Cartesian format. This is similar to the linear magnitude format, but can show both positive and negative values.
IMAGINARY	IMAGINARY (FMT IMAG)
	Displays only the imaginary (reactive) portion of the measured data on a Cartesian format. This format is similar to the real format except that reactance data is displayed on the trace instead of impedance data.
EXPANDED PHASE	EXPANDED PHASE (FMT EXPP)
	Displays the phase plot over 360° . When this is turned on, the analyzer avoids the phase plot wrap around every 360° .
ADMITTANCE CHART	ADMITTANCE [Re Im] (FMT ADMIT)
	Displays an admittance Smith chart format and displays the <i>circle data menu</i> . This used in reflection measurement to provide a readout of the data in terms of admittance.

When absolute measurement is selected (that is, **A**, **B**, or **R** is selected in the input port menu), only **LDG MAG**, **LIN MAG**, or **SWR** can be used as the measurement format.

Format

Format menu Spectrum Analyzer

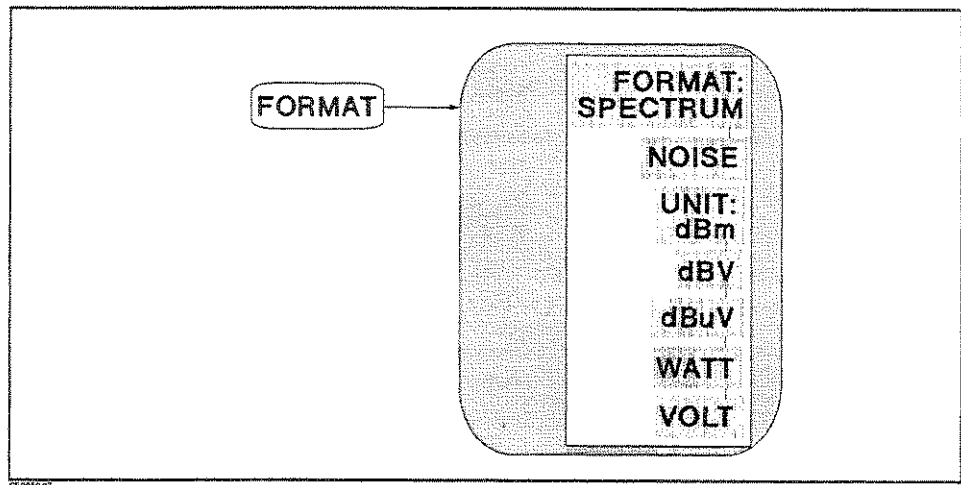

Figure 5-10. Format Menu for Spectrum Analyzer

SPECTRUM MEASUREMENT

FORMAT: SPECTRUM (FMT SPECT)

Activates a spectrum measurement. (If the noise level is activated, this softkey disables the noise level.) The amplitude unit for the reference level, display trace, and marker is selected by softkeys in this softkey menu.

NOISE MEASUREMENT

NOISE (FMT NOISE)

Activates a noise level measurement. If the marker is placed in the noise, the rms noise level is read out normalized to a 1 Hz noise power bandwidth.

UNIT

UNIT: dBm (SAUNIT DBM)

Selects dBm as amplitude unit.

dBV (SAUNIT DBV)

Selects dBV as amplitude unit.

dBµV (SAUNIT DBUV)

Selects dBµV as amplitude unit.

WATT (SAUNIT W)

Selects watt as amplitude unit.

VOLT (SAUNIT V)

Selects volt as amplitude unit.

Display

Provides access to the data math functions and other display functions including dual channel display, data hold, display allocation, active channel display title, frequency blanking, display intensity, background intensity, display intensity, background intensity, and color selection.

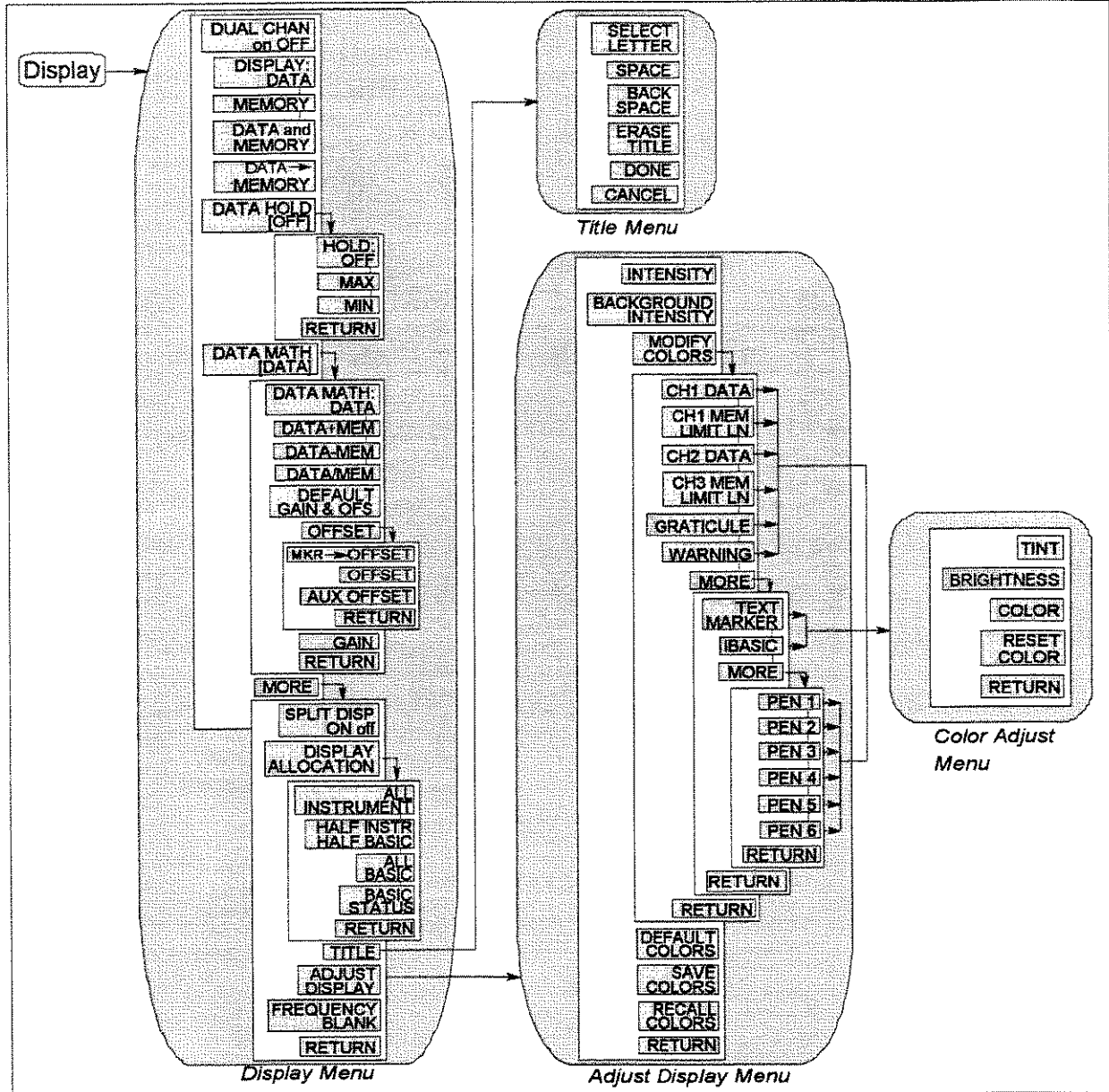

CB005035

Figure 5-11. Softkey Menus Accessed from the **Display** Key

Display

Display menu
Network Analyzer
Spectrum Analyzer

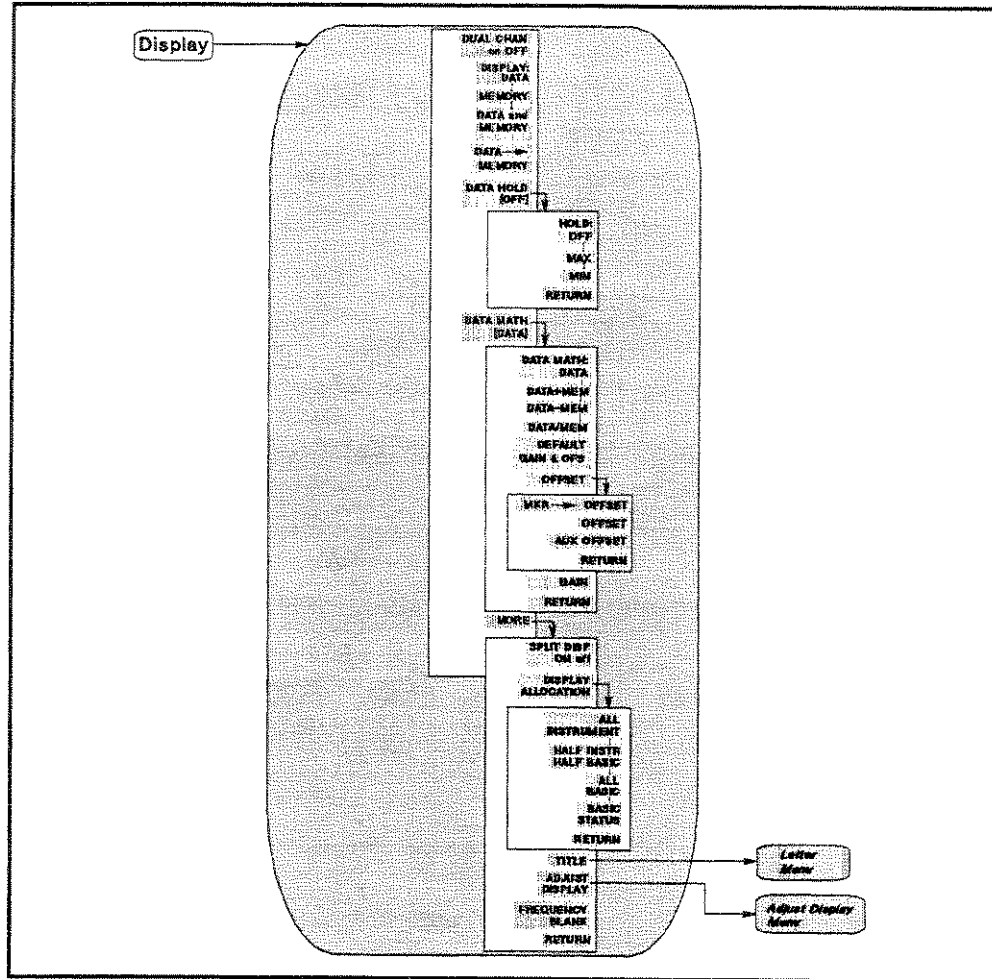

Figure 5-12. Display Menu

DUAL CHANNEL

DUAL CHAN on OFF (DUAC ON|OFF)

Toggles between the display of both measurement channels or the active channel only. This is used in conjunction with **SPLIT DISP ON off** to display both channels.

DATA

DISPLAY: DATA (DISP DATA)

Displays the current measurement data trace for the active channel.

MEMORY

MEMORY (DISP MEMO)

Displays the trace memory for the active channel. If no data is stored in memory for this channel, a warning message is displayed.

DATA and MEMORY (DISP DATM)

Displays both the current data and the memory traces.

DATA→MEMORY (DATMEM)

Stores the current active measurement data in the memory of the active channel. It then becomes the memory trace (for use in subsequent math manipulations or display). When NOP is changed, the memory trace makes be invalid.

DATA HOLD [] (DHOLD OFF|MAX|MIN)

The data hold function keeps the maximum or minimum value at each display point. Displays the following three softkeys.

MAX HOLD

HOLD: OFF

Turns off the hold function.

MIN HOLD

MAX

Holds the maximum values at each display point.

MIN

Holds the minimum values at each display point.

When the format is Smith, polar, or admittance chart format, the data hold function keeps the maximum or minimum *absolute* value.

DATA MATH

DATA MATH [] (MATH DATA|DMNM|DPLM|DDVM)

Displays the following softkeys and the **OFFSET** softkey to define the offset value using the data math function. The data math function selected is shown in brackets (**[DATA]** shows that the data math function selected **DATA**).

DATA

Turns off all data math functions.

DATA+MEM

Adds the memory to the data.

DATA-MEM

Subtracts the memory from the data.

DATA/MEM

Divides the data by the memory.

DEFAULT GAIN & OFS (DEFGO)

Returns gain and offset value back to the default values (gain = 1, offset = 0).

OFFSET VALUE **OFFSET** (DATAVAL)
 Displays the menu used to define the offset value and activates the offset value. When using Smith, Polar, and admittance chart format, **OFFSET** defines the real part of the offset value.

MKR→OFFSET (MKROFS)
 Enters the marker's amplitude value into the offset value.

AUX OFFSET VALUE (DATAOVAL)
 Defines the imaginary part of the offset value when using the Smith, Polar, and admittance chart format. If the format is not one of the above formats, this softkey performs no function.

GAIN **GAIN** (DATGAIN)
 Defines the gain value for the data math function.

<p>The data math functions displays the result of the following calculations:</p> <ul style="list-style-type: none"> ■ $(GAIN \times DATA) - OFFSET$ ■ $(GAIN \times MEMORY) - OFFSET$ ■ $(GAIN \times (DATA + MEMORY)) - OFFSET$ ■ $(GAIN \times (DATA - MEMORY)) - OFFSET$ ■ $(GAIN \times (DATA / MEMORY)) - OFFSET$

SPLIT DISPLAY **SPLIT DISP ON off** (SPLD ON|OFF)
 Toggles between a full-screen single graticule display of one or both channels, and a split display with two half-screen graticules one above the other. The split display can be used in conjunction with **DUAL CHAN ON** to show the measured data of each channel simultaneously on separate graticules.

BASIC SCREEN **DISPLAY ALLOCATION** (DISA ALLI|HIHB|ALLB|BASS)
 Displays the following menu to allocate the BASIC screen area on the display.

ALL INSTRUMENT Selects a full screen single screen or two half-screen graticules.

HALF INSTR HALF BASIC Selects two half-screens, one graticule display above the HP Instrument BASIC display.

ALL BASIC Selects a full screen single HP Instrument BASIC display.

BASIC STATUS Selects a full screen graticule and three status lines for HP Instrument BASIC under the graticule.

Note



For more information on HP Instrument BASIC, see *Using HP Instrument BASIC with the HP 4396B*.

TITLE

TITLE (TITL)

Displays the title menu in the softkey labels and the character set in the active entry area to display the title in the active channel title area on the screen.

ADJUST DISPLAY

Provides a menu for adjusting display intensity, colors, and accessing save and recall functions for modified display color sets.

FREQUENCY BLANK

FREQUENCY BLANK

Blanks the displayed frequency notation for security purposes. Frequency labels cannot be restored except by pressing **Preset** or by turning the power off and then on.

Adjust display menu

Network Analyzer
Spectrum Analyzer

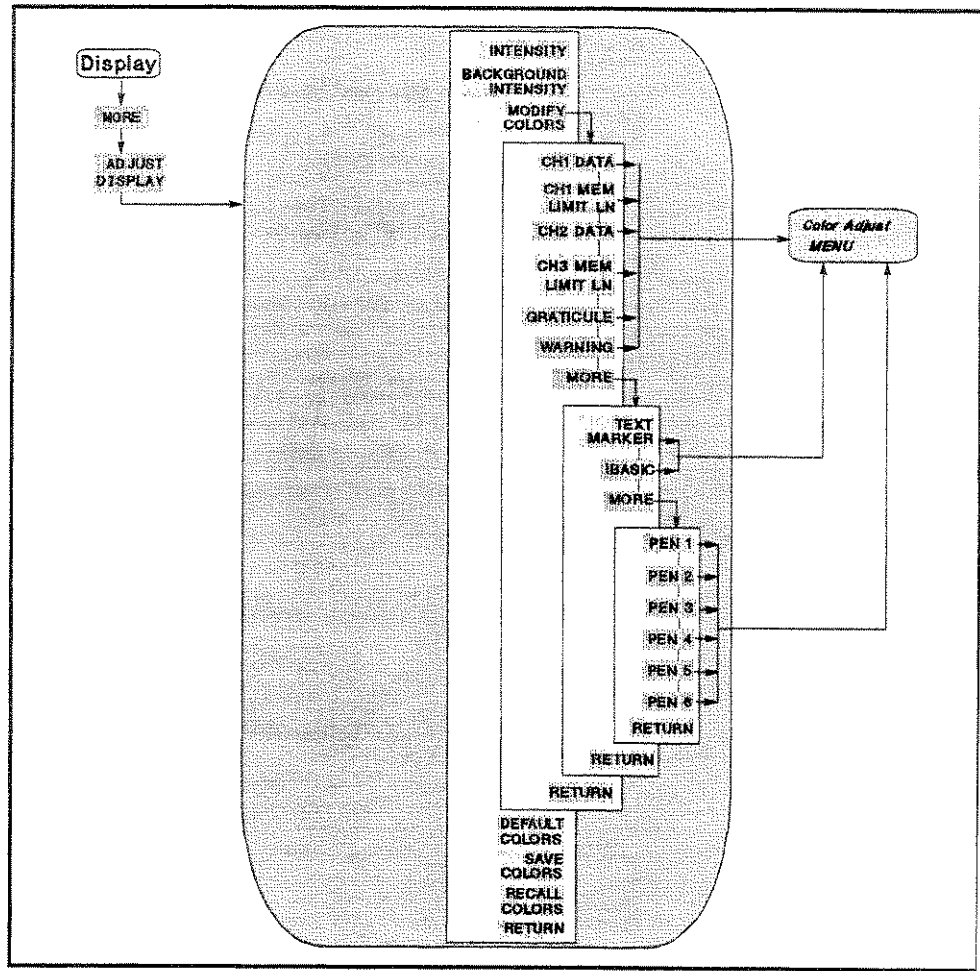

Figure 5-13. Adjust Display Menu

COLOR INTENSITY

INTENSITY (INTE)

Sets the display intensity as a percentage of the brightest setting.

BACKGROUND INTENSITY (BACI)

Sets the background intensity of the display as a percentage of the white level.

COLOR ADJUST

MODIFY COLORS

Displays the menu used for color modification of the display elements.

CH1 DATA (COLD CH1D)

Selects channel 1 data trace for color modification and displays the *color adjust menu*.

CH1 MEM/LIMIT LINE (COLO CH1M)

Selects channel 1 memory trace and limit line for color modification and displays the *color adjust menu*.

CH2 DATA (COLO CH2D)

Selects channel 2 data trace for color modification and displays the *color adjust menu*.

CH2 MEM/LIMIT LINE (COLO CH2M)

Selects channel 2 memory and the reference line and limit line for color modification and displays the *color adjust menu*.

GRATICULE (COLO GRAT)

Selects the graticule for color modification and displays the *color adjust menu*.

WARNING (COLO WARN)

Selects the warning annotation for color modification and displays the *color adjust menu*.

TEXT MARKER (COLO TEXT)

Selects all the non-data text for color modification (for example: softkey labels) and displays the *color adjust menu*.

IBASIC (COLO IBT)

Selects the text on the BASIC screen for color modification and displays the *color adjust menu*.

MORE in this menu displays softkeys to select a numbered pen for color modification. The pens are used by the HP Instrument BASIC graphic commands.

PEN COLOR

PEN 1 (COLO PEN1)

Selects pen 1 for color modification and displays the *color adjust menu*.

PEN 2 (COLO PEN2)

Selects pen 2 for color modification and displays the *color adjust menu*.

PEN 3 (COLO PEN3)

Selects pen 3 for color modification and displays the *color adjust menu*.

PEN 4 (COLO PEN4)

Selects pen 4 for color modification and displays the *color adjust menu*.

PEN 5 (COLO PEN5)

Selects pen 5 for color modification and displays the *color adjust menu*.

PEN 6 (COLO PEN6)

Selects pen 6 for color modification and displays the *color adjust menu*.

DEFAULT COLORS (DEFC)

Returns all the color settings back to the factory-set default values.

SAVE COLOR

SAVE COLORS (SVCC)

Saves the modified version of the color set to the non-volatile memory.

RECALL COLOR

RECALL COLORS (RECC)

Recalls the previously saved modified version of the color set from the non-volatile memory. **RECALL COLORS** appears only when a color set has been saved.

Color adjust menu

Network Analyzer
Spectrum Analyzer

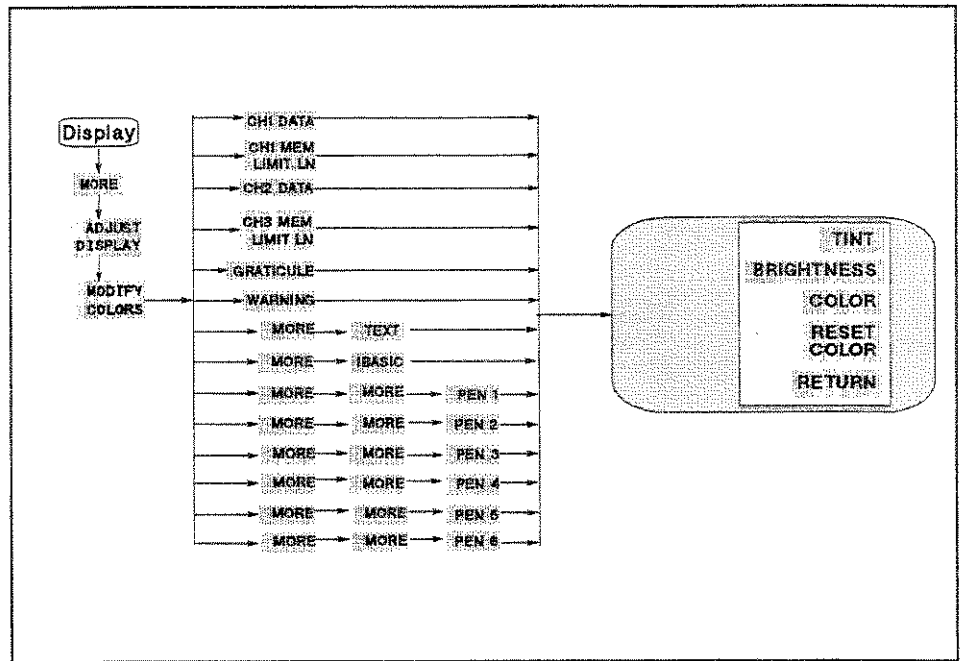

Figure 5-14. Color Adjust Menu

TINT (TINT)

Adjusts the hue of the chosen attribute.

BRIGHTNESS (CBRI)

Adjusts the brightness of the color being modified.

COLOR (COLOR)

Adjusts the degree of whiteness of the color being modified.

DEFAULT COLOR RESET COLOR (RSCO)

Resets the color being modified to the default color.

Color consists of the following three parameters:	
Tint	The continuum of hues on the color wheel, ranging from red through green and blue, and back to red.
Brightness	A measure of the brightness of the color.
Color	The degree of whiteness of the color. A scale from white to pure color.

Display

Letter menu

Network Analyzer
Spectrum Analyzer

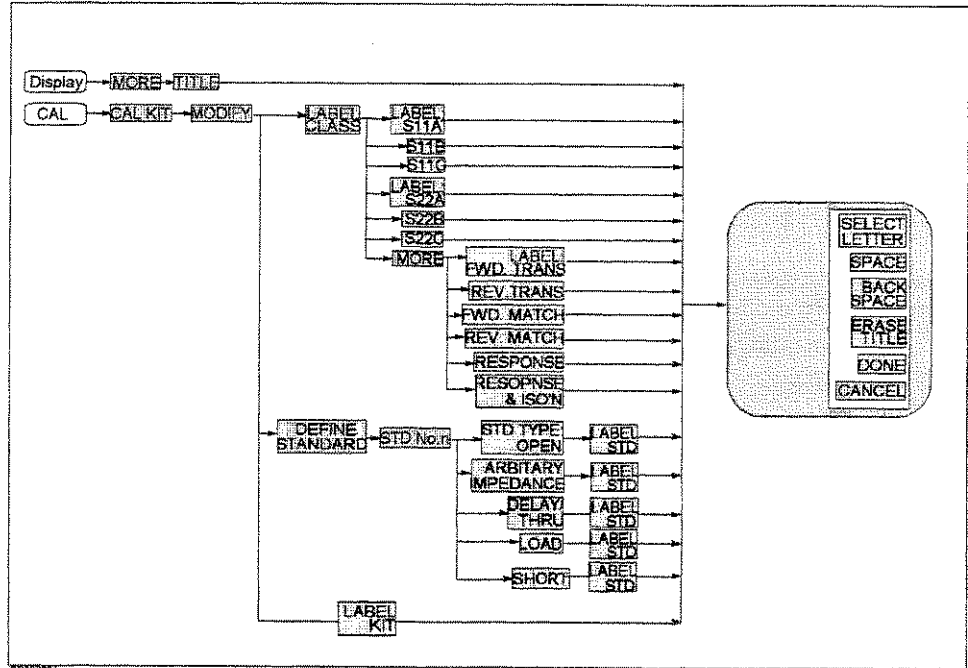

Figure 5-15. Letter Menu

ENTER CHARACTERS

SELECT LETTER

Selects the letter pointed to by the arrow "↑" on the screen. The arrow can be moved by rotating the knob. Three sets of letters can be scrolled using the step keys, \uparrow and \downarrow .

SPACE

Inserts a space in the title.

BACK SPACE

Deletes the last character entered.

ERASE TITLE

Deletes the entire title.

DONE

Terminates the title entry and returns to the display more menu

CANCEL

Cancels the title entry and returns to the display more menu without any change.

Scale reference menu

Network Analyzer

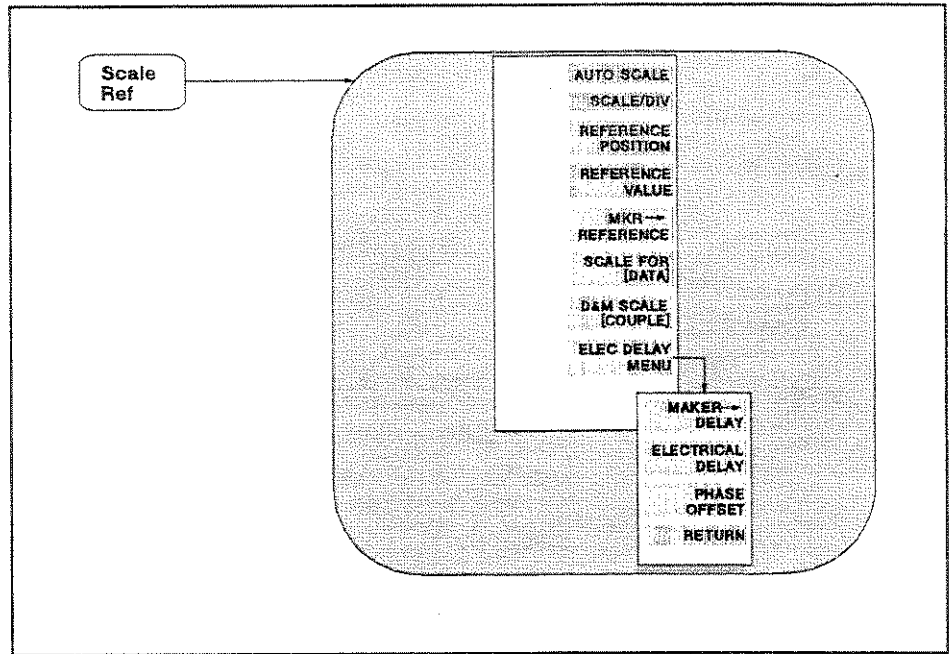

Figure 5-16. Scale Reference Menu for Network Analyzer

AUTO SCALING

AUTO SCALE (AUTO)

Brings the trace data (defined by the **SCALE FOR** key) in view on the display with one keystroke. Sweep values are not affected, only scale and reference values. The analyzer determines the smallest possible scale factor that will put all displayed data onto the vertical graticule.

SCALE/DIV (SCAL)

Changes the response value scale per division of the displayed trace. In Smith, polar, and admittance chart formats, this refers to the full scale value at the outer circumference and is identical to the reference value.

REFERENCE

REFERENCE POSITION (REFP)

Sets the position of the reference line on the graticule of a Cartesian display (with 0 at the bottom line of the graticule and 10 at the top line). It has no effect on a Smith, polar or admittance chart format. The reference position is indicated with a small triangle and a dashed line just outside the graticule, on the left.

REFERENCE VALUE (REFV)

Changes the value of the reference line, moving the measurement trace correspondingly. In Smith, polar and admittance chart formats, the reference value is the same as the scale and is the value of the outer circle.

MKR→REFERENCE (MKRREF)

Makes the reference value equal to the marker's absolute value (regardless of the delta marker value). The marker is effectively moved to the reference line position. In Smith, polar and admittance chart formats this function makes the full scale value at the outer circle equal to the marker response value.

SCALE FOR [] (SCAF DATA|MEMO)

Selects one of the "DATA" and "MEMORY" traces to be scaled by prior functions in this menu. The "DATA" and "MEMORY" traces are available using the *display menu* accessed from the **Display** key.

SCALE COUPLING

D&M SCALE [] (SCAC ON|OFF)

Couples or uncouples the "DATA" and "MEMORY" traces to be scaled by prior functions in this menu. This is valid only for those traces obtained by the *display menu* accessed from the **Display** key.

ELECTRICAL DELAY

ELEC DELAY MENU

Displays softkeys to add or subtract a linear phase slope relative to frequency or a constant phase.

MKR→DELAY (MKRDELA)

Enters the group delay at the marker point of a fixed frequency aperture, 20 % of the span, to the electrical delay to balance the phase of the DUT. This effectively flattens the phase trace around the marker and can measure electrical length or deviation from linear phase. Additional electrical delay adjustment is required for DUTs without constant group delay over the measured frequency span. Because this feature adds phase to a variation in phase versus frequency, it is applicable only for ratioed input

ELECTRICAL DELAY (ELED)

Adjusts the electrical delay to balance the phase shift of the DUT.

PHASE OFFSET

PHASE OFFSET (PHAO)

Adds or subtracts a phase offset that is constant with frequency (rather than linear). This is independent of **MKR→DELAY** and **ELECTRICAL DELAY**

Scale reference menu

Spectrum Analyzer

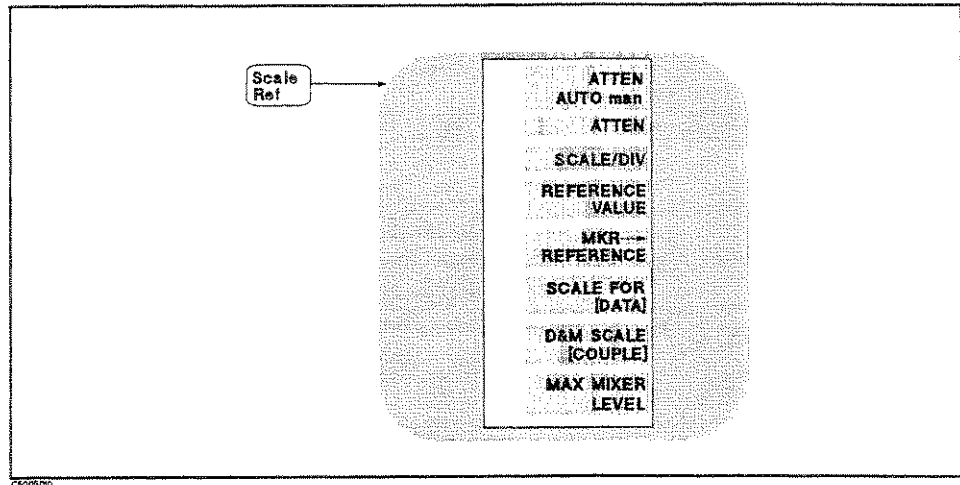

Figure 5-17. Scale Reference Menu for Spectrum Analyzer

AUTO ATTENUATOR

ATTEN AUTO man (ATT AUTO ON|OFF)

Toggles the spectrum analyzer's input attenuator at input S between automatic and manual. When the automatic attenuator is selected, the value selected ensures that the level meets the following equation

$$\text{Attenuator value(dB)} = (\text{Reference value}) - (\text{Max mixer level})$$

ATTEN (ATT)

Changes the input attenuation when input S is selected. Because the attenuators at inputs R, A, and B are fixed, if either R, A, or B is selected, you can enter the value but not change it.

SCALE/DIV (SCAL)

Changes the response value scale per division of the displayed trace.

REFERENCE

REFERENCE VALUE (REFV)

Changes the value of the reference line, moving the measurement trace correspondingly.

MKR--REFERENCE (MKRREF)

Makes the reference value equal to the marker's absolute value (regardless of the delta marker value). The marker is effectively moved to the reference line position.

SCALE FOR [] (SCAF DATA|MEMO)

Selects one of the "DATA" and "MEMORY" traces to be scaled by prior functions in this menu. The "DATA" and "MEMORY" traces are available using the *display menu* accessed from the **Display** key.

Scale Ref

SCALE COUPLING

D&M SCALE [] (SCAC ON|OFF)

Couples or uncouples the "DATA" and "MEMORY" traces to be scaled by prior functions in this menu. This is valid only for those traces obtained by the *display menu* accessed from the **Display** key.

MAX MIXER LEVEL

MAX MIXER LEVEL (MAXMLEV)

Changes the maximum input mixer level. The mixer level is less than or equal to the reference level minus the attenuator setting. As the reference level changes, the input attenuator setting is changed to keep the power levels less than the selected level at the input mixer when attenuator mode is auto.

Bandwidth menu

Network Analyzer

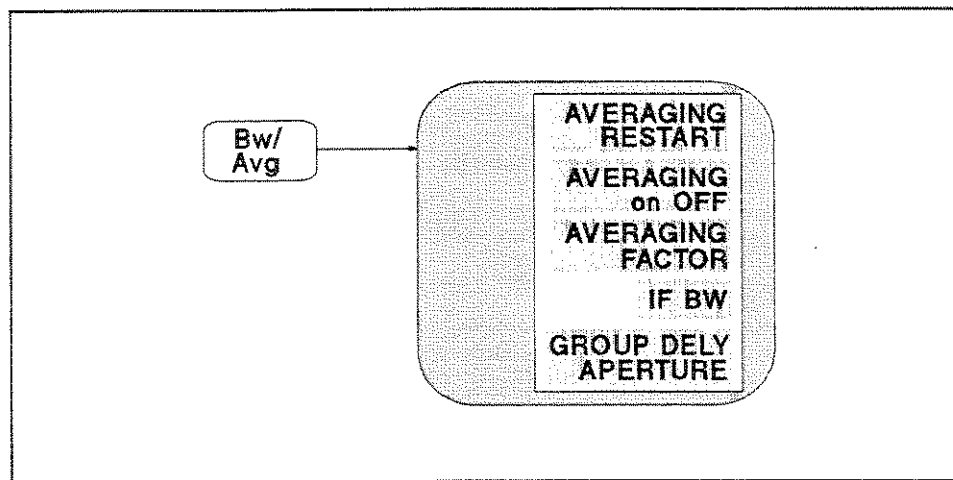

Figure 5-18. Bandwidth Menu for Network Analyzer

AVERAGING

AVERAGING RESTART (AVERREST)

Resets the sweep-to-sweep averaging and restarts the sweep count at 1 at the beginning of the next sweep. The sweep count for averaging is displayed at the left of the display.

AVERAGING on OFF (AVER ON|OFF)

Turns the averaging function ON or OFF for the active channel. When averaging is ON, "Avg" is displayed in the status notations area at the left of the display (along with the sweep count for the averaging factor). Whenever an instrument state change affecting the measured data is made, the sweep count for averaging is reset to 1.

At the start of averaging or following **AVERAGING RESTART**, averaging starts at 1 and averages each new sweep into the trace until it equals the specified averaging factor. The sweep count is displayed in the status notations area below "Avg" and updated each sweep as it increments. When the specified averaging factor is reached, the trace data continues to be updated, weighted by that averaging factor.

AVERAGING FACTOR (AVERFACT)

Makes the averaging factor the active function. Any value up to 999 can be used.

IF BANDWIDTH

IF BW (BW)

Selects the bandwidth value for IF bandwidth reduction. Allowed values (in Hz) are 10, 30, 100, 300, 1 k, 3 k, 10 k, and 40 k. Any other value will default to the closest allowed value. A narrow bandwidth provides better signal-to-noise ratio. The selected bandwidth value is shown in brackets in the softkey label.

GROUP DELAY APERTURE

GROUP DELY APERTURE (GRODAPER)

Sets the aperture for the group delay measurements as a percentage of the span. A frequency aperture Δf at the active marker is displayed under the percentage value when the format is DELAY.

See "Group Delay" in Chapter 12 for basic theory of group delay.

Bandwidth menu

Spectrum Analyzer

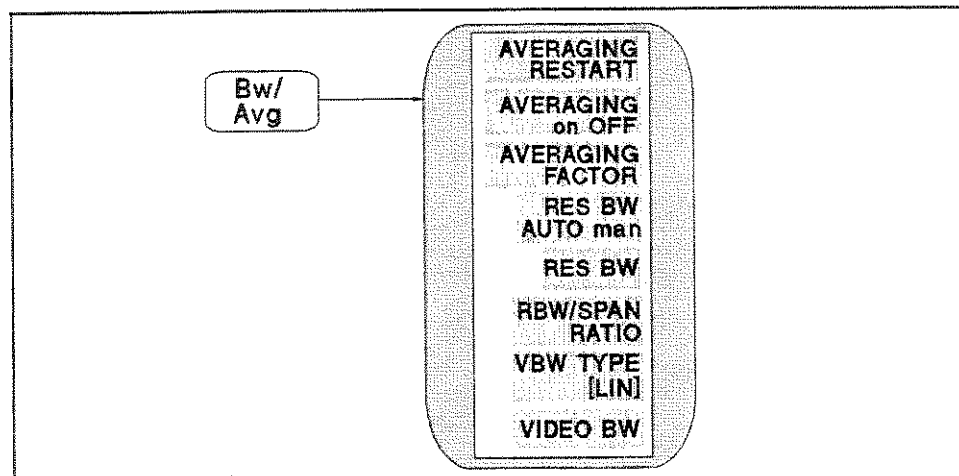

Figure 5-19. Bandwidth Menu for Spectrum Analyzer

AVERAGING

AVERAGING RESTART (AVERREST)

Resets the sweep-to-sweep averaging and restarts the sweep count at 1 at the beginning of the next sweep. The sweep count for averaging is displayed at the left of the display.

AVERAGING on OFF (AVER ON|OFF)

Turns the averaging function ON or OFF for the active channel. When averaging is ON, "Avg" is displayed in the status notations area at the left of the display (along with the sweep count for the averaging factor). Whenever an instrument state change affecting the measured data is made, the sweep count for averaging is reset to 1.

At the start of averaging or following **AVERAGING RESTART**, averaging starts at 1 and averages each new sweep into the trace until it equals the specified averaging factor. The sweep count is displayed in the status notations area below "Avg" and updated every sweep as it increments. When the specified averaging factor is reached, the trace data continues to be updated, weighted by that averaging factor.

AVERAGING FACTOR (AVERFACT)

Makes averaging factor the active function. Any value up to 999 can be used.

RESOLUTION BANDWIDTH

RES BW AUTO man (BWAUTO ON|OFF)

Toggles between automatic and manual resolution bandwidth. The automatic resolution bandwidth specifies the resolution bandwidth from SPAN and RBW/SPAN ratio. When the automatic resolution bandwidth is selected, changing SPAN can change the resolution bandwidth. If you enter a value as resolution bandwidth manually, the resolution bandwidth is automatically set to manual mode.

The automatic resolution bandwidth cannot be selected in the zero span.

RES BW [] (BW)

Selects the bandwidth value for resolution bandwidth reduction. Allowed values (in Hz) are 1, 3, 10, 30, 100, 300, 1 k, 3 k, 10 k, 30 k, 100 k, 300 k, 1 M, and 3 M. Any other value will default to the closest allowed value. A narrow bandwidth provides better signal-to-noise ratio. The selected bandwidth value is shown in brackets in the softkey label.

RBW/SPAN RATIO (BWSRAT)

Makes the RBW/SPAN ratio the active function. The RBW/SPAN ratio specifies resolution bandwidth in AUTO mode.

VIDEO BANDWIDTH

VBW TYPE [] (VBW)

Selects one of the Linear and logarithm types of VBW.

[LIN] The Linear type of VBW is selected. The analyzer enters the power (linear value) to be measured to the post-detection filter. In other words, the analyzer calculates logarithms of power after the post-detection filter.

[LOG] The logarithm type of VBW is selected. The analyzer enters the logarithm value of power to be measured to the post-detection filter, as same as a conventional analog spectrum analyzer, which uses a log-amplifier. (The analyzer calculates logarithms of power before the post-detection filter.) The logarithm VBW makes measurement result 2.5 dB lower than the actual value.

VIDEO BW (VBW)

Changes the spectrum analyzer's post-detection filter. The allowable value of video bandwidth depends on the current value of resolution bandwidth and are 1/1, 1/3, 1/10, 1/30, 1/100, and 1/300 of the current value of the resolution bandwidth.

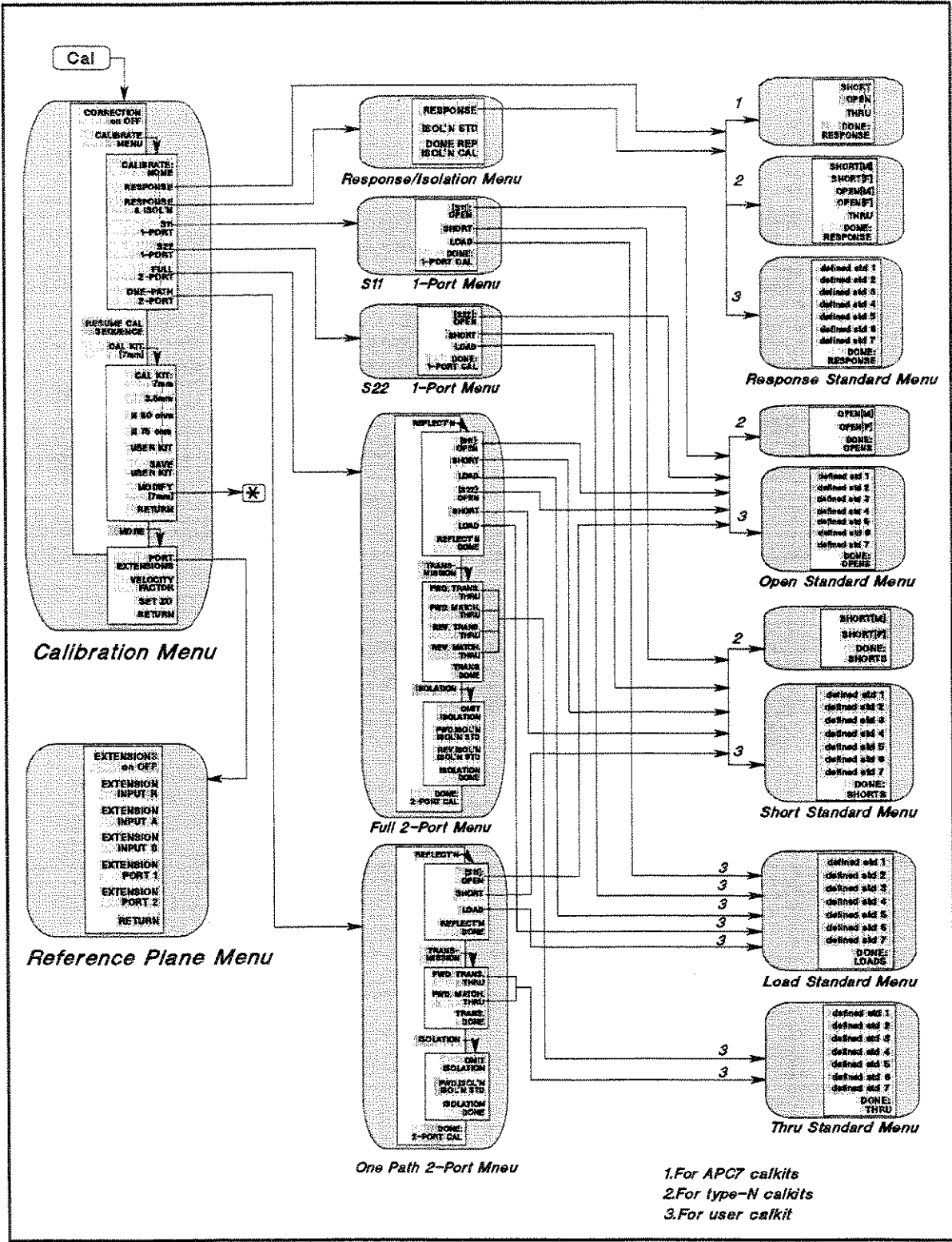

C5005036

Figure 5-20. Softkey Menus Accessed from the [Cal] Key for Network Analyzer (1/2)

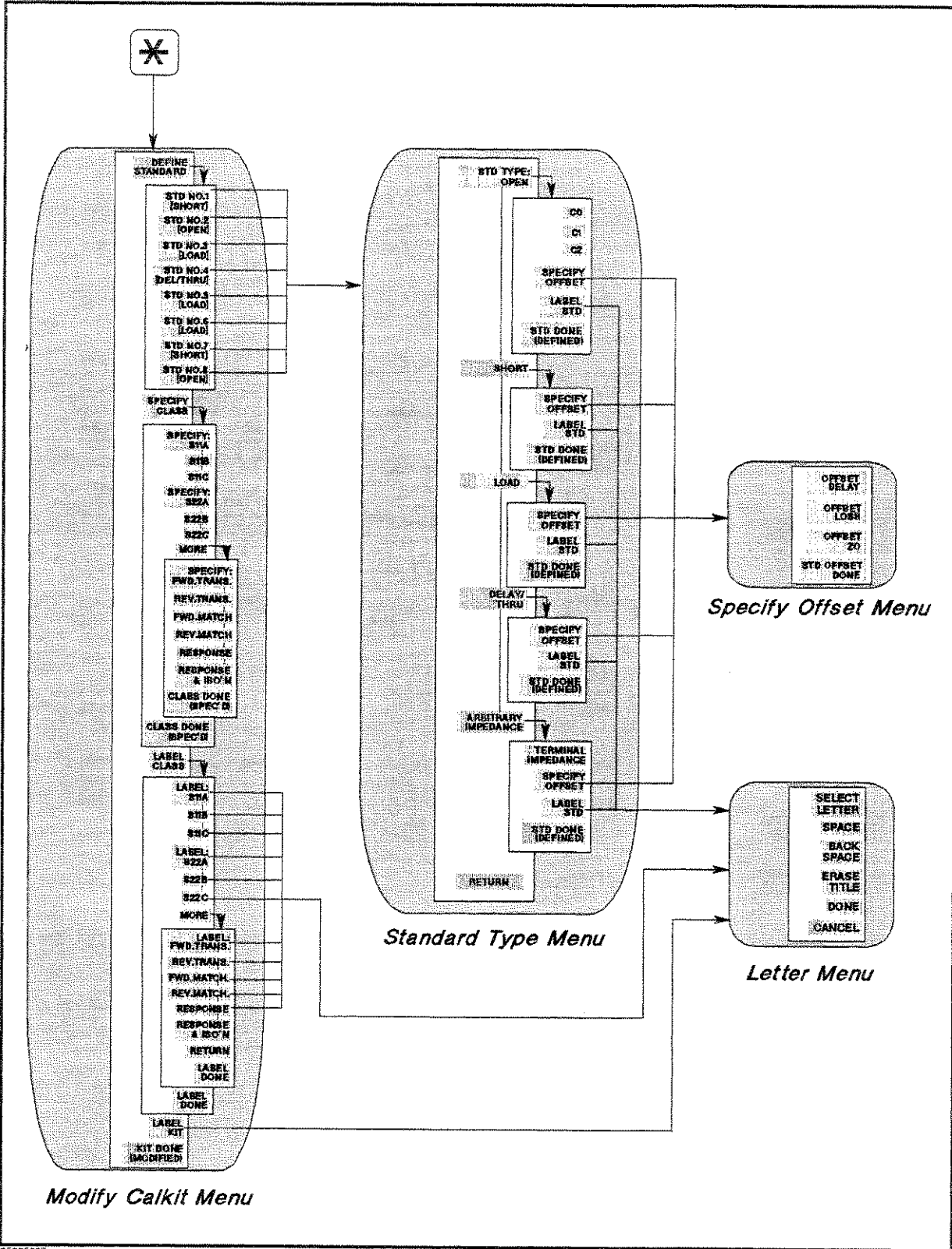

Figure 5-21. Softkey Menus Accessed from the **Cal** Key for Network Analyzer (2/2)

Calibration menu
Network Analyzer

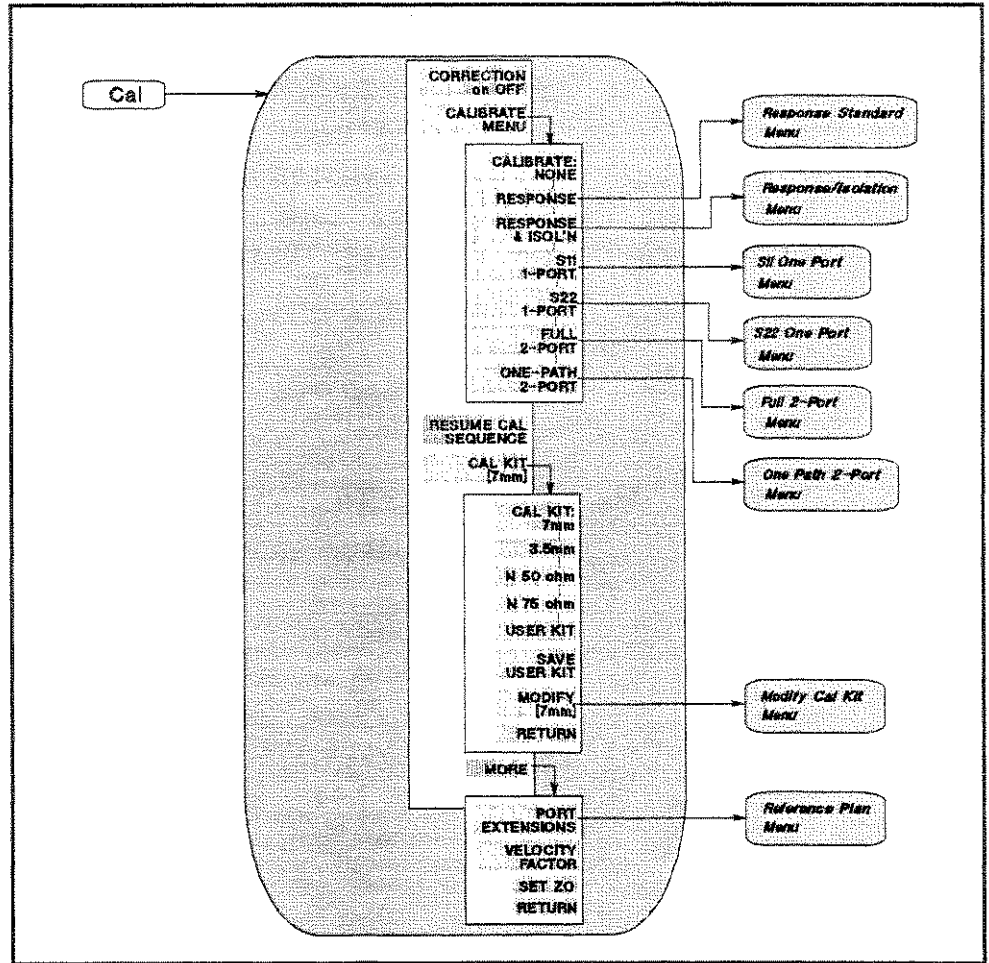

Figure 5-22. Calibration Menu

CORRECTION ON OFF **CORRECTION on OFF**

Turns error correction ON or OFF. The analyzer uses the most recent calibration data for the displayed parameter.

If one of the following sweep parameters has been changed, correction is automatically turned OFF:

- Input measurement port is changed.
- Calibration type is changed.

When "C?" or "C2?" is displayed at the left of the screen

If one of the following sweep parameters has been changed, interpolated correction is automatically turned on and the status notation is changed to "C?" or "C2?" (see "Screen display" in Chapter 2):

- Sweep range is changed to fall inside the calibrated range.
- Sweep type is changed.
- Number of points is changed.
- Power level is changed.
- IFBW is changed.
- Sweep time is changed.

When "C!" or "C2!" is displayed at the left of the screen

If one of the following sweep parameters has been changed, the status notation is changed to "C!" or "C2!" (see "Screen display" in Chapter 2). In this status, error corrections at a sweep point will be done using the calibration coefficient at the nearest calibrated frequency point or at the CW frequency.

- Sweep range is changed so both start and stop, or one of the start and stop sweep values are out the calibrated range.
- Sweep type is changed from the power sweep. (If the span is zero and the measurement frequency is equal to the CW frequency of the power sweep, the status is not changed.)
- Sweep type is changed to power sweep and CW frequency is out of the calibration range.

A calibration must be performed before correction can be turned on. If no valid calibration exists, the message "CALIBRATION REQUIRED" is displayed.

It is recommended that calibration data be saved on the built-in disk, using the capabilities described in "Save" in Chapter 8.

CALIBRATE MENU

Displays the menu that provides several accuracy enhancement procedures ranging from a simple frequency response calibration to a full two-port calibration. At the completion of a calibration procedure, correction is automatically turned on, and the notation "Cor" or "C2" is displayed at the left of the screen.

CALIBRATE: NONE (CALI NONE)

This softkey is underlined if no calibration has been performed or if the calibration data has been cleared. Unless a calibration is saved on the internal disk, the calibration data is lost when **Preset** is pressed, power is cycled on and off, or if an instrument state is recalled.

RESPONSE

RESPONSE (CALI RESP)

Displays the frequency response calibration. This is the simplest and fastest accuracy enhancement procedure. However, it should only be used when extreme accuracy is not required. It effectively removes the frequency response errors of the test setup for reflection or transmission measurements.

For transmission-only measurements or reflection-only measurements, only a single calibration standard is required with this procedure. The standard for transmission measurements is a THRU standard and for reflection measurements it can be either an OPEN or a SHORT standard. If more than one device is measured, only the data for the last device is retained. The procedures for response calibration for a reflection measurement and a transmission measurement are described in the *HP 4396B Task Reference*.

RESPONSE AND ISOLATION

RESPONSE & ISOL'N (CALI RAI)

Displays the menus used to perform a response and isolation measurement calibration (used to measure devices with wide dynamic range). This procedure effectively reduces the same errors as the response calibration. In addition, it effectively reduces the isolation (crosstalk) error in transmission measurements or the directivity error in reflection measurements. In addition to the devices required for a simple response calibration, an isolation standard is required. The standard normally used to correct for isolation is an impedance-matched LOAD (usually 50 or 75 Ω) standard. Response and directivity calibration procedures for reflection and transmission measurements are provided in the *HP 4396B Task Reference*.

1-PORT CAL

S11 1-PORT (CALI S111)

Provides a measurement calibration for reflection-only measurements of one-port devices or properly terminated two-port devices, at port 1 of an S-parameter test set or the test port of a transmission/reflection test kit. This procedure effectively reduces the directivity, source match, and frequency response errors of the test setup. It provides a higher level of measurement accuracy than the response and isolation calibration. It is the most accurate calibration procedure for reflection-only measurements. Three standard devices are required: a SHORT, an OPEN, and an impedance-matched LOAD. The procedure for performing an S_{11} one-port calibration is described in the *HP 4396B Task Reference*.

S22 1-PORT (CALI S221)

This softkey is similar to **S11 1-PORT**. It is used for reflection-only measurements of one-port devices or properly terminated two-port devices in the reverse direction (that is, for devices connected to port 2 of the S-parameter test set).

2-PORT CAL

FULL 2-PORT (CALI FUL2)

Displays the series of menus used to perform a complete calibration to measure all four S-parameters of a two-port device. This is the most accurate calibration for measurements of two-port devices. It effectively reduces all correctable systematic errors (directivity, source match, load match, isolation, reflection tracking, and transmission tracking) in both the forward and the reverse direction. Isolation correction can be omitted for measurements of devices with limited dynamic range.

The standards required for this procedure are a SHORT, an OPEN, a THRU, and an impedance-matched LOAD (two LOADs if isolation correction is required). An S-parameter test set is required. The procedure is described in the *HP 4396B Task Reference*.

ONE PATH 2-PORT (CALI ONE2)

Displays the series of menus used to perform a high-accuracy, two-port calibration without an S-parameter test set. This calibration procedure effectively reduces directivity, source match, load match, isolation, reflection tracking, and transmission tracking errors in one direction only. Isolation correction can be omitted for measurements of devices with limited dynamic range. (The DUT must be manually reversed between sweeps to accomplish measurement of both input and output responses.) The required standards are a SHORT, an OPEN, a THRU, and an impedance-matched LOAD. The procedure for performing a one-path 2-port calibration is described in the *HP 4396B Task Reference*.

RESUME CAL

RESUME CAL SEQUENCE (RESC)

Eliminates the need to restart a calibration sequence that was interrupted to access some other menu. Goes back to the point where the calibration sequence was interrupted.

CAL KIT

CAL KIT [7mm]

Displays the menu that selects one of the default calibration kits available for different connector types. This in turn displays additional softkeys used to define calibration standards other than those in the default kits (see "Modifying Calibration Kits" in Chapter 12). When a calibration kit has been specified, its connector type is displayed in brackets in the softkey label.

CAL KIT: 7mm (CALK APC7)

Selects the 7 mm cal kit model.

3.5mm (CALK APC35)

Selects the 3.5 mm cal kit model.

N 50 ohm (CALK N50)

Selects the 50 Ω type-N model.

N 75 ohm (CALK N75)Selects the 75 Ω type-N model.

USER CAL KIT

USER KIT (CALK USED)

Selects a cal kit model defined or modified by the user. For information, see "Modifying Calibration Kits" in Chapter 12.

SAVE USER KIT (SAVEUSEK)

Stores the user-modified or user-defined kit into memory, after it has been modified.

MODIFY CAL KIT

MODIFY [] (MODI1)

Displays the modify cal kit menu, where a default cal kit can be user-modified.

PORT EXTENSION

PORT EXTENSIONSGoes to the *reference plane* menu that extends the apparent location of the measurement reference plane or input.

VELOCITY FACTOR

VELOCITY FACTOR (VELOFACT)

Enters the velocity factor used by the analyzer to calculate equivalent electrical length.

Velocity factor should be less than 1For example, the velocity factor of Teflon (V_f) is:

$$V_f = \frac{1}{\sqrt{\epsilon_R}}$$

$$= 0.666$$

CHARACTERISTIC IMPEDANCE

SET Z0 (SETZ)Sets the characteristic impedance used by the analyzer in calculating measured impedance with Smith chart markers and conversion parameters. If the test set used is an HP 85046B test set, or an HP 87512B Transmission/Reflection Test Kit, set Z_0 to 75 Ω . Characteristic impedance must be set correctly before calibration procedures are performed.

The models for the Cal Kits correspond to the standard calibration kits available as accessories.

7 mm	HP 85031B 7 mm calibration kit
3.5 mm	HP 85033C 3.5 mm calibration kit
50 Ω Type-N	HP 85032B 50 Ω type-N calibration kit
75 Ω Type-N	HP 85036B 75 Ω type-N calibration kit

Cal kits other than those listed can be used. For the highest accuracy, the more closely the model matches the device, the better.

In addition to the four predefined cal kits, a fourth choice is a "user kit" that is defined or modified by the user. This is described under "Modifying Calibration Kits" in Chapter 12.

Differences between PORT EXTENSIONS and ELECTRICAL DELAY	
Main Effect	
PORT EXTENSIONS	ELECTRICAL DELAY
The end of a cable becomes the test port plane for all S-parameter measurements.	Compensates for the total electrical length of cables (for the current type of measurement only). <ul style="list-style-type: none"> ■ Reflection = 2 times cable's electrical length. ■ Transmission = 1 times cable's electrical length.
Measurements Affected	
PORT EXTENSIONS	ELECTRICAL DELAY
All S-parameters.	Only the currently selected measurement parameter.
Electrical Compensation	
PORT EXTENSIONS	ELECTRICAL DELAY
Intelligently compensates for 1 times or 2 times the cable's electrical delay, depending on which S-parameter is computed.	Only compensates as necessary for the currently selected measurement parameter.

Purpose and Use of Different Calibration Procedures			
Calibration Procedure	Corresponding Measurement	Errors Reduced	Standard Devices
Response	Transmission or reflection measurement when the highest accuracy is not required.	Freq. response	THRU for trans., OPEN or SHORT for reflection
Response & isolation	Transmission of high insertion loss devices or reflection of high return loss devices. Not as accurate as 1-port or 2-port calibration.	Frequency response plus isolation in transmission or directivity in reflection	Same as response plus isolation std (LOAD)
S ₁₁ 1-port	Reflection of any one-port device or well terminated two-port device.	Directivity, source match, frequency response.	SHORT and OPEN and LOAD
S ₂₂ 1-port	Reflection of any one-port device or well terminated two-port device.	Directivity, source match, freq. response.	SHORT and OPEN and LOAD
Full 2-port	Transmission or reflection of highest accuracy for two-port devices. HP 85046A, B S-parameter Test Set is required.	Directivity, source match, load match, isolation, frequency response, forward and reverse.	SHORT and OPEN and LOAD and THRU (2 LOADs for isolation)
One-path 2-port	Transmission or reflection of highest accuracy for two-port devices. (Reverse DUT between forward and reverse measurements.)	Directivity, source match, load match, isolation, frequency response, forward direction only.	SHORT and OPEN and LOAD and THRU

Response standard menu

Network Analyzer

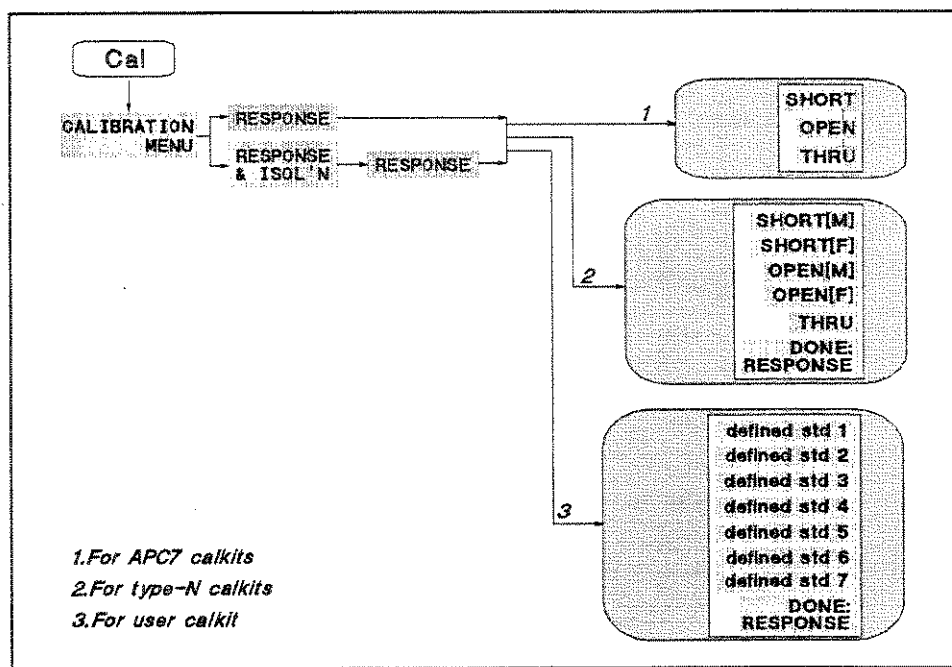

Figure 5-23. Response Standard Menu

RESPONSE FOR 3.5 MM/7MM CAL KITS

SHORT (STANA)

Measures SHORT standard of 7 mm or 3.5 mm cal kit for the response calibration.

OPEN (STANB)

Measures OPEN standard of 7 mm or 3.5 mm cal kit for the response calibration.

THRU (STANC)

Measures THRU standard of 7 mm or 3.5 mm cal kit for the response calibration.

RESPONSE FOR TYPE-N CAL KITS

SHORT [M] (STANA)

Measures SHORT standard of type-N cal kits connected to the type-N male test port connector for the response calibration. **[M]** indicates that the test port connector is male, it does not indicate the connector type of the standard.

SHORT [F] (STANB)

Measures SHORT standard of type-N cal kits connected to the type-N female test port connector for the response calibration. **[F]** indicates that the test port connector is female, it does not indicate the connector type of the standard.

OPEN [M] (STANC)

Measures OPEN standard of type-N cal kits connected to the type-N male test port connector for the response calibration. [M] indicates that the test port connector is male, it does not indicate the connector type of the standard.

OPEN [F] (STAND)

Measures OPEN standard of type-N cal kits connected to the type-N female test port connector for the response calibration. [F] indicates that the test port connector is female, it does not indicate the connector type of the standard.

THRU (STANE)

Measures THRU standard of type-N cal kits for the response calibration.

RESPONSE FOR USER CAL KIT**defined std 1 (STANA)****defined std 2 (STANB)****defined std 3 (STANC)****defined std 4 (STAND)****defined std 5 (STANE)****defined std 6 (STANF)****defined std 7 (STANG)**

These softkeys measure the standard defined by the user for the response calibration. When only one standard is assigned to the response calibration, this softkey menu is not displayed and the standard is measured immediately.

DONE: RESPONSE (RESPDONE)

Completes the response calibration and computes and stores the error coefficients. The correction menu is displayed with **CORRECTION ON**.

[M] and **[F]** indicate the test port connector type.

By convention, when the connector type is provided in parentheses for a calibration standard, it refers to the connector type of the test port connector, not the connector type of the standard. For example, **SHORT [M]** indicates that the test port connector is male, not the SHORT connector.

Response/Isolation Menu

Network Analyzer

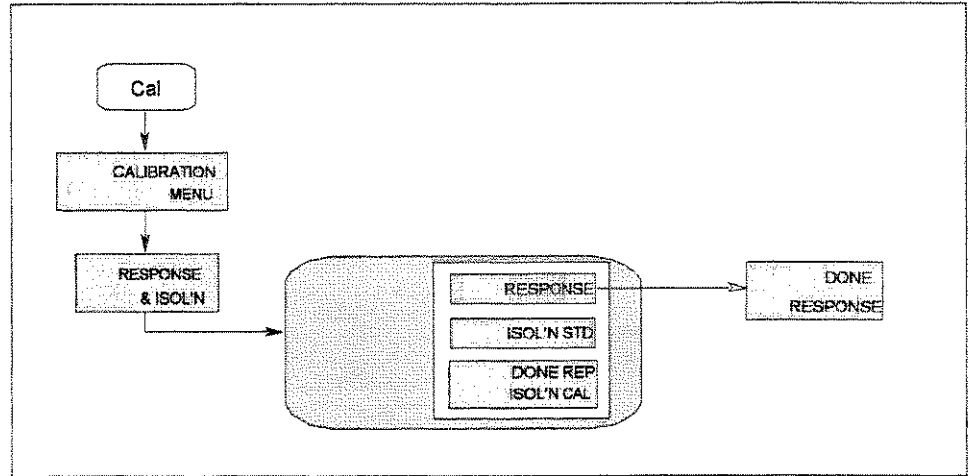

CB005016

Figure 5-24. Response and Isolation Menu

RESPONSE

RESPONSE (RAIRESP)

Displays the *response standard menu* that measures the standard for response calibration.

ISOLATION

ISOL'N STD (RAIISOL)

Displays the menu that performs an isolation measurement calibration.

DONE RESP ISOL'N CAL (RAID)

Completes the response and isolation calibration and computes and stores the error coefficients. The correction menu is displayed with **CORRECTION ON**.

S11 1-Port Menu

Network Analyzer

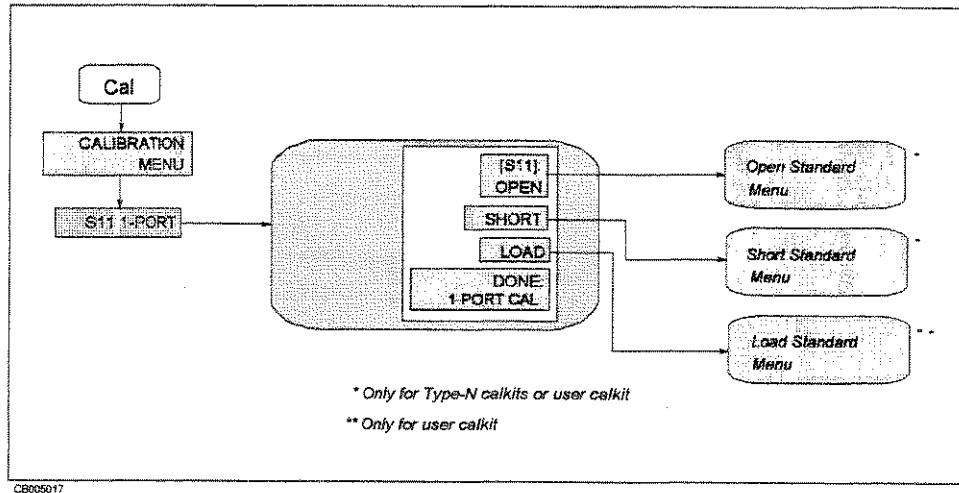

Figure 5-25. S11 1-Port Menu

S11 1-PORT CAL

[S11]: OPEN (CLASS11A)

When the cal kit is a 7 mm or 3.5 mm cal kit, this softkey measures the OPEN standard and then the softkey label is underlined. Or, this softkey displays the *open standard menu* that selects an OPEN standard and measures the standard when the cal kit is 50 Ω or 75 Ω type-N.

SHORT (CLASS11B)

When the cal kit is a 7 mm or 3.5 mm cal kit, this softkey measures the short standard and then the softkey label is underlined. Or, this softkey displays the *short standard menu* that selects a short standard and measures the standard when the cal kit is 50 Ω or 75 Ω type-N.

LOAD (CLASS11C)

When the cal kit is a 7 mm or 3.5 mm cal kit, LOAD measures the load standard and then LOAD is underlined. Or, LOAD displays the *load standard menu* that selects a load standard and measures the standard when the cal kit is 50 Ω or 75 Ω type-N.

DONE: 1-PORT CAL (SAV1)

Completes the 1-port calibration. The error coefficients are computed and stored. The correction menu is displayed with CORRECTION ON. If this key is pressed without measuring all the required standards, the message CAUTION: ADDITIONAL STANDARDS NEEDED is displayed.

S22 1-Port Menu

Network Analyzer

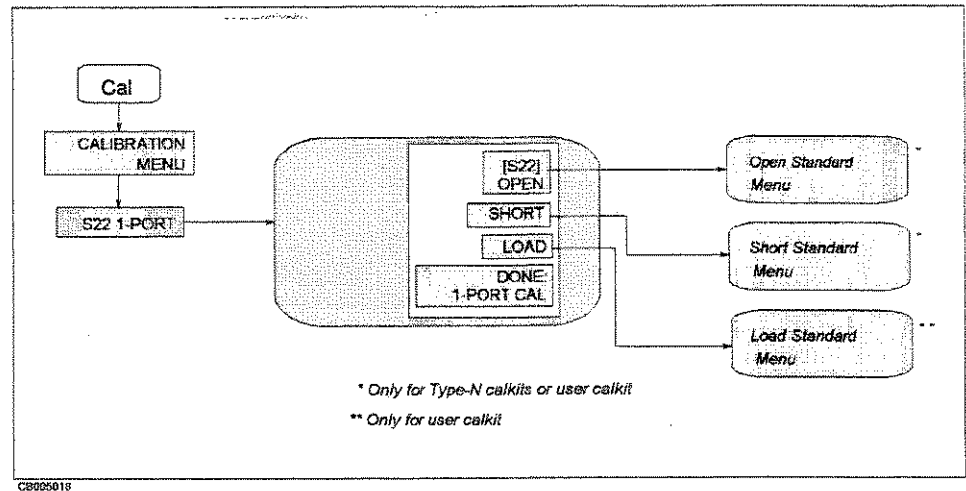

Figure 5-26. S22 1-Port Menu

S22 1-PORT CAL

[S22] : OPEN (CLASS22A)

When the cal kit is a 7 mm or 3.5 mm cal kit, this softkey measures the OPEN standard and then the softkey label is underlined. Or, this softkey displays the *open standard menu* that selects an OPEN standard and measures the standard when the cal kit is 50 Ω or 75 Ω type-N.

SHORT (CLASS22B)

When the cal kit is a 7 mm or 3.5 mm cal kit, **SHORT** measures the short standard and then **SHORT** is underlined. Or, **SHORT** displays the *short standard menu* that selects a short standard and measures the standard when the cal kit is 50 Ω or 75 Ω type-N.

LOAD (CLASS22C)

When the cal kit is a 7 mm or 3.5 mm cal kit, **LOAD** measures the load standard and then **LOAD** is underlined. Or, **LOAD** displays the *load standard menu* that selects a load standard and measures the standard when the cal kit is 50 Ω or 75 Ω type-N.

DONE: 1-PORT CAL (SAV1)

Completes the 1-port calibration. The error coefficients are computed and stored. The correction menu is displayed with **CORRECTION ON**. If this key is pressed without measuring all the required standards, the message CAUTION: ADDITIONAL STANDARDS NEEDED is displayed.

Full 2-Port Cal Menu

Network Analyzer

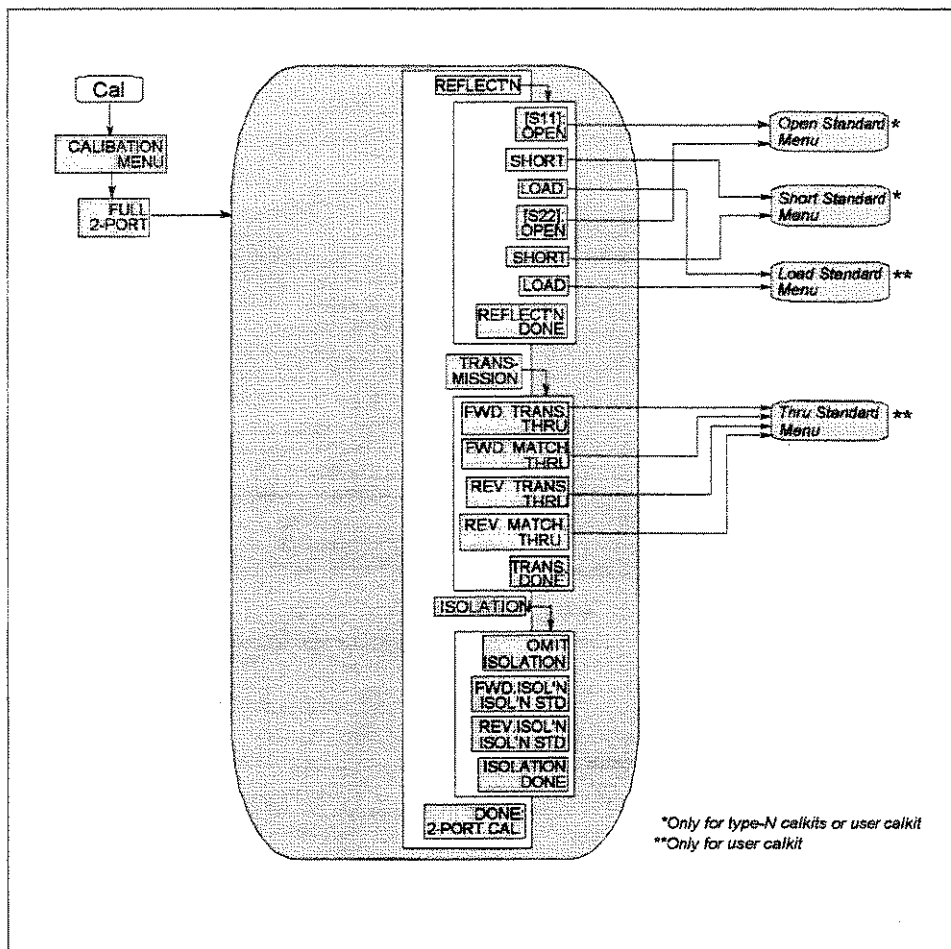

Figure 5-27. Full 2-Port Cal Menu

REFLECTION CAL

REFLECT'N (REFL)

Start the reflection calibration for full 2-port calibration and displays the menu that measures one port standards for reflection calibration.

[S11]: OPEN (CLASS11A)

When the cal kit is a 7 mm or 3.5 mm cal kit this softkey measures the OPEN standard and then the softkey label is underlined. Or, this softkey displays the *open standard menu* that selects an OPEN standard and measures the standard when the cal kit is 50 Ω or 75 Ω type-N.

SHORT (CLASS11B)

When the cal kit is a 7 mm or 3.5 mm cal kit, SHORT measures the short standard and then SHORT is underlined. Or, SHORT displays the *short standard menu* that selects a short standard and measures the standard when the cal kit is 50 Ω or 75 Ω type-N.

LOAD (CLASS11C)

When the cal kit is a 7 mm or 3.5 mm cal kit, **LOAD** measures the load standard and then **LOAD** is underlined. Or, **LOAD** displays the *load standard menu* that selects a load standard and measures the standard when the cal kit is 50 Ω or 75 Ω type-N.

[S22]: OPEN (CLASS22A)

When the cal kit is a 7 mm or 3.5 mm cal kit, this softkey measures the OPEN standard and then softkey label is underlined. Or, this softkey displays the *OPEN standard menu* that selects an the OPEN standard and measures the standard when the cal kit is 50 Ω or 75 Ω type-N.

SHORT (CLASS22B)

When the cal kit is a 7 mm or 3.5 mm cal kit, this softkey measures the short standard and then the softkey label is underlined. Or, this softkey displays the *short standard menu* that selects a short standard and measures the standard when the cal kit is 50 Ω or 75 Ω type-N.

LOAD (CLASS22C)

When the cal kit is a 7 mm or 3.5 mm cal kit this softkey measures the load standard and then the softkey label is underlined. Or, this softkey displays the *load standard menu* that selects a load standard and measures the standard when the cal kit is 50 Ω or 75 Ω type-N.

REFLECT'N DONE (REFD)

Completes the reflection calibration for the full 2-port calibration. The error coefficients are computed and stored. Full 2-Port menu is displayed, with the **REFLECT'N** softkey underlined. If this key is pressed without measuring all the required standards, the message **CAUTION: ADDITIONAL STANDARDS NEEDED** is displayed.

TRANSMISSION CAL

TRANS-MISSION (TRANS)

Starts the transmission calibration and displays the menu that measures frequency response and load match for transmission calibration.

FWD. TRANS. THRU (FWDT)

Measures S_{21} frequency response, and then **FWD. TRANS. THRU** is underlined. If the cal kit is a user kit and two or more standards are assigned to the forward transmission class, **FWD. TRANS. THRU** displays the *THRU standard menu* that selects the THRU standard and measures it.

FWD. MATCH THRU (FWDM)

Measures S_{11} load match, and then **FWD. MATCH THRU** is underlined. If the cal kit is a user kit and two or more standards are assigned

to the forward match class, **FWD. MATCH THRU** displays the *THRU standard menu* that selects the THRU standard and measures it.

REV. TRANS. THRU (REVT)

Measures S_{12} frequency response, and then **REV. TRANS. THRU** is underlined. If the cal kit is a user kit and two or more standards are assigned to the reverse transmission class, **REV. TRANS. THRU** displays the *THRU standard menu* that selects the THRU standard and measures it.

REV. MATCH THRU (REVM)

Measures S_{22} load match, and then **REV. MATCH THRU** is underlined. If the cal kit is a user kit and two or more standards are assigned to the reverse match class, **REV. MATCH THRU** displays the *THRU standard menu* that selects the THRU standard and measures it.

TRANS. DONE (TRAD)

Completes transmission calibration. The error coefficients are calculated and stored. Full 2-Port menu is displayed, with **TRANSMISSION** underlined. If **TRANS. DONE** is pressed without measuring all the required standards, the message CAUTION: ADDITIONAL STANDARDS NEEDED is displayed.

ISOLATION

ISOLATION (ISOL)

Starts the isolation calibration and displays the menu that measures isolation.

OMIT ISOLATION (OMII)

Omits correction for isolation from the calibration when it is not required.

FWD. ISOL'N ISOL'N STD (FWDI)

Measures S_{21} isolation and then **FWD. ISOL'N ISOL'N STD** is underlined.

REV. ISOL'N ISOL'N STD (REVI)

Measures S_{12} isolation and then **REV. ISOL'N ISOL'N STD** is underlined.

ISOLATION DONE (ISOD)

Completes isolation calibration. The error coefficients are calculated and stored. The full 2-port menu is displayed, with **ISOLATION** underlined. If **ISOLATION DONE** is pressed without measuring all the required standards, the message CAUTION: ADDITIONAL STANDARDS NEEDED is displayed.

DONE: 2-PORT CAL (SAV2)

Completes the full 2-port calibration. The error coefficients are computed and stored. The correction menu is displayed with **CORRECTION ON** and the notation C2 is displayed at the left of the screen. If **DONE: 2-PORT CAL** is pressed without measuring all the required standards, the message **CAUTION: ADDITIONAL STANDARDS NEEDED** is displayed.

One-Path 2-Port Menu

Network Analyzer

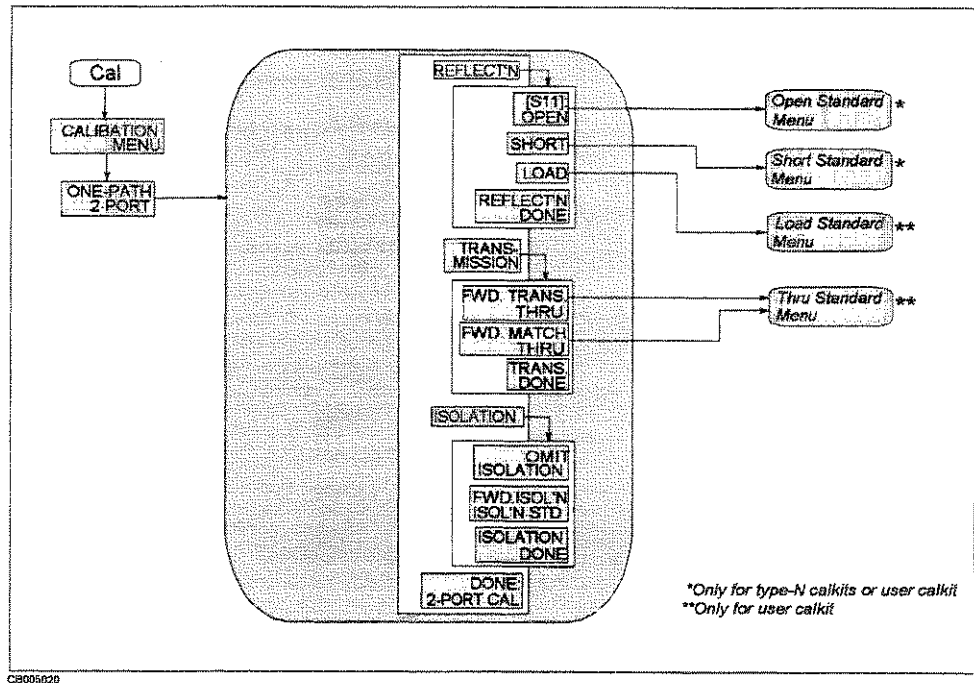

Figure 5-28. One-Path 2-Port Cal Menu

REFLECTION CAL

REFLECT'N (REFL)

Start the reflection calibration for one-path 2-port calibration and displays the menu that measures one port standards for reflection calibration.

[S11]: OPEN (CLASS11A)

When the cal kit is a 7 mm or 3.5 mm cal kit this softkey measures the OPEN standard and then the softkey label is underlined. Or, this softkey displays the *open standard menu* that selects an OPEN standard and measures the standard when the cal kit is 50 Ω or 75 Ω type-N.

SHORT (CLASS11B)

When the cal kit is a 7 mm or 3.5 mm cal kit this softkey measures the short standard and then the softkey label is underlined. Or, this softkey displays the *short standard menu* that selects a short standard and measures the standard when the cal kit is 50 Ω or 75 Ω type-N.

LOAD (CLASS11C)

When the cal kit is a 7 mm or 3.5 mm cal kit this softkey measures the load standard and then the softkey label is underlined. Or, this softkey displays the *load standard menu* that selects a load standard and measures the standard when the cal kit is 50 Ω or 75 Ω type-N.

REFLECT'N DONE (REFD)

Completes the reflection calibration for the one-path 2-port calibration. The error coefficients are computed and stored. One-path 2-Port menu is displayed, with the **REFLECT'N** softkey underlined. If this key is pressed without measuring all the required standards, the message **CAUTION:ADDITIONAL STANDARDS NEEDED** is displayed.

TRANSMISSION CAL

TRANS-MISSION (TRAN)

Starts the transmission calibration and displays the menu that measures frequency response and load match for transmission calibration.

FWD. TRANS. THRU (FWDT)

Measures S_{21} frequency response, and then the softkey is underlined. If the cal kit is user kit and two or more standards are assigned to the forward transmission class, this softkey displays the *THRU standard menu* that selects the THRU standard and measures it.

FWD. MATCH THRU (FWDM)

Measures S_{11} load match, and then the softkey is underlined. If the cal kit is user kit and two or more standards are assigned to the forward match class, this softkey displays the *THRU standard menu* that selects the THRU standard and measures it.

TRANS. DONE (TRAD)

Completes transmission calibration. The error coefficients are calculated and stored. The one-path, 2-Port menu is displayed, with the **TRANSMISSION** softkey underlined. If this key is pressed without measuring all the required standards, the message **CAUTION:ADDITIONAL STANDARDS NEEDED** is displayed.

ISOLATION

ISOLATION (ISOL)

Starts the isolation calibration and displays the menu that measures isolation.

OMIT ISOLATION (OMII)

Omits correction for isolation from the calibration when it is not required.

FWD.ISOL'N ISOL'N STD (FWDI)

Measures S_{21} isolation and then the softkey label is underlined.

REV.ISOL'N ISOL'N STD (REVI)

Measures S_{12} isolation and then the softkey label is underlined.

ISOLATION DONE (ISOD)

Completes isolation calibration. The error coefficients are calculated and stored. One-path 2-port menu is displayed, with the **ISOLATION** softkey underlined. If this key is pressed without measuring all the required standards, the message CAUTION: ADDITIONAL STANDARDS NEEDED is displayed.

DONE: 2-PORT CAL (SAV2)

Completes the one-path 2-port calibration. The error coefficients are computed and stored. The correction menu is displayed with **CORRECTION ON**, and the notation C2 is displayed at the left of the screen. If this key is pressed without measuring all the required standards, the message CAUTION: ADDITIONAL STANDARDS NEEDED is displayed.

Reference Plane Menu

Network Analyzer

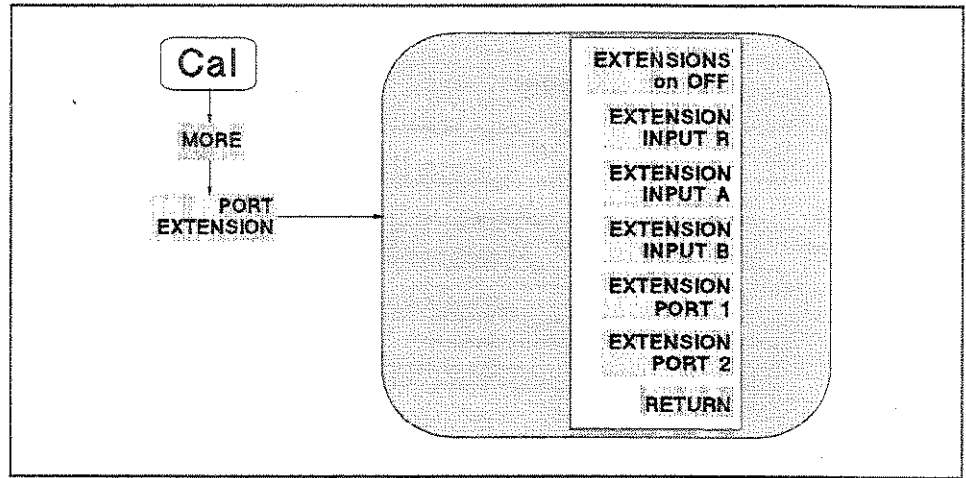

Figure 5-29. Reference Plane Menu

PORT EXTENSION

EXTENSIONS on OFF (PORE ON|OFF)

Toggles the reference plane extension mode. When this function is ON, all extensions defined below are enabled; when OFF, none of the extensions are enabled.

EXTENSION INPUT R (PORTR)

Adds electrical delay in seconds to extend the reference plane at input R to the end of the cable. This is used for all R input measurements (including S-parameters).

EXTENSION INPUT A (PORTA)

Adds electrical delay to the input A reference plane for all A input measurements (including S-parameters).

EXTENSION INPUT B (PORTB)

Adds electrical delay to the input B reference plane for all B input measurements (including S-parameters).

EXTENSION PORT 1 (PORT1)

Extends the reference plane for measurements of S_{11} , S_{21} , and S_{12} .

EXTENSION PORT 2 (PORT2)

Extends the reference plane for measurements of S_{22} , S_{12} , and S_{21} .

Modify Cal Kit Menu
Network Analyzer

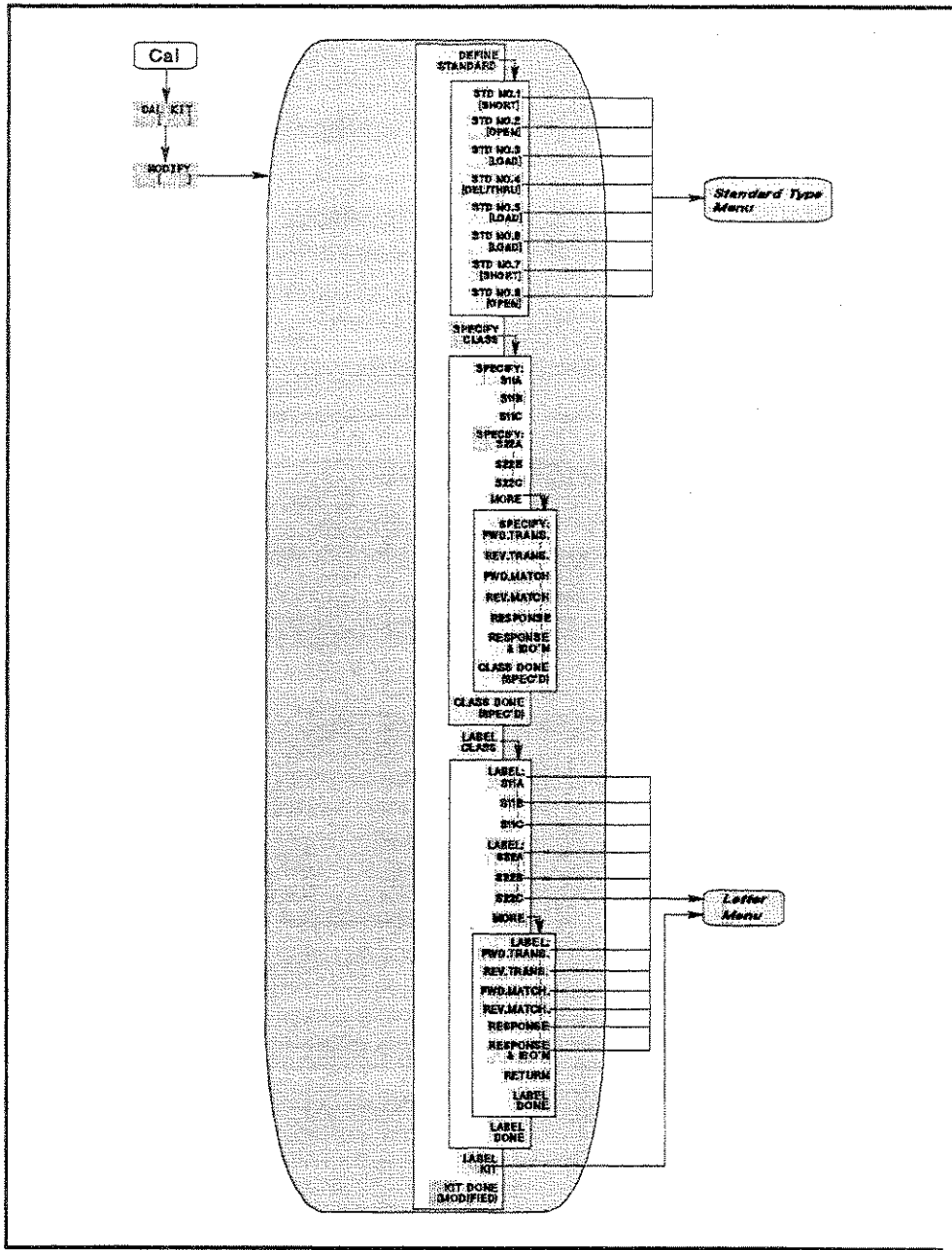

Figure 5-30. Modify Cal Kit Menu

DEFINE STANDARD

Makes the standard number the active function and brings up the define standard number menus. The standard number (1 to 8) is an arbitrary reference number used to reference standards when specifying a class. Each number is similar to a register in that it holds specific information. Each contains the selected type of device (OPEN, SHORT, or THRU) and the electrical model for that device. The standard numbers for the predefined calibration kits are as follows:

1 SHORT	5 LOAD
2 OPEN	6 LOAD
3 LOAD	7 SHORT
4 DEL/THRU	8 OPEN

STD NO.1 [] (DEFS 1)

Selects standard No.1 as the standard definition.

STD NO.2 [] (DEFS 2)

Selects standard No.2 as the standard definition.

STD NO.3 [] (DEFS 3)

Selects standard No.3 as the standard definition.

STD NO.4 [] (DEFS 4)

Selects standard No.4 as the standard definition.

STD NO.5 [] (DEFS 5)

Selects standard No.5 as the standard definition.

STD NO.6 [] (DEFS 6)

Selects standard No.6 as the standard definition.

STD NO.7 [] (DEFS 7)

Selects standard No.7 as the standard definition.

STD NO.8 [] (DEFS 8)

Selects standard No.8 as the standard definition.

SPECIFY CLASS

SPECIFY CLASS

Displays softkeys that assign a standard to a standard class. After the standards are modified, use **SPECIFY CLASS** to specify that a class consists of specific standards.

SPECIFY: S11A (SPECS11A)

Enters the standard numbers for the first class required for an S_{11} 1-port calibration. (For predefined cal kits, this is OPEN (for the 7 mm) or OPENS (for type-N).)

S11B (SPECS11B)

Enters the standard numbers for the second class required for an S_{11} 1-port calibration. (For predefined cal kits, this is SHORT (for the 7 mm) or SHORTS (for the type-N) .)

S11C (SPECS11C)

Enters the standard numbers for the third class required for an S₁₁ 1-port calibration. (For predefined kits, this is LOAD.)

SPECIFY: S22A (SPECS22A)

Enters the standard numbers for the first class required for an S₂₂ 1-port calibration. (For predefined cal kits, this is OPEN (for the 7 mm) or OPENS (for the type-N).)

S22B (SPECS22B)

Enters the standard numbers for the second class required for an S₂₂ 1-port calibration. (For predefined cal kits, this is SHORT (for the 7 mm) or SHORTS (for the type-N).)

S22C (SPECS22C)

Enters the standard numbers for the third class required for an S₂₂ 1-port calibration. (For predefined kits, this is LOAD.)

SPECIFY: FWD. TRANS. (SPECFWDT)

Enters the standard numbers for the forward transmission (THRU) calibration. (For predefined kits, this is THRU.)

REV. TRANS (SPECREVT)

Enters the standard numbers for the reverse transmission (THRU) calibration. (For predefined kits, this is THRU.)

FWD. MATCH (SPECFWDM)

Enters the standard numbers for the forward match (THRU) calibration. (For predefined kits, this is THRU.)

REV. MATCH (SPECREVM)

Enters the standard numbers for the reverse match (THRU) calibration. (For predefined kits, this is THRU.)

RESPONSE (SPECRESP)

Enters the standard numbers for a response calibration. This calibration corrects for frequency response in either reflection or transmission measurements (depending on the parameter being measured when a calibration is performed). (For predefined kits, the standard is either OPEN or SHORT for reflection measurements or THRU for transmission measurements.)

RESPONSE & ISO'N (SPECRESI)

Enters the standard numbers for a response and isolation calibration. This calibration corrects for frequency response and directivity in reflection measurements or frequency response and isolation in transmission measurements.

CLASS DONE (SPEC'D) (CLAD)

Completes the class assignment and stores it.

Note

The letter menu is described in the **Display** key section. See "Letter Menu."

LABEL CLASS**LABEL CLASS**

Displays softkeys that give the class a meaningful label for future reference. These labels become softkey labels during a measurement calibration. A label can be up to ten characters long.

LABEL: S11A (LABES11A)

Displays the *letter menu* to define the label for the first class required for an S_{11} 1-port calibration.

S11B (LABES11B)

Displays the *letter menu* to define the label for the second class required for an S_{11} 1-port calibration.

S11C (LABES11C)

Displays the *letter menu* to define the label for the third class required for an S_{11} 1-port calibration.

LABEL: S22A (LABES22A)

Displays the *letter menu* to define the label for the first class required for an S_{22} 1-port calibration.

S22B (LABES22B)

Displays the *letter menu* to define the label for the second class required for an S_{22} 1-port calibration.

S22C (LABES22C)

Displays the *letter menu* to define the label for the third class required for an S_{22} 1-port calibration.

LABEL: FWD: TRANS. (LABEFWDT)

Displays the *letter menu* to define the label for the forward transmission (THRU) calibration.

REV. TRANS. (LABEREVT)

Displays the *letter menu* to define the label for the reverse transmission (THRU) calibration.

FWD MATCH (LABEFWDM)

Displays the *letter menu* to define the label for the forward match (THRU) calibration.

REV MATCH (LABEREVM)

Displays the *letter menu* to define the label for the reverse match (THRU) calibration.

RESPONSE (LABERESP)

Displays the *letter menu* to define the label for the response calibration.

RESPONSE & ISO'N (LABERESI)

Displays the *letter menu* to define the label for the response and isolation calibration.

LABEL DONE

Completes the procedure to define labels and store them.

LABEL CAL KIT

LABEL KIT (LABK)

Displays the *letter menu* to define a label for a new calibration kit. This label appears in the **CAL KIT** softkey label in the correction menu and the **MODIFY** label in the select cal kit menu. It is saved with calibration data.

KIT DONE (MODIFIED) (KITD)

Completes the procedure to define user cal kit.

Standard, Type, Coefficient, and Class
A standard is a specific, well-defined physical device used to determine systematic errors.
A standard type is one of five basic types that define the form or structure of the model to be used with that standard (for example, SHORT or LOAD).
Standard coefficients are numerical characteristics of the standards used in the model selected.
A standard class is a grouping of one or more standards that determine which standards are used in a particular calibration procedure.

For more information on Modifying calibration Kits
See "Modifying Calibration Kits" in Chapter 12

Specify offset menu Network Analyzer

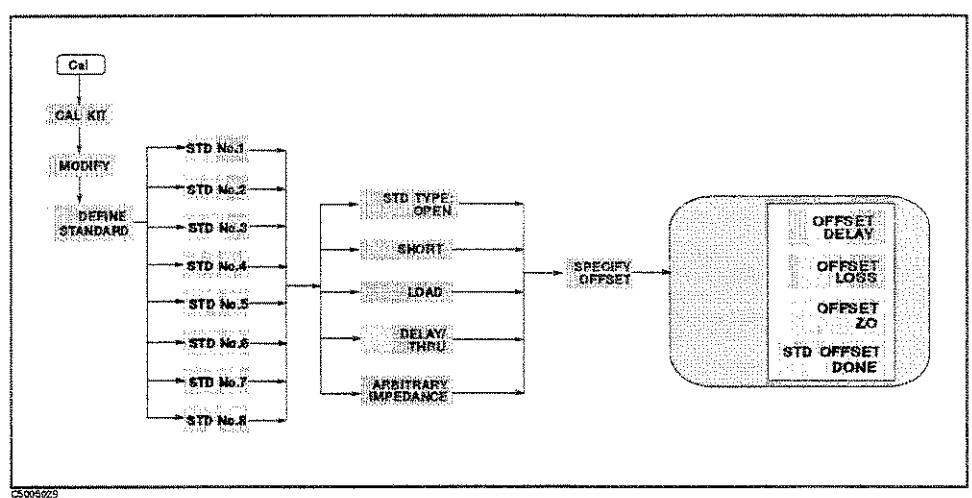

Figure 5-31. Specify Offset Menu

OFFSET DELAY

OFFSET DELAY

Specifies the one-way electrical delay from the measurement (reference) plane to the standard in seconds (s). (In a transmission standard, offset delay is the delay from plane to plane.) Delay can be calculated from the precise physical length of the offset, the permittivity constant of the medium, and the speed of light.

OFFSET LOSS

OFFSET LOSS

Specifies energy loss, due to skin effect, along a one-way length of coaxial cable offset. The value of loss is entered as ohms/nanosecond (or Giga ohms/second) at 1 GHz.

CHARACTERISTIC IMPEDANCE

OFFSET Z0 (OFSZ)

Specifies the characteristic impedance of the coaxial cable offset.

Note



This is not the impedance of the standard itself.

STD OFFSET DONE

Completes procedure to specify offset value of standard.

Standard Type menu
Network Analyzer

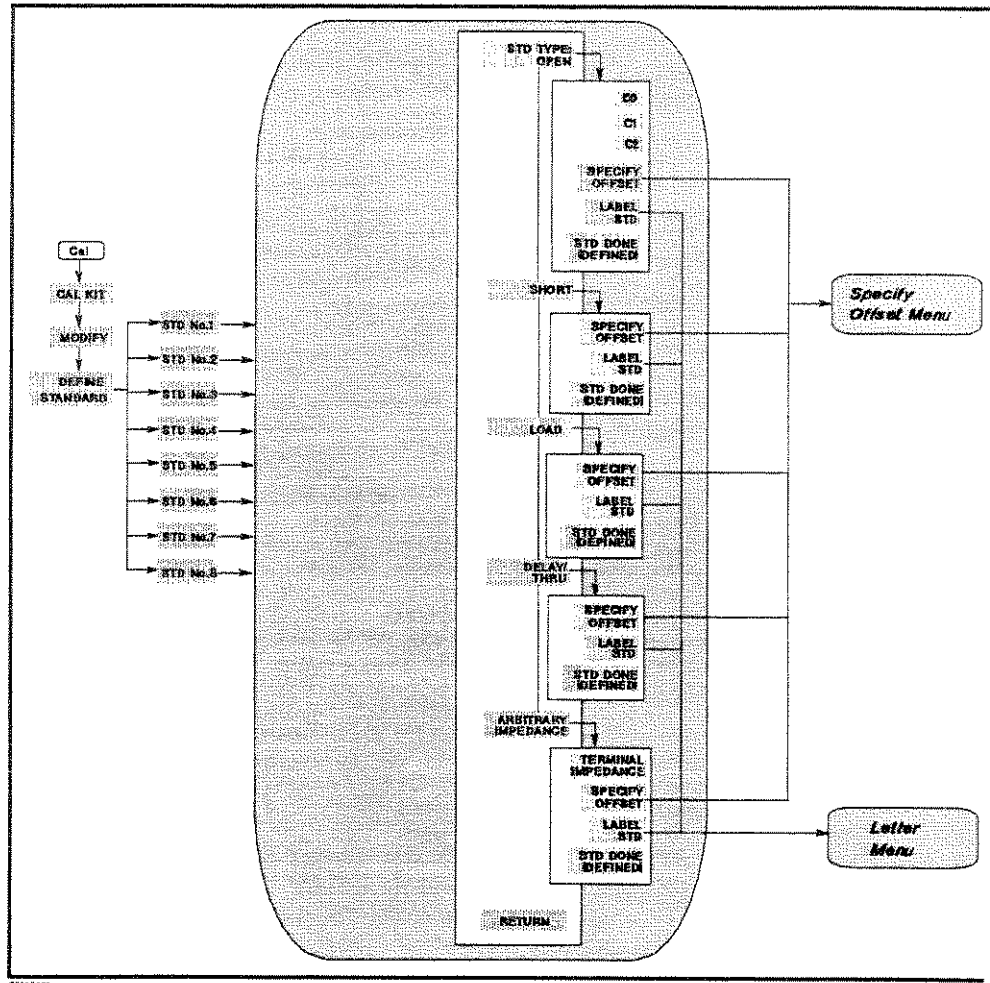

Figure 5-32. Standard Type Menu

OPEN **STD TYPE: OPEN (STDT OPEN)**

Defines the standard type as an OPEN (used for calibrating reflection measurements). OPENs are assigned a terminal impedance of infinite ohms (but delay and loss offsets can still be added). Pressing this key also displays a menu for defining the OPEN (including its capacitance).

Capacitance model for OPEN termination

As a reflection standard, an OPEN offers the advantage of broadband frequency coverage. However, an OPEN rarely has perfect reflection characteristics because fringing (capacitance) effects cause phase shifts that vary with frequency. This can be observed when measuring an OPEN termination after calibration (an arc in the lower right circumference of the Smith chart indicates capacitive reactance). These effects are impossible to eliminate. However, the calibration kit models include the OPEN termination capacitance at all frequencies for compatible calibration kits. The capacitance model is a second order polynomial (squared term), as a function of frequency, where the polynomial coefficients are user-definable. The capacitance model equation is:

$$C = C_0 + C_1 \times F + C_2 \times F^2$$

where F is the measurement frequency.

The terms in the equation are defined using the specify open menu.

C0 (C0)

Enters the C_0 term, which is the constant term of the quadratic equation and is scaled by 10^{-15} Farads.

C1 (C1)

Enters the C_1 term, expressed in F/Hz (Farads/Hz) and scaled by 10^{-27} .

C2 (C2)

Enters the C_2 term, expressed in F/Hz² and scaled by 10^{-36} .

SHORT

SHORT (STDT SHOR)

Defines the standard type as a SHORT, for calibrating reflection measurements. SHORTs are assigned a terminal impedance of 0Ω . However, delay and loss offsets can still be added.

LOAD

LOAD (STDT LOAD)

Defines the standard type as a LOAD (termination). LOADs are assigned a terminal impedance equal to the system characteristic impedance Z_0 . However, delay and loss offsets can still be added. If the LOAD impedance is not Z_0 , use the arbitrary impedance standard definition.

DELAY/THRU

DELAY/THRU (STDT DELA)

Defines the standard type as a transmission line of specified length, for calibrating transmission measurements.

ARBITRARY IMPEDANCE

ARBITRARY IMPEDANCE (STDT ARBI)

Defines the standard type to be a LOAD with an arbitrary impedance (different from system Z_0).

TERMINAL IMPEDANCE (TERI)

Specifies the (arbitrary) impedance of the standard in ohms.

SPECIFY OFFSET

Displays the *specify offset menu* that defines offsets in delay, loss, and standard impedance (Z_0) for each standard type.

LABEL STANDARD

LABEL STD (LABS)

Displays the *letter menu* to define a label for each standard.

STD DONE (DEFINED) (STDD)

Terminates the standard definition. Press this after each standard is defined (including offsets).

Calibration menu

Spectrum Analyzer

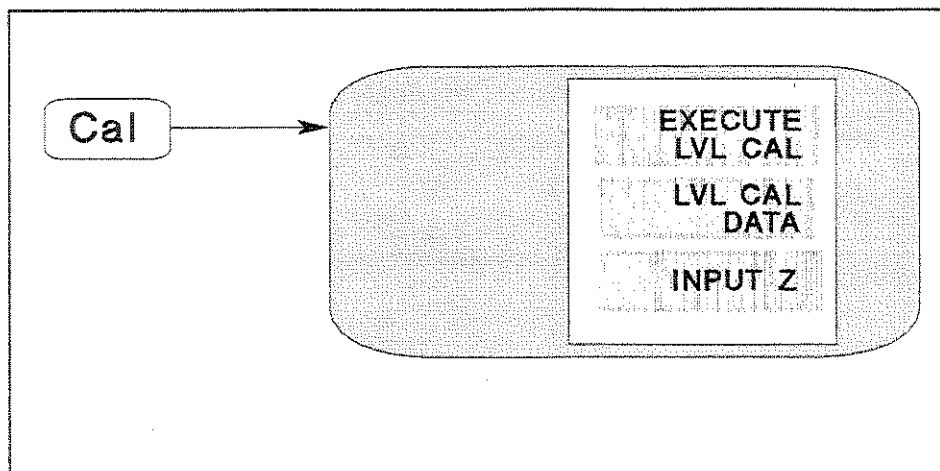

0509020

Figure 5-33. Calibration Menu for Spectrum Analyzer

LEVEL CAL

EXECUTE LVL CAL (LVLCAL)

Measures the CAL OUT signal (20 MHz, -20 dBm) at the input port selected by the *input port menu* accessed using **(Meas)** (automatically sets the level cal data). After executing this function, the instrument state is returned to the state that existed before executing

EXECUTE LVL CAL and cor is displayed at the left on the screen. If the CAL OUT signal is not correctly injected to the input port or if the analyzer is not set to measure the CAL OUT signal, the level cal data is automatically set to 0.

LVL CAL DATA (LVCDDT)

Set **LVL CAL DATA** to the level cal data (adds an offset value to the measured value).

INPUT IMPEDANCE

INPUT Z (INPZ)

Set the input impedance to either 50 Ω or 75 Ω .

The sweep type must be the linear frequency sweep when the analyzer measures the CAL OUT

The analyzer is not allowed to measure the cal out in the list sweep. If you press **LVL CAL DATA** in the list sweep, an error occurs and an error message is displayed.

Level Cal data can be set to each input port independently

The level cal can be performed at input R, A, or B as well as input S. When the input port is changed, the analyzer automatically selects the level cal data that is set when the input port is selected.

Sweep Block

The sweep block keys and associated menus provide control of the sweep, trigger, and source functions. The following list shows the functions controlled by each key in the sweep block.

Sweep	Controlling sweep time Selecting Sweep type Editing table for list sweep Selecting sampling mode for zero span (spectrum analyzer only) Selecting channel coupling (network analyzer only)
Source	Controlling RF output signal source Setting CW frequency for power sweep Controlling attenuator of an S-parameter testset (network analyzer only)
Trigger	Selecting trigger mode Selecting trigger source Selecting external trigger signal Selecting event caused by trigger Restarting measurement
Start	Setting start value of sweep parameter
Stop	Setting start value of sweep parameter
Center	Setting center value of sweep parameter
Span	Setting span of sweep parameter

The HP-IB programming command is shown in parenthesis following the key or softkey. Characters following the program code separated by a space are parameters of the command.

For example:

- ON|OFF shows that either ON or OFF can be used as a parameter. COUC ON|OFF means COUC ON or COUC OFF.
- [1-7] shows that numerical 1, 2, 3, 4, 5, 6, and 7 can be used as a parameter. SMKR [1-7] ON means SMKR 1 ON, SMKR 2 ON, SMKR 3 ON, SMKR 4 ON, SMKR 5 ON, SMKR 6 ON, and SMKR 7 ON.

For more information on HP-IB commands, see the *HP 4396B HP-IB Command Reference*.

Sweep

Sweep

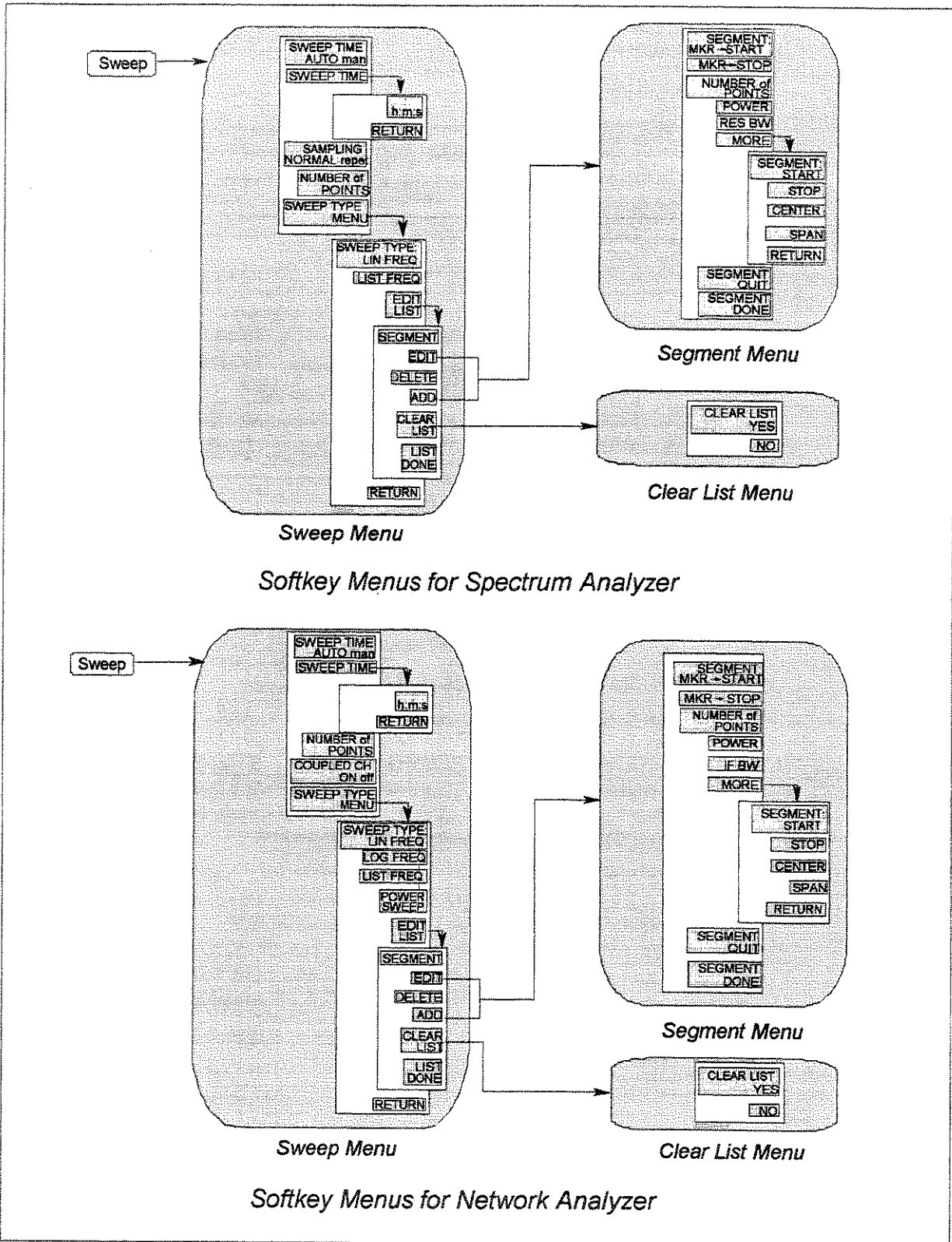

Figure 6-1. Softkey Menus Accessed from the **Sweep** Key

Sweep menu

Network Analyzer

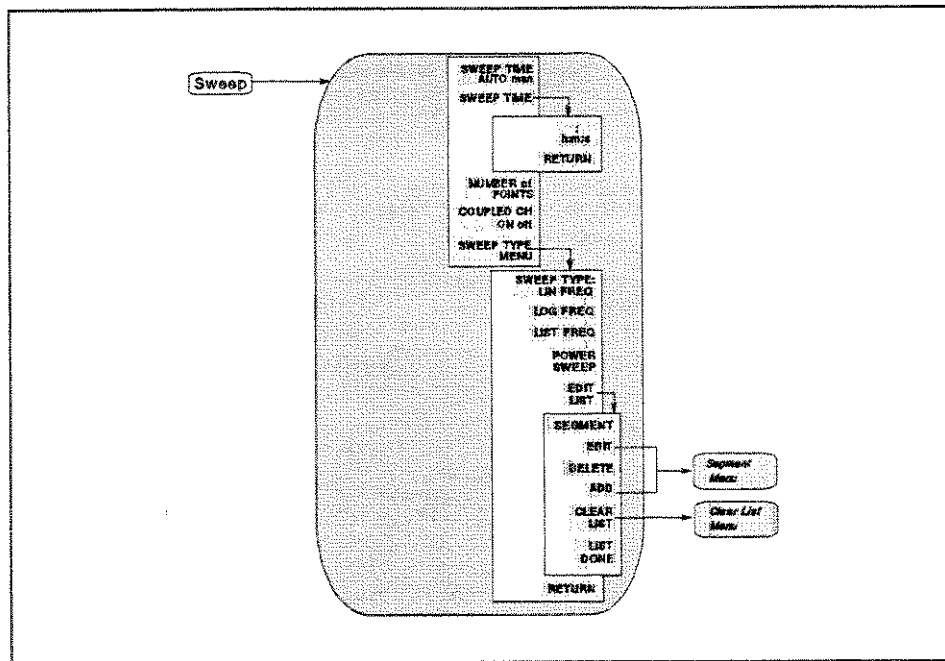

Figure 6-2. Sweep Menu for Network Analyzer

SWEEP TIME

SWEEP TIME AUTO man (SWETAUTO ON|OFF)

Toggles between automatic and manual sweep time. The automatic sweep time selects the optimum sweep time automatically.

SWEEP TIME (SWET)

Activates the sweep time function and displays the **:h:m:s** softkey.

:h:m:s

Enters ":" for the manual sweep time entry.

DISPLAY POINTS

NUMBER of POINTS (POIN)

Sets the number of data points per sweep. Using fewer points allows a faster sweep time but the displayed trace shows less horizontal detail. Using more points gives greater data density and improved trace resolution, but slows the sweep.

In list frequency sweep, the number of points displayed is the total number of frequency points for the defined list.

CHANNEL COUPLING

COUPLED CH ON off (COUC ON|OFF)

Toggles channel coupling of the sweep parameter values. With **COUPLED CH ON** (the preset condition), both channels have the same sweep parameter values (the inactive channel takes on the sweep parameter values of the active channel). If the channel's analyzer modes are different, the channels cannot be coupled.

SWEEP TYPE MENU (SWPT LIN|LOG|LIST|POWE)

Displays the *sweep type menu*. Using the softkeys on this menu, one of the following four sweep types can be selected for the network analyzer mode:

LINEAR SWEEP	SWEEP TYPE: LIN FREQ	Linear frequency sweep mode.
LOG SWEEP	LOG FREQ	Logarithmic frequency sweep mode. The source is stepped in logarithmic increments and the data is displayed on a logarithmic graticule.
LIST SWEEP	LIST FREQ	Frequency list mode. If the list is not defined, this softkey performs no function.
POWER SWEEP	POWER SWEEP	Power sweep mode. Used to characterize power-sensitive DUTs. In this mode, power is swept at a single frequency from a start power value to a stop power value. Values are selected using the START and STOP keys and the entry block.

LIST TABLE **EDIT LIST** (EDITLIST)

Displays the following softkeys to define or modify the frequency sweep list:

SEGMENT

Determines a segment on the list to be modified. Enter the number of a segment in the list, or use the step keys to scroll the pointer ">" at the left to the required segment number. The indicated segment can then be edited or deleted.

EDIT (SEDI)

Provides the *segment menu for network analyzer*. The segment indicated by the pointer ">" at the left can be modified.

DELETE (SDEL)

Deletes the segment indicated by the pointer ">".

ADD (SADD)

Adds a new segment to be defined with the *segment menu for network analyzer*. If the list is empty, a default segment is added and the edit segment menu is displayed so it can be modified. If the list is not empty, the segment indicated by the pointer ">" is copied and the edit segment menu is displayed.

CLEAR LIST (CLEL)

Displays the *clear list menu*.

LIST DONE (EDITDONE)

Defines the frequency sweep list and returns to the sweep type menu.

Note



For information on how to make list table, see Chapter 6 of the *HP 4396B Task Reference*.

Sweep

Sweep menu
Spectrum Analyzer

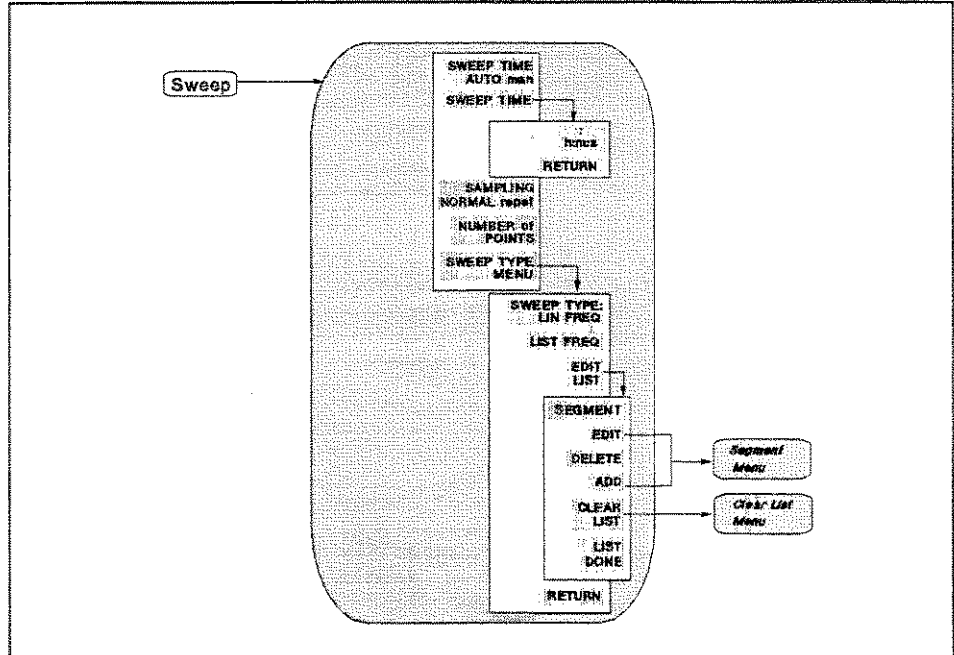

Figure 6-3. Sweep Menu for Spectrum Analyzer

SWEEP TIME

SWEEP TIME AUTO man (SWETAUTO)

Toggles between automatic and manual sweep time. The automatic sweep time selects the optimum sweep time automatically.

SWEEP TIME (SWET)

Activates the sweep time function and displays the **:h:m:s** softkey. The sweep time value can not be changed in the stepped FFT mode ($RBW \leq 3$ kHz).

:h:m:s

Enters “:” for the manual sweep time entry.

Sweep time can be set to a faster value than the AUTO mode setting

The sweep time AUTO mode sets the fastest sweep time with the maximum number of points (NOP). When the SPAN/RBW ratio is less than a certain value (about 200 through 400), the spectrum analyzer can measure the signal with a smaller NOP than the maximum NOP. In this case, when sweep time is reduced to less than the AUTO mode setting, NOP is automatically decreased. (Note that NOP of the spectrum analyzer cannot be changed directly.) Entering zero for the sweep time sets the fastest sweep time with fewest NOP because zero is rounded to the smallest value in the available range.

SAMPLING

SAMPLING NORMAL repet (REPTSMP OFF | ON)

Toggles between normal and repetitive sampling mode for zero span. When sampling is selected to repetitive mode, % will be displayed next to the SWP (sweep time).

Zero Span is required for the repetitive sampling mode

The sampling mode can be set to repetitive mode only when the instrument state meets the following conditions:

- Analyzer Type : Spectrum
- Sweep Type : Linear Sweep
- SPAN : 0
- Trigger Source : External or Video

If the instrument state does not meet these conditions, the sampling mode cannot be changed to the repetitive mode and a caution is displayed.

Normal Sampling and Repetitive Sampling

The normal sampling rate is 25 μ s. (this means that the analyzer needs 25 μ s interval between each measurement point). Since the repetitive sampling rate is equivalently 0.5 μ s, the repetitive sampling may get faster signal.

Note

For more information on the repetitive sampling mode, see "Repetitive Sampling" in Chapter 12.

DISPLAY POINT

NUMBER of POINTS (POIN)

Displays the current number of data points (NOP) per sweep. You can not enter a value to NOP in the spectrum analyzer mode except for zero span mode and list frequency sweep. The analyzer automatically set NOP.

In the zero span mode, this softkey sets the number of data points per sweep.

In list frequency sweep, the number of points displayed is the total number of frequency points for the defined list.

SWEEP TYPE MENU

Displays the *sweep type menu*. Using the softkeys on this menu, one of the following two sweep types can be selected for spectrum analyzer mode

LINEAR SWEEP

SWEEP TYPE: LIN FREQ (SWPT LINF)

Activates a linear frequency sweep mode.

LIST SWEEP

LIST FREQ (SWPT LIST)

Activates the frequency list mode. If the list is not defined, this softkey performs no function.

LIST TABLE

EDIT LIST (EDITLIST)

Displays the following softkeys to define or modify the frequency sweep list.

SEGMENT

Determines a segment on the list to be modified. Enter the number of a segment in the list, or use the step keys to scroll the pointer ">" at the left to the required segment number. The indicated segment can then be edited or deleted.

EDIT (SEDI)

Displays the *segment menu for spectrum analyzer*. The segment indicated by the pointer ">" at the left can be modified.

DELETE (SDEL)

Deletes the segment indicated by the pointer ">".

ADD (SADD)

Adds a new segment to be defined with the *segment menu for spectrum analyzer*. If the list is empty, a default segment is added and the edit segment menu is displayed so it can be modified. If the list is not empty, the segment indicated by the pointer ">" is copied and the edit segment menu is displayed.

CLEAR LIST (CLEL)

Displays the *clear list menu*.

LIST DONE (EDITDONE)

Defines the frequency sweep list and returns to the sweep type menu.

Number of Points (NOP) is Automatically Changed in the Spectrum Analyzer Mode

The NOP of each segment can be set from 2 through 801 with a resolution of 1. However, the following conditions cause the NOP to automatically change to a value the analyzer can set.

- When the frequency step is too narrow and RBW is less than 10 kHz, NOP may automatically decrease.
- When the frequency step is too wide, NOP is automatically changed.

SPAN and NOP of each segment must meet the following condition:

$$\text{SPAN} \leq F_{\text{max}} \times (\text{NOP} - 1)$$

Where, F_{max} is a constant that depends on the resolution bandwidth. F_{max} is the maximum frequency step size. That is, it is the maximum SPAN size at NOP=2. The following table lists the values of F_{max} for each resolution bandwidth.

RBW (Hz)	F_{max} (Hz)	RBW (Hz)	F_{max} (Hz)
3 M	no limit	1 k	20.446 920 M
1 M	no limit	300	5.119 921 875 M
300 k	no limit	100	1.279 980 468 75 M
100 k	1.638 375 G	30	511.992 187 5 k
30 k	368.634 375 M	10	127.998 046 875 k
10 k	40.959 375 M	3	39.999 389 648 4 k
3 k	40.959 375 M	1	12.799 804 687 5 k

Note

For information on how to make list table, see Chapter 6 of the *HP 4396B Task Reference*.

Sweep

Clear list menu

Network Analyzer
Spectrum Analyzer

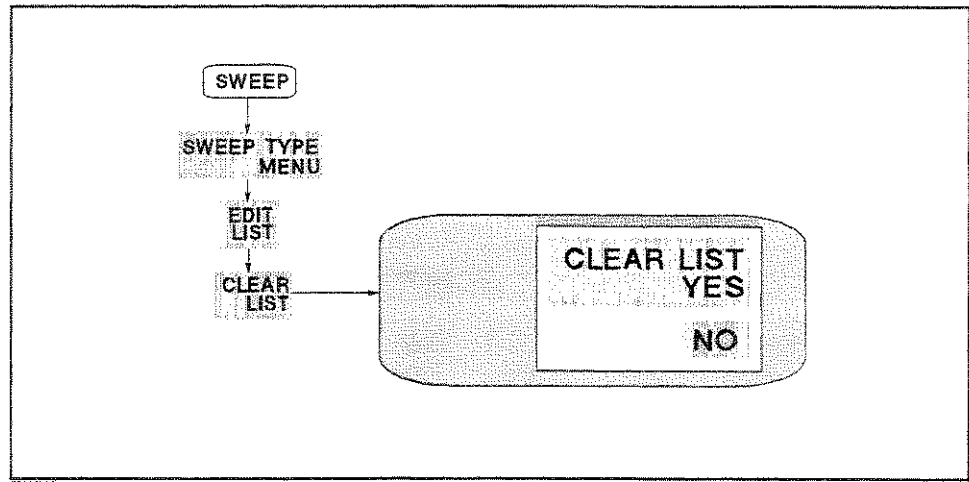

Figure 6-4. Clear List Menu

CLEAR LIST

CLEAR LIST YES

Clears the entire list.

NO

Cancels the task and returns to the edit list menu.

Segment menu

Network Analyzer

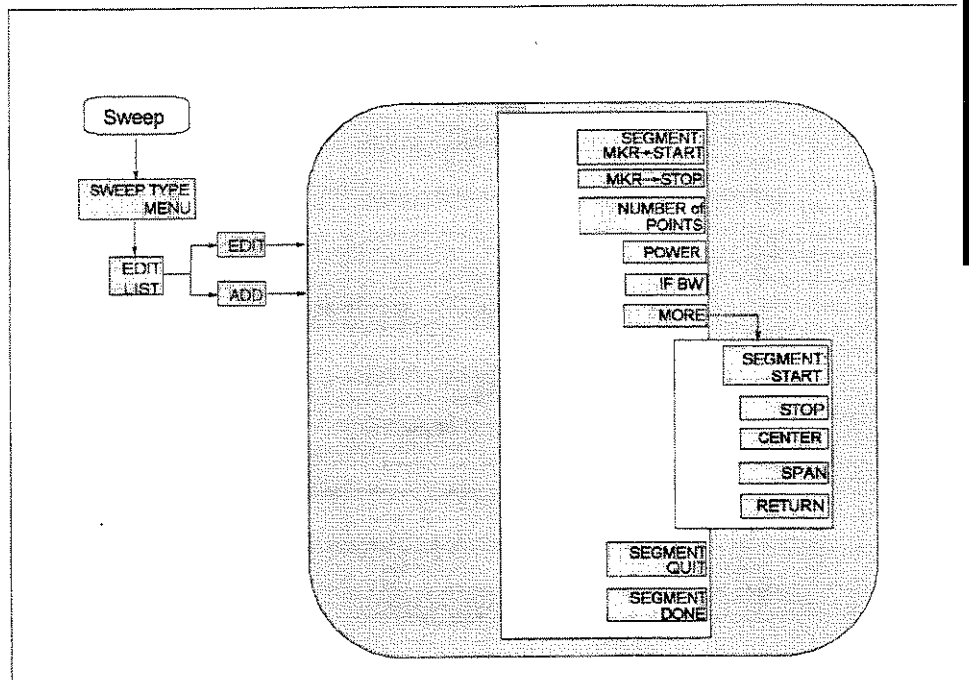

CB990004

Figure 6-5. Segment Menu for Network Analyzer

SEGMENT

SEGMENT: MKR->START (MKRSTAR)

Sets the sweep parameter start value to the sweep parameter value of the marker.

MKR->STOP (MKRSTOP)

Sets the sweep parameter stop value to the sweep parameter value of the marker.

NUMBER of POINTS (POIN)

Sets the number of points for the segment. The total number of points for all segments cannot exceed 801.

STEP SIZE (STPSIZE)

Specifies the segment in frequency steps instead of number of points. Changing the start frequency, stop frequency, span, or number of points may change the step size. Changing the step size may change the number of points and the stop frequency in the start/stop/step mode; or the frequency span in the center/span/step mode. In each case, the frequency span becomes a multiple of the step size.

POWER (POWER)

Sets the power level segment by segment. The allowable range is -70 dBm to $+20$ dBm.

IF BW (BW)

Sets the IF bandwidth segment by segment.

MORE

Displays the next page of the menu.

SEGMENT: START (STAR)

Sets the START frequency of a segment.

STOP (STOP)

Sets the STOP frequency of a segment.

CENTER (CENT)

Sets the CENTER frequency of a segment.

SPAN (SPAN)

Sets the frequency SPAN of a segment about a specified center frequency.

SEGMENT QUIT (SQUI)

Returns to the previous softkey menu without saving the modified segment.

SEGMENT DONE (SDON)

Saves the modified segment and returns to the previous softkey menu.

Segment menu Spectrum Analyzer

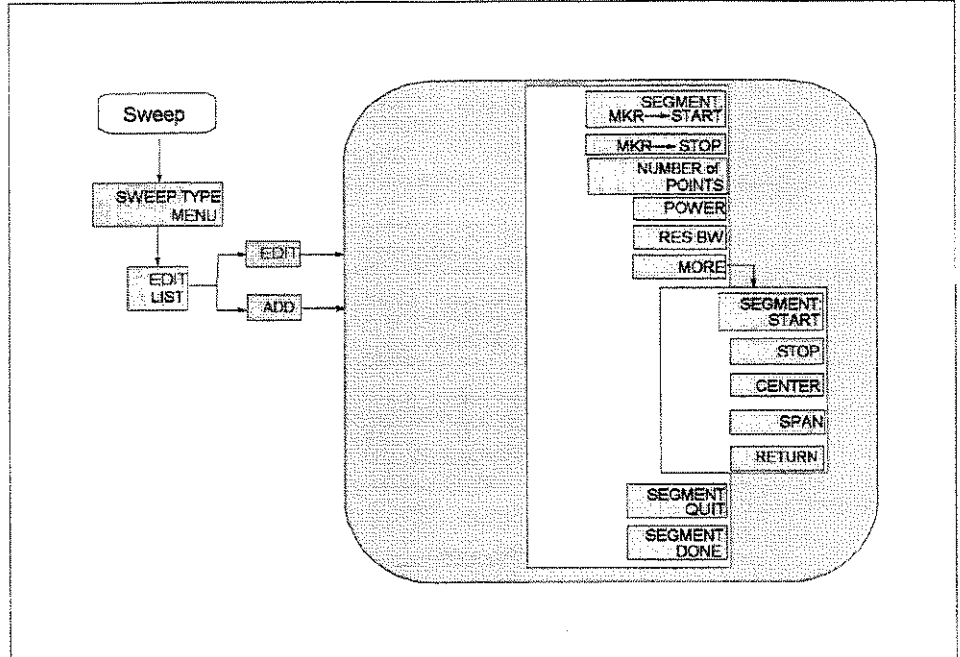

CB006003

Figure 6-6. Segment Menu for Spectrum Analyzer

SEGMENT: MKR->START (MKRSTAR)

Sets the sweep parameter start value to the sweep parameter value of the marker.

MKR->STOP (MKRSTOP)

Sets the sweep parameter stop value to the sweep parameter value of the marker.

POWER (POWER)

Sets the power level segment by segment. The allowable range is -70 dBm to +20 dBm.

RES BW (BW)

Sets the resolution bandwidth segment by segment.

MORE

Displays the next page of the menu.

SEGMENT: START (STAR)

Sets the START frequency of a segment.

STOP (STOP)

Sets the STOP frequency of a segment.

CENTER (CENT)

Sets the CENTER frequency of a segment.

SPAN (SPAN)

Sets the frequency SPAN of a segment about a specified center frequency.

SEGMENT QUIT (SQUI)

Returns to the previous softkey menu without saving the modified segment.

SEGMENT DONE (SDON)

Saves the modified segment and returns to the previous softkey menu.

Source

Source menu

Network Analyzer

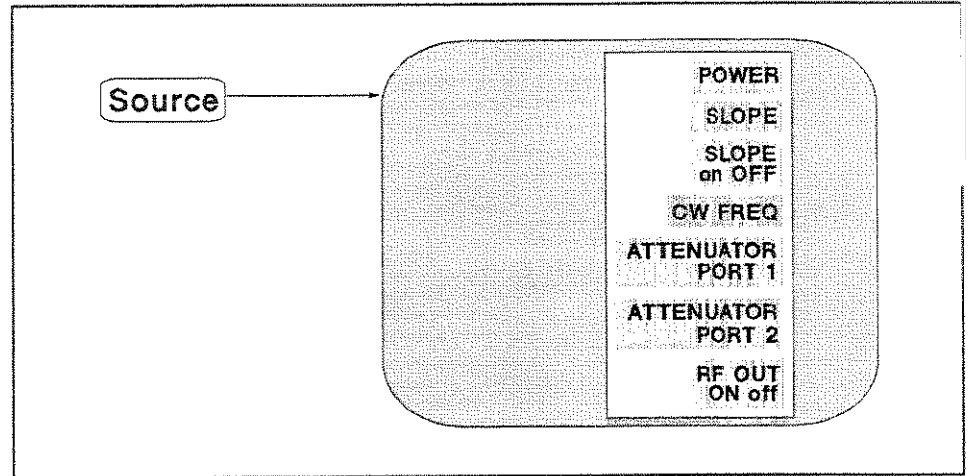

Figure 6-7. Source Menu for Network Analyzer

- POWER LEVEL** **POWER** (POWE)
 Activates the power level function.
- SLOPING** **SLOPE** (SLOPE)
 Compensates for power loss versus the frequency sweep by sloping the output power upwards proportionally to the frequency. Use this softkey to enter the power slope in dB per GHz of sweep. The slope must be set so that the maximum RF output level is in the range of the RF power source. That is, the RF output level at the stop frequency must be less than or equal to 20 dBm.
- SLOPE on OFF** (SLOP ON|OFF)
 Toggles the power slope function ON or OFF. With slope ON, the output power increases with frequency (starting at the selected power level).
- FREQUENCY FOR POWER SWEEP**
CW FREQ (CWFREQ)
 Sets the frequency for the power sweep.
- ATTENUATORS** **ATTENUATOR PORT 1** (ATTP1)
 Controls the attenuation at port 1 of an S-parameter test set that is connected to the analyzer. The attenuator range is 0 to 70 dB, controllable in 10 dB steps.
- The S-parameter test set must be connected to the analyzer by the test set interconnect cable for the attenuator control signal to be enabled. Note that no message is given if the test set is not connected or if it has no programmable attenuator.

ATTENUATOR PORT 2 (ATTP2)

Serves the same function as **ATTENUATOR PORT 1** for the attenuation at port 2 of the S-parameter test set.

The same attenuator value is used for both channels

The analyzer does not allow channel 1 and 2 to be set to different attenuator values. This is necessary because the same attenuator is used for both channels and is mechanically switched between them. To prevent excessive wear, continuous switching of the attenuator values between channels is not allowed.

RF OUT ON OFF (RFO ON|OFF)

Toggles the signal output on the RF OUT port ON or OFF. In the network analyzer mode, if the RF output is turned OFF, the status notation "P↓" is displayed.

Source

Source menu

Spectrum Analyzer

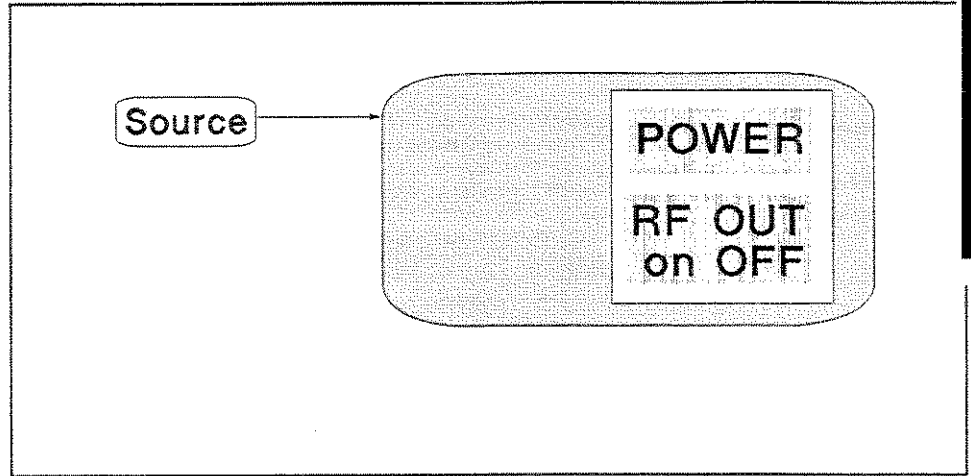

Figure 6-8. Source Menu for Spectrum Analyzer

POWER (POWE)

Activates the power level function and sets the RF output power level of the analyzer's internal source. The allowable range is -70 dBm to $+20$ dBm.

RF OUT on OFF (RFO ON|OFF)

Toggles the signal output on the RF OUT port ON or OFF. In the spectrum analyzer mode, if the RF output is turned ON, the status notation "P" is displayed.

The start frequency must be greater than or equal to 100 kHz when RF out is turned on at the spectrum analyzer because the frequency range of the RF output source starts at 100 kHz.

Be sure that the characteristics of the RF output source of the spectrum analyzer is different from ones of the network analyzer. (See Chapter 10 for additional information.)

Trigger menu

Network Analyzer
Spectrum Analyzer

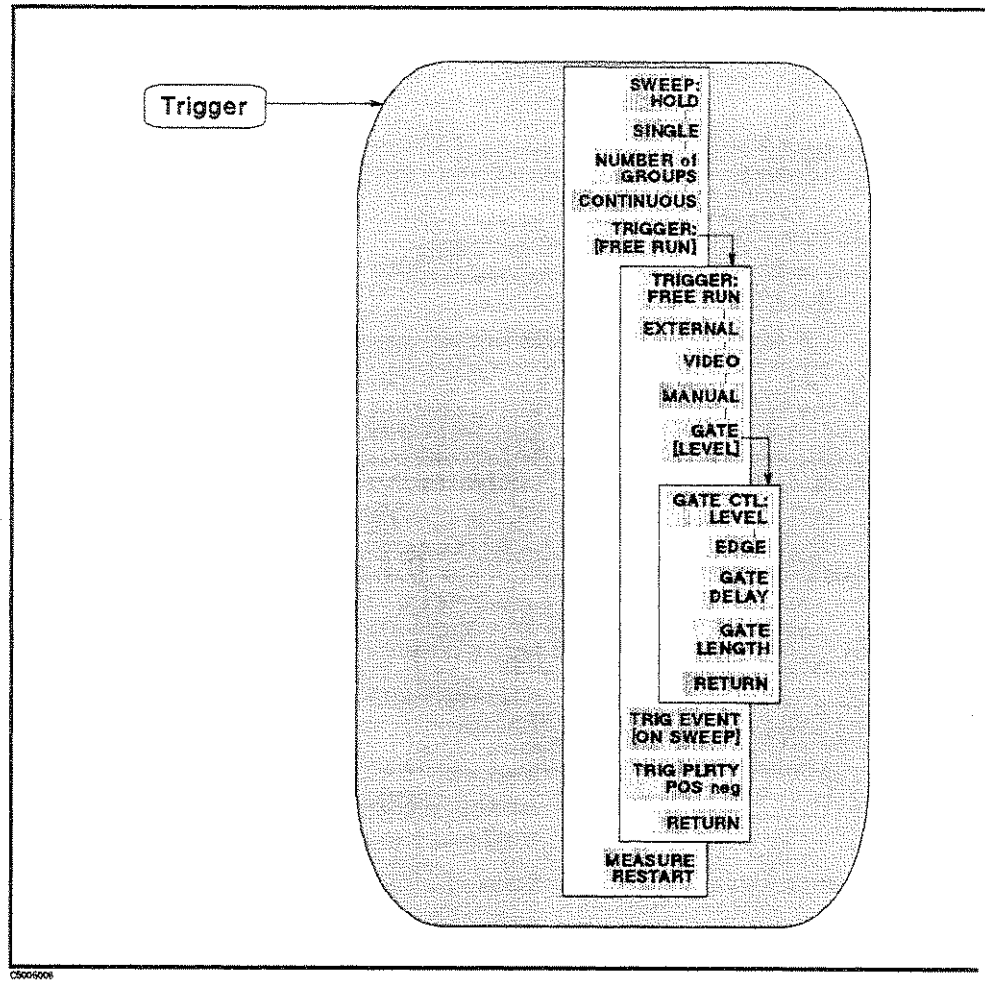

Figure 6-9. Trigger Menu

TRIGGER TYPE SWEEP: HOLD (HOLD)

Freezes the data trace on the display and the analyzer stops sweeping and taking data. The notation "Hld" is displayed at the left of the graticule. If the "*" indicator is on (at the left side of the display), trigger a new sweep by pressing SINGLE.

SINGLE (SING)

Makes one sweep of data and returns to the hold mode.

NUMBER of GROUPS (NUMG)

Triggers a user-specified number of sweeps and returns to the hold mode.

If averaging is ON, set the number of groups at least equal to the averaging factor selected to allow measurement of a fully averaged

trace. Entering the number of groups resets the averaging counter to 1.

CONTINUOUS (CONT)

Triggers the sweep automatically and continuously (the trace is updated with each sweep). This is the standard sweep mode.

TRIGGER SOURCE

TRIGGER: [FREE RUN] (TRGS INT|EXT|VID|MAN|GAT)

Displays the menu used to select the trigger source. The trigger source is common to both channels.

FREE RUN selects the internal trigger.

EXTERNAL selects the external trigger input from the BNC on the rear panel.

VIDEO Selects the video trigger (only for zero span mode in the spectrum analyzer mode). In other condition, the analyzer selects the internal trigger.

MANUAL Selects the manual trigger.

GATE [] Selects the external gate trigger and displays the softkeys used to specify the gate control mode (only for the spectrum analyzer mode). In zero span or the network analyzer mode, the analyzer selects the internal trigger. For more information on gate trigger, see "Gated Sweep" in Chapter 12. (Option 1D6 only)

The BUS trigger source can only be selected by using the HP-IB command TRGS BUS.

GATE TRIGGER

GATE [LEVEL] (GATCTL LEV|EDG)

Displays the menu used specify the gate trigger mode, the gate delay, and the gate length. To select the gate trigger mode, the following two softkeys are provided: (Option 1D6 only)

GATE CTL:LEVEL Selects the level gate trigger mode.

EDGE Selects the edge gate trigger mode.

GATE DELAY (GATDLY)

Sets the gate delay. (Option 1D6 only)

GATE LENGTH (GATLEN)

Sets the gate length. (Option 1D6 only)

Note



For more information on the gate trigger, see "Gated Sweep" in Chapter 12.

TRIGGER EVENT

TRIG EVENT [] (TRGEVE POIN|SWE)

Toggles the trigger event mode. This function is available in the network analyzer mode only. When in the spectrum analyzer mode, this softkey does not appear on the menu.

[ON POINT] Shows the analyzer triggers each data point in a sweep.

[ON SWEEP] Shows the analyzer triggers a sweep.

TRIGGER POLARITY

TRIG PLRTY POS neg (TRGP POS|NEG)

Selects the trigger signal polarity of an externally generated signal connected to the rear panel EXT TRIGGER input.

POS neg Shows the sweep is started with a low-to-high transition of a TTL signal.

pos NEG Shows the sweep is started with a high-to-low transition of a TTL signal.

RESTART SWEEP

MEASURE RESTART (REST)

Aborts the sweep in progress and then restarts the measurement. This can be used to update a measurement following an adjustment of the DUT or test signal source.

When a full two-port calibration is in use in the network analyzer mode, **MEASURE RESTART** initiates an update of both the forward and reverse S-parameter data.

If the analyzer is measuring a number of groups, the sweep counter is reset to 1. If averaging is ON, **MEASURE RESTART** resets the sweep-to-sweep averaging and is effectively the same as **AVERAGING RESTART**.

If the sweep trigger is in the **HOLD** mode, **MEASURE RESTART** executes a single sweep. If **DUAL CHAN** is ON (screen displays both measurement channels), **MEASURE RESTART** executes a single sweep of both channels even if **COUPLED CH** is OFF.

Start Stop

Start Stop (STAR, STOP)

These keys define the start value and the stop value of the frequency range or power range of the sweep parameter. When one of these keys is pressed, its function becomes the active function. The value is displayed in the active entry area and can be changed with the knob, step keys, or numeric keypad. Current sweep parameter values for the active channel are also displayed along the bottom of the graticule. In power sweep, the sweep parameter value is in dBm.

The range can be expressed as either start/stop or center/span.

Center

Center (CENT)

When this key is pressed, CENTER becomes the active function and the following menu is displayed:

Center menu

Network Analyzer
Spectrum Analyzer

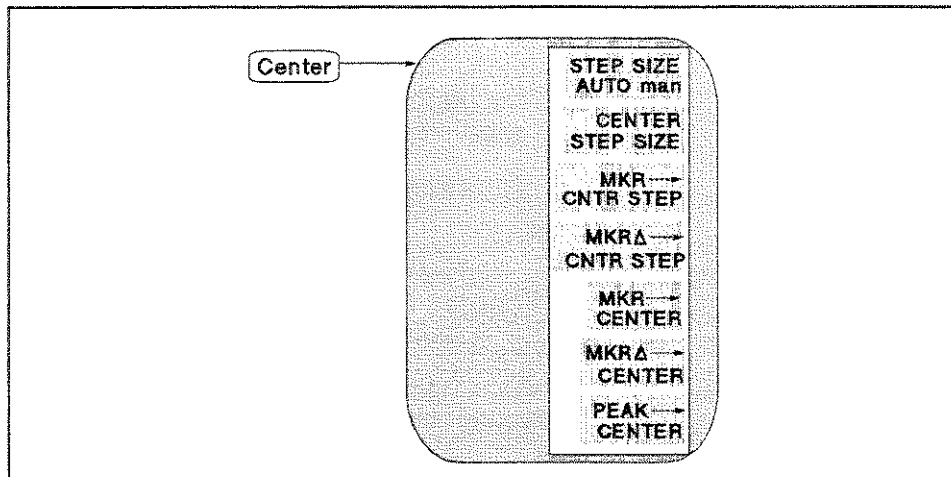

Figure 6-10. Center Menu

CENTER STEP SIZE **STEP SIZE AUTO man** (CNTSAUTO ON|OFF)

Toggles CENTER step policy.

AUTO Sets the step policy to be 1-2-5 step.

MAN Sets the step policy to linear step. (frequency sweep only)

CENTER STEP SIZE (CNTS)

Changes the step size for the center frequency function.

MKR -> CNTR STEP (MKRCSTE)

Changes the CENTER step size to the marker's sweep parameter value.

MKRA -> CNTR STEP (MKRDCSTE)

Changes the CENTER step size to the difference between the marker and the delta-marker values.

MKR -> CENTER (MKRCENT)

Changes the CENTER to the marker's sweep parameter value. When the **CROSS CHAN** under **Marker ->** is turned ON, the CENTER of the inactive channel is changed.

MKRSA -> CENTER (MKRDCENT)

Changes the CENTER to the difference between the marker and the delta-marker values.

PEAK→CENTER (PEAKCENT)

Searches for a peak using the marker and then changes the CENTER to the sweep parameter value of that peak.

Span

Span (SPAN)

When this key is pressed, SPAN becomes the active function and the following menu is displayed:

Span menu

Network Analyzer
Spectrum Analyzer

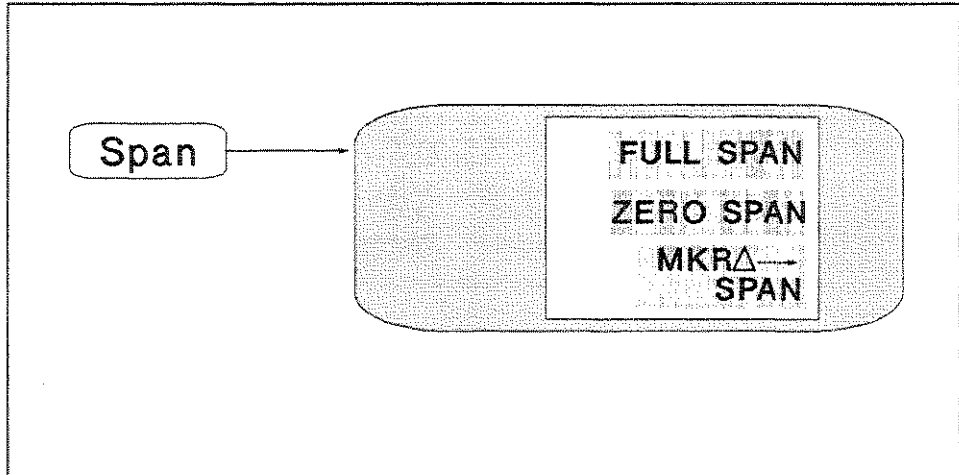

Figure 6-11. Span Menu

FULL SPAN **FULL SPAN (FULS)**

Sets the SPAN to the maximum range. The maximum range depends on the analyzer mode. The following table shows the maximum range of SPAN for each condition:

Analyzer Mode	Full Span
Spectrum Analyzer	1.8 GHz
Network Analyzer (frequency sweep)	1.7999 GHz
Network Analyzer (power sweep)	0 to 30 dB ¹

¹ The maximum range of SPAN in a power sweep depends on the CENTER value.

ZERO SPAN **ZERO SPAN (SPAN 0)**

Sets the SPAN to zero.

MKRΔ--SPAN (MKRDSPAN)

Changes the SPAN to the difference between the marker and the delta-marker values. When the **CROSS CHAN** under **Marker→** is turned ON, the SPAN of the inactive channel is changed.

(Start) and (Stop) key cannot be set zero span

Entering the same value into START and STOP never causes Zero-Span; In this case the SPAN value is set to minimum span value at the current setting, not zero.

Zero Span on the Spectrum Analyzer

Because the spectrum measurement on zero span requires some different settings, set the frequency span measurement as follows:

RBW must be \geq 10 kHz

When span is set to zero, RBW must be greater than or equal to 10 kHz. If the RBW is less than 10 kHz, it is automatically changed to 10 kHz when the span is set to 0.

Detection must be sample mode

When span is set to zero, the detection mode is automatically changed to the sample detection mode. When span is changed from zero to any value (except zero), the detection mode is automatically set to the positive peak mode.

Number of Points can be modified

When span is not zero, the number of points is automatically set properly and you cannot specify it. However, in zero span, you can specify the number of points. Changing the number of points causes changing sweep time. (The number of points is not changed when sweep time is changed.)

Marker Block

The marker block keys and associated menus provide control of the marker function. The following list shows the functions controlled by each key in the maker block.

Marker	Controlling the marker, sub-markers, and delta-marker Setting range for the marker search function
Marker⇒	Changing sweep parameter and amplitude values to the current marker's value Zooming traces
Search	Searching for peak, maximum, minimum, or point specified by amplitude value Setting peak definition Tracking signal (spectrum analyzer only) Searching bandwidth (network analyzer only)
Utility	Listing marker values Calculating statistics value Displaying marker time Calculating noise value (spectrum analyzer only) Selecting marker form for Smith, polar, and admittance chart

The HP-IB programming command is shown in parenthesis following the key or softkey. Characters following the program code separated by a space are parameters of the command.

For example:

- ON|OFF shows that either ON or OFF can be used as a parameter. COUC ON|OFF means COUC ON or COUC OFF.
- [1-7] shows that numerical 1, 2, 3, 4, 5, 6, and 7 can be used as a parameter. SUBMKR [1-7] ON means SUBMKR 1 ON, SUBMKR 2 ON, SUBMKR 3 ON, SUBMKR 4 ON, SUBMKR 5 ON, SUBMKR 6 ON, and SUBMKR 7 ON.

For more information on HP-IB commands, see the *HP 4396B HP-IB Command Reference*.

Marker

Marker (MKR ON)

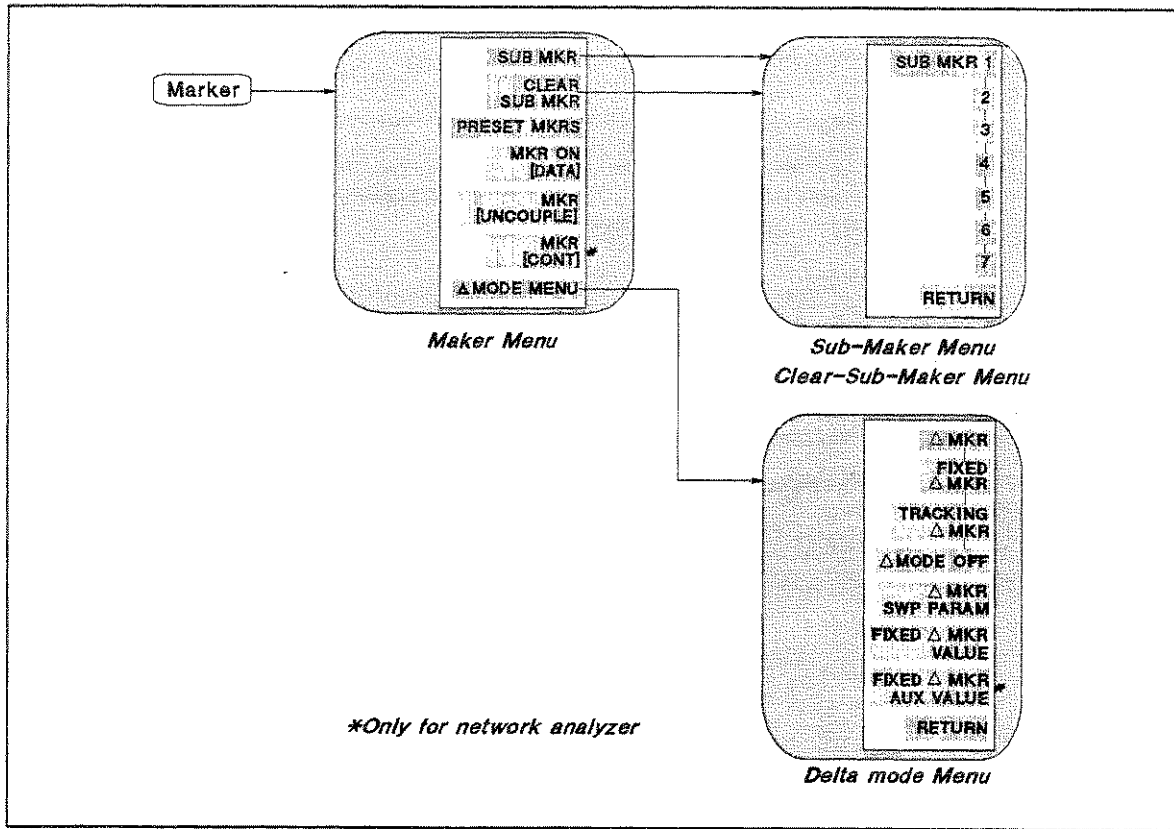

Figure 7-1. Softkey Menus Accessed from the **Marker** Key

Marker menu Network Analyzer Spectrum Analyzer

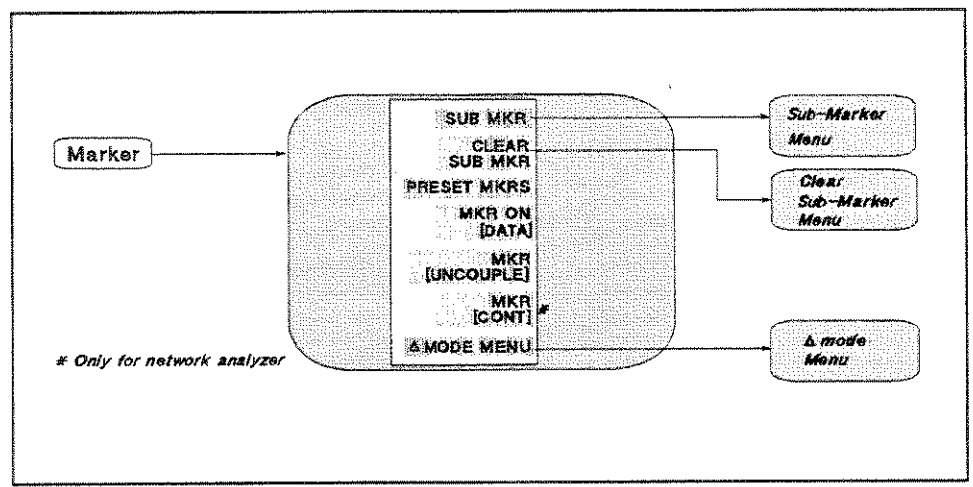

Figure 7-2. Marker Menu

SUB MKR (SKR [1-7] ON)

Displays the *sub-marker menu* that is used to turn on sub-markers.

CLEAR MARKERS

CLEAR SUB MKR (SMKR [1-7] OFF)

Displays the *sub-marker menu* that is used to turn off sub-markers.

PRESET MKRS (PRSMKRS)

Turns off all markers and cancels all setting of the marker functions.

MKR ON [] (MKRO DATA | MEMO)

Selects a trace from data or memory to be applied for the marker values.

[DATA] Shows that the data trace is selected.

[MEM] Shows that the memory trace is selected.

MARKER COUPLING

MKR [] (MKRCOUP OFF | ON)

Toggles between the coupled and uncoupled marker mode.

[COUPLE] Couples the marker sweep parameter values for the two display channels. Even if the sweep parameter is uncoupled and two sets of sweep parameter values are shown, the markers track the same sweep parameter values on each channel as long as they are within the displayed sweep parameter range.

[UNCOUPLE] Allows the marker sweep parameter values to be controlled independently on each channel.

CONTINUOUS

MKR [] (MKRCONT ON|OFF)

DISCRETE

Toggles between the continuous and discontinuous marker mode. This softkey appears only in the network analyzer mode. In the spectrum analyzer mode, the marker is always in the discontinuous mode.

[DISCRETE]

Places markers only on the measured trace points as determined by the sweep parameter settings.

[CONT]

Interpolates between the measured points to allow the markers to be placed at any point on the trace. Displayed marker values are also interpolated. This is the default marker mode (network analyzer only).

Δ MODE MENU

Displays the *delta mode menu* that is used to define the difference in values between the marker and a Δ marker.

Delta mode menu

Network Analyzer
Spectrum Analyzer

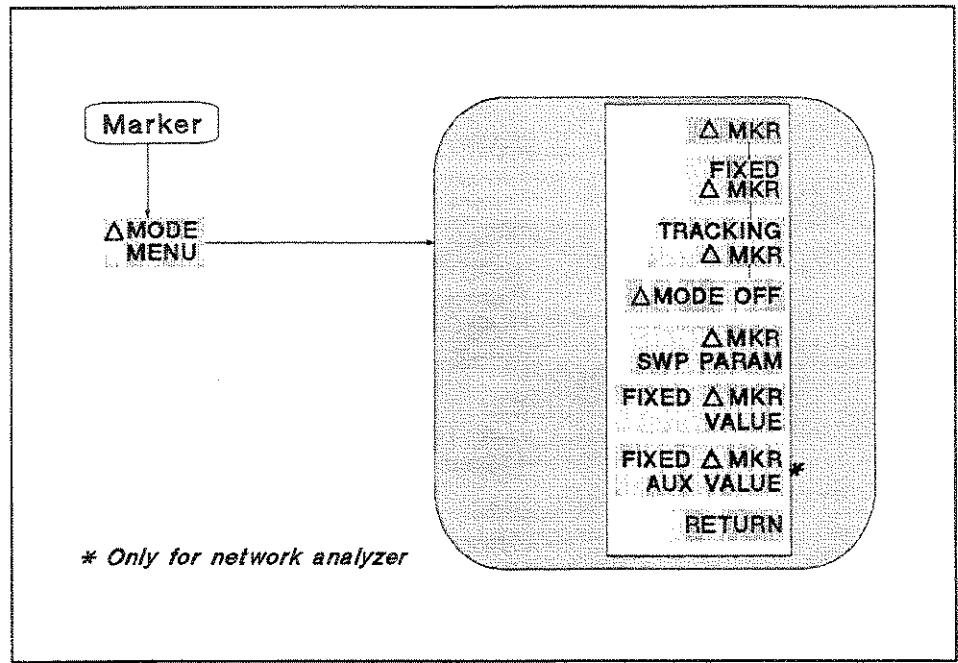

Figure 7-3. Delta Mode Menu

ΔMARKER **ΔMKR** (DMKR ON)
Puts the delta-maker on the current position of the marker.

FIXED ΔMKR (DMKR FIX)

Sets a user-specified fixed reference marker. The sweep parameter and amplitude values can be set arbitrarily and can be anywhere in the display area. Unlike other markers, the fixed Δmarker need not be on the trace. The fixed Δmarker is indicated by a small triangle Δ, and the marker sweep parameter and measurement values are shown relative to this point. The notation ΔMkr is displayed at the top right corner of the graticule.

TRACKING ΔMARKER **TRACKING ΔMKR** (DMKR TRAC)

Puts a Δmarker at the present active marker position and turns on the tracking Δmarker. The tracking Δmarker tracks the marker when the marker moves. In other words, the tracking Δmarker can be moved using the knob or a marker search function such as **SEARCH: PEAK**.

ΔMODE OFF (DMKR OFF)

Turns off the delta marker mode. Therefore, the values displayed for the marker and sub-marker are now absolute values.

FIXED Δ MARKER**AMKR SWP PARAM (DMKRPRM)**

Changes the sweep parameter value of the fixed Δ marker. Fixed Δ marker sweep parameter values can be different for the two channels if the channel markers are uncoupled.

FIXEDAMKR VALUE (DMKRVAL)

Changes the amplitude value of the fixed Δ marker. In a Cartesian format, this is the y-axis value. In a polar, Smith, or admittance chart format in the network analyzer mode, this is the first part (real part) of the complex data pair. It applies to a magnitude/phase marker, a real/imaginary marker, an R+jX marker, a G+jB marker, or an SWR/phase marker. Fixed Δ marker amplitude values are always uncoupled in the two channels.

FIXEDAMKR AUX VALUE (DMKRAUV)

Changes the auxiliary amplitude value of the fixed Δ marker (used only with a polar, Smith, or admittance format in the network analyzer mode). This is the second part (imaginary part) of a complex data pair. It applies to a magnitude/phase marker, a real/imaginary marker, an R+jX marker, a G+jB marker, or an SWR/phase marker. Fixed Δ marker auxiliary amplitude values are always uncoupled in the two channels. When the spectrum analyzer mode is selected, this softkey does not appear in this menu.

Sub-marker menu

Network Analyzer
Spectrum Analyzer

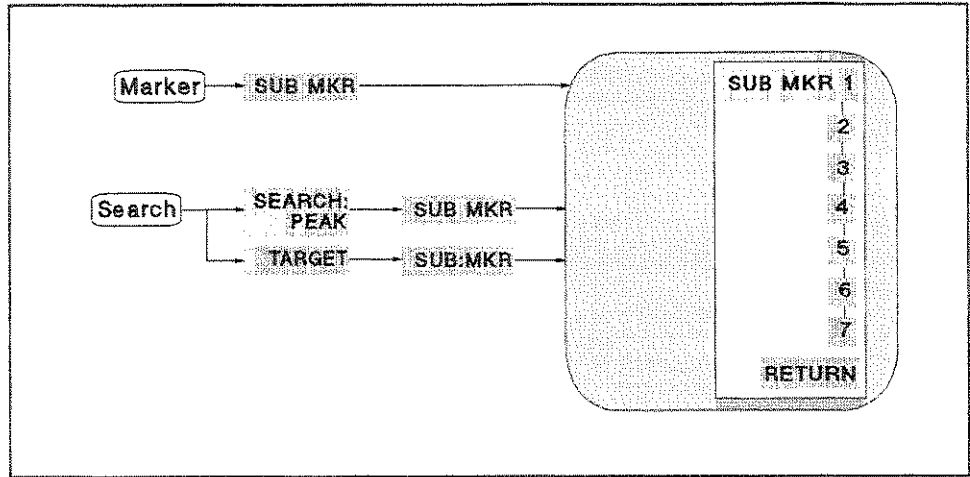

Figure 7-4. Sub-Marker Menu

- SUB-MARKER
- SUB MKR 1 (SMKR1 ON)
 - 2 (SMKR2 ON)
 - 3 (SMKR3 ON)
 - 4 (SMKR4 ON)
 - 5 (SMKR5 ON)
 - 6 (SMKR6 ON)
 - 7 (SMKR7 ON)

These keys put a sub-marker at the present marker position.

Marker

Clear Sub-marker menu

Network Analyzer
Spectrum Analyzer

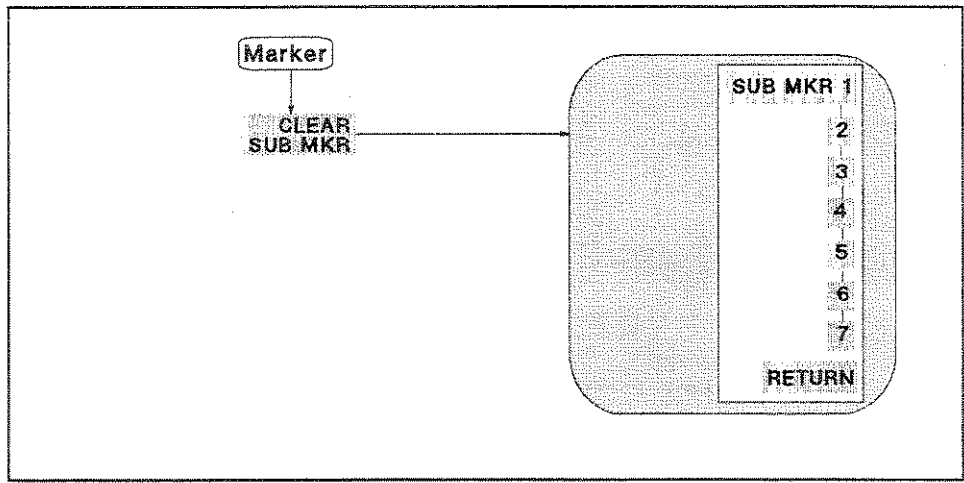

Figure 7-5. Clear Sub-Marker Menu

- CLEAR SUB-MARKER
- SUB MKR 1 (SMKR1 OFF)
 - 2 (SMKR2 OFF)
 - 3 (SMKR3 OFF)
 - 4 (SMKR4 OFF)
 - 5 (SMKR5 OFF)
 - 6 (SMKR6 OFF)
 - 7 (SMKR7 OFF)

These keys turn a sub-marker OFF.

Marker→

The **Marker →** key activates the marker (if it is not already active) and provides access to the marker→ functions. The marker→ functions change the sweep parameter and amplitude values to make them equal to the current marker or peak value. Use the knob or the numeric keypad to move the marker to the desired position on the trace and then press the appropriate softkey to set the specified parameters to that trace value. When the values are changed, the marker can again be moved within the range of the new parameters.

When the cross channel function is on, the active channel is changed to the inactive channel after a marker→ function is performed.

Marker→

Marker→ menu

Network Analyzer
Spectrum Analyzer

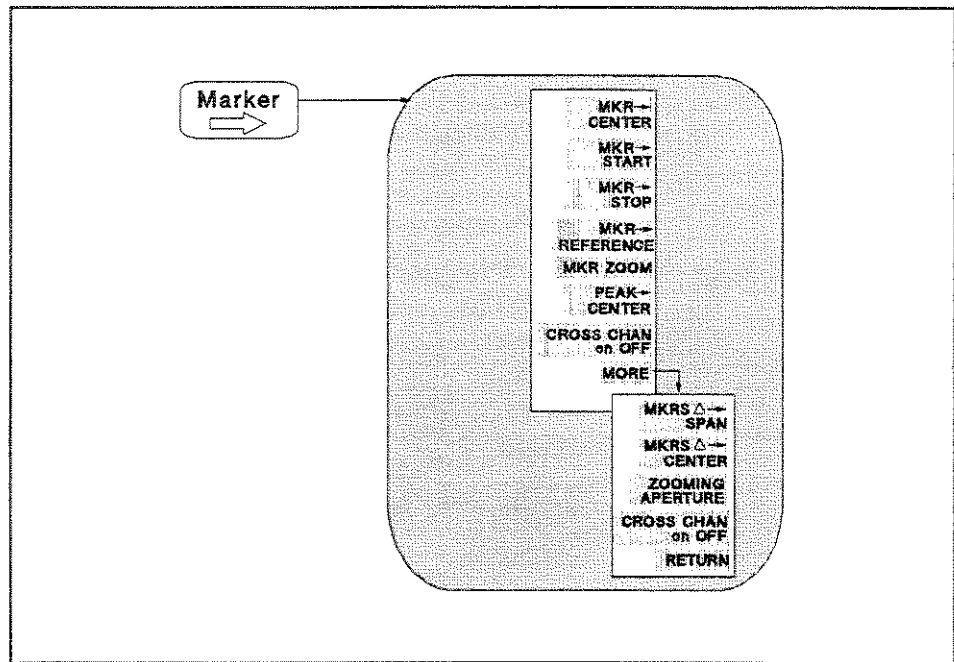

Figure 7-6. Marker→ Menu

MKR→ FUNCTION

MKR→CENTER (MKRCENT)

Changes the sweep parameter center value of the destination channel to the sweep parameter value of the marker and centers the new span about that value.

MKR→START (MKRSTAR)

Changes the sweep parameter start value of the destination channel to the sweep parameter value of the marker.

MKR→STOP (MKRSTOP)

Changes the sweep parameter stop value of the destination channel to the sweep parameter value of the marker.

MKR→REFERENCE (MKRREF)

Sets the reference value of the destination channel to the marker's amplitude value. The reference position is not changed even the network analyzer mode is selected. In the polar, Smith, or admittance chart format of the network analyzer mode, the full scale value at the outer circle is changed to the marker amplitude value.

MKR ZOOM (MKRZM)

Moves the marker to the center and changes the sweep parameter span value of the destination channel to the value specified by the zooming aperture. Performing this function is similar to zooming in on the signal in the center of the sweep range.

PEAK→CENTER (PEAKCENT)

Changes the sweep parameter center value of the destination channel to the sweep parameter value of the peak.

ZOOMING

ZOOMING APERTURE (ZMAPER)

Sets the zooming aperture value as a percentage of the span.

ΔMARKER→FUNCTION

MKRA→SPAN (MKRDSPAN)

Changes the sweep parameter span value of the destination channel to the difference value between the marker and Δmarker values.

MKRA→CENTER (MKRDCEM)

Changes the sweep parameter center value of the destination channel to the difference value between the marker and Δmarker values.

CROSS CHANNEL

CROSS CHAN on OFF (CRSC ON|OFF)

Selects the destination channel of the marker→ functions. When the cross channel is turned off, a marker → function changes the sweep parameter or the amplitude value of the active channel. When the cross channel is turned on, a marker → function changes the parameters of the inactive channel.

ON

Selects the current inactive channel as the destination channel.

OFF

Selects the current active channel as the destination channel.

The active channel is NOT changed to the destination channel after a marker → function is performed, even when the cross channel is turned on.

The cross channel can be turned on when the dual channel is turned on.

Search

Search

The **Search** key activates the marker (if it is not already active) and provides access to the marker search functions. The marker search functions can quickly search the trace for specified information.

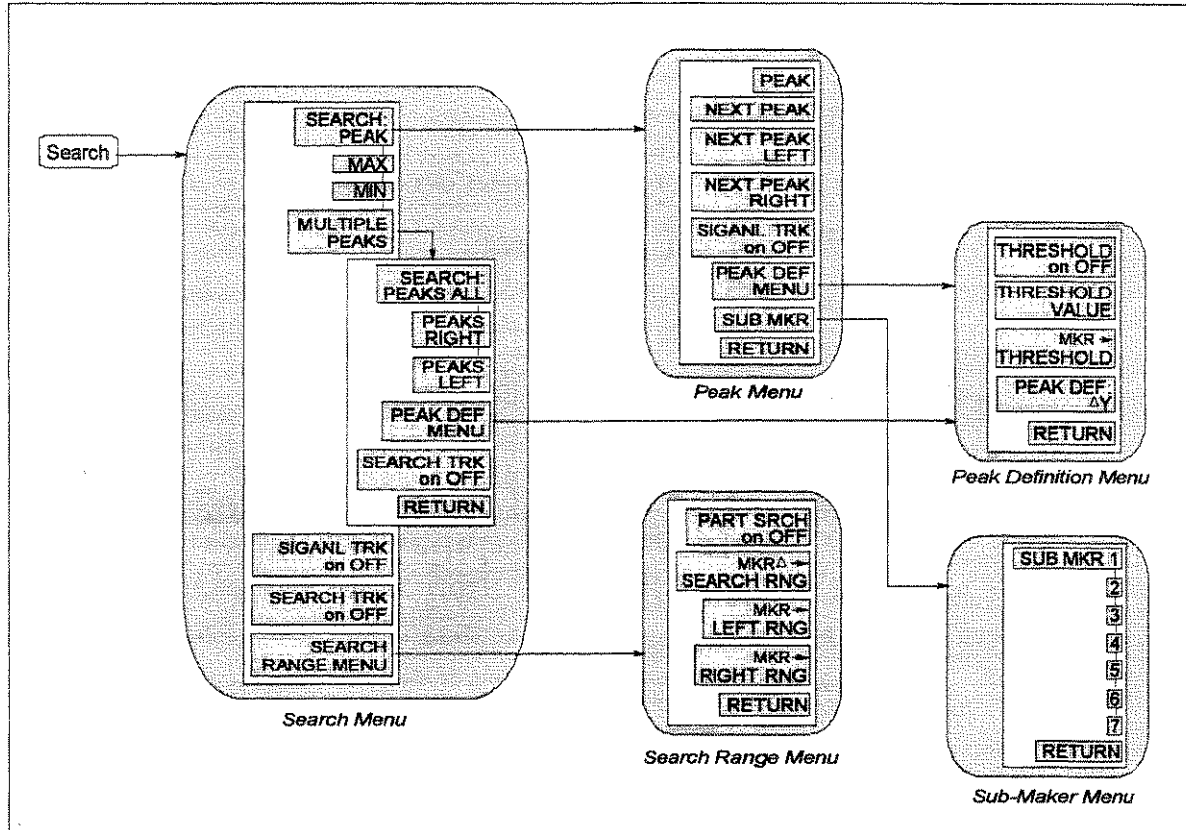

CB007018

Figure 7-7. Softkey Menus Accessed from the **Search** Key for the Network Analyzer

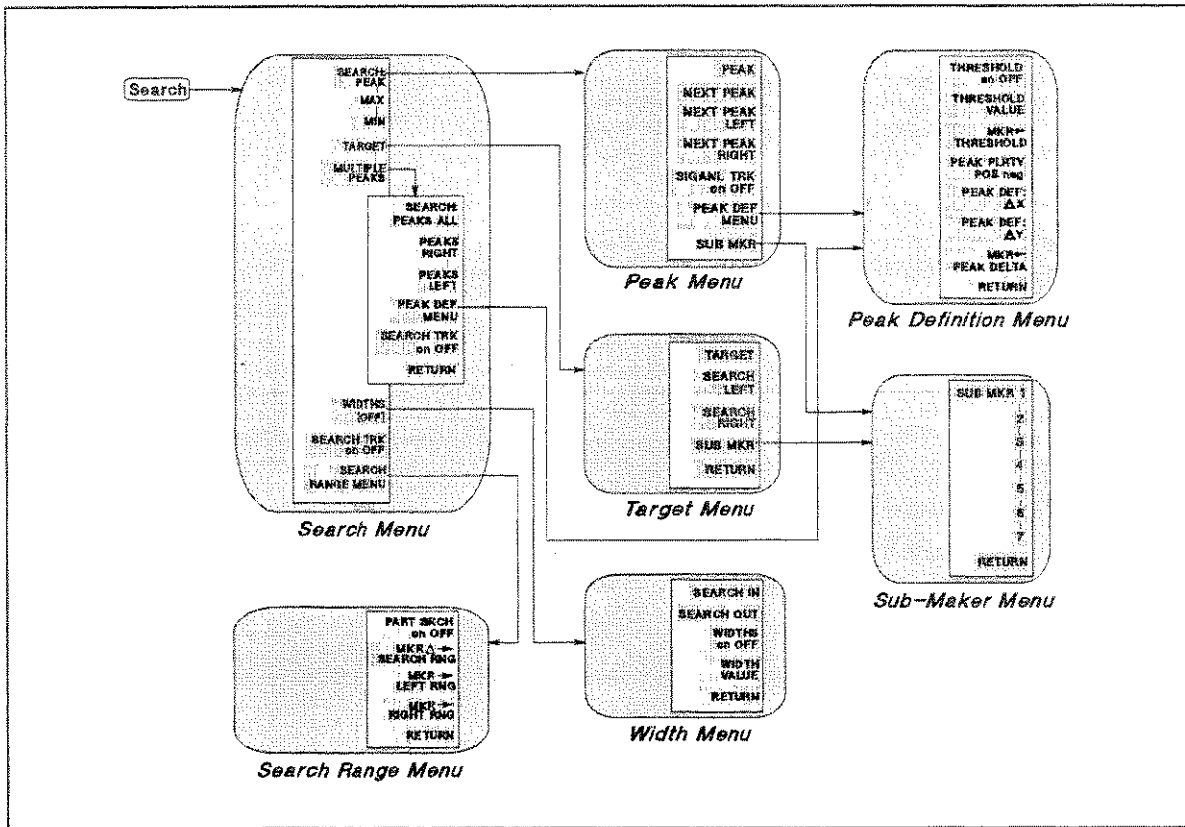

C5007016

Figure 7-8. Softkey Menus Accessed from the **Search** Key for the Spectrum Analyzer

Search

Search menu
Network Analyzer
Spectrum Analyzer

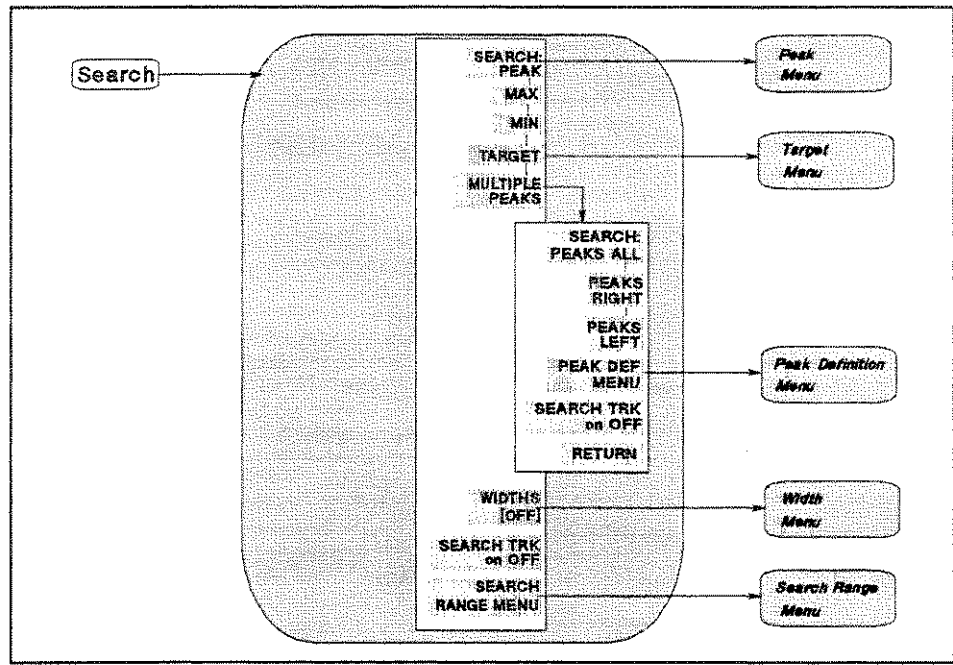

Figure 7-9. Search Menu for the Network Analyzer

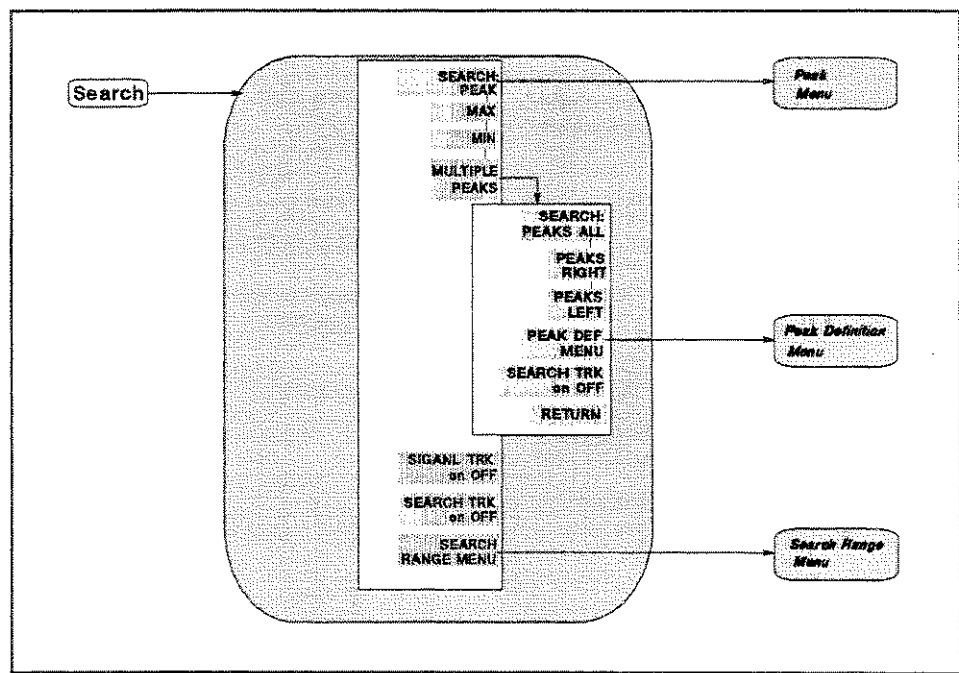

Figure 7-10. Search Menu for the Spectrum Analyzer

- PEAK SEARCH** **SEARCH: PEAK** (SEAM PEAK)
- Moves the marker to the maximum or minimum peak and displays the *peak menu* that is used to search for the next peak. The search function searches for a peak that meets the peak definition specified in the peak define menu. See the peak define menu for more information on peak definition.
- MAX SEARCH** **MAX** (SEAM MAX)
- Moves the marker to the maximum amplitude point on the trace.
- MIN SEARCH** **MIN** (SEAM MIN)
- Moves the marker to the minimum amplitude point on the trace.
- TARGET SEARCH** **TARGET** (SEAM TARG)
- Moves the marker to a specified target point on the trace and displays to the target menu that is used to search right and search left to resolve multiple solutions. This softkey appears in the network analyzer mode only.
- MULTIPLE PEAKS**
- Displays softkeys that are used to search multiple peaks.
- PEAK ALL** **SEARCH: PEAKS ALL** (SEAM PKSA)
- Searches for eight maximum or minimum peaks using the marker and the sub-markers. Each time **SEARCH: PEAKS ALL** is pressed, the marker moves to the maximum or minimum peak. The sub-markers move to the next peaks in the order of amplitude values of the peaks. If the number of peaks on the trace is less than eight, the sub-markers that cannot identify a peak are not turned on.
- PEAKS RIGHT** (SEAM PKSR)
- Searches to the right of the peak for the nearest seven peaks from the maximum or minimum peak. Each time **PEAKS RIGHT** is pressed, the marker moves to the maximum or minimum peak. The sub-markers move to the next peaks on the right of the marker position. The sub-markers start at the nearest peak from the marker position.
- PEAKS LEFT** (SEAM PKSL)
- Searches to the left of the peak for the nearest seven peaks from the maximum or minimum peak. Each time **PEAKS LEFT** is pressed, the marker moves to the maximum or minimum peak. The sub-markers move to the next peaks on the left of the marker position. The sub-markers start at the nearest peak from the marker position.
- PEAK DEF MENU**
- Displays the peak definition menu.

SEARCH TRACK

SEARCH TRK on OFF (TRACK ON|OFF)

Toggles the search tracking. This is used in conjunction with other search features to track the search of each new sweep.

ON Makes the analyzer search every new trace for the specified target value and puts the active marker on that point.

OFF When the target is found on the current sweep, it remains at the same sweep parameter value regardless of changes in trace amplitude values in subsequent sweeps.

WIDTH

WIDTHS [] (WIDT ON|OFF)

Displays the menu that is used to define the start and stop points for a bandwidth search in the network analyzer mode and to turn bandwidth search ON and OFF.

[OFF] Shows the bandwidth search is turned off.

[ON] Shows the bandwidth search is turned on.

WIDTHS [] is displayed in the network analyzer mode only. When the spectrum analyzer mode is selected, **SIGNAL TRK on OFF** is displayed in this position.

SIGNAL TRACK

SIGNAL TRK on OFF (SGTRK ON|OFF)

Toggles signal tracking on and off.

[ON] Moves the signal that is nearest to the marker to the center of the screen and keeps the signal there.

[OFF] Turns off the signal tracking.

SIGNAL TRK on OFF is displayed in the spectrum analyzer mode only. When the network analyzer mode is selected, **WIDTHS []** is displayed in this position.

Signal Tracking Limits
<p>Because signal tracking requires high speed throughput, the following limits apply when using this function:</p> <ul style="list-style-type: none"> ■ Signal tracking is available only in the spectrum analyzer mode. ■ Search tracking is not performed even if it is turned on. Search tracking starts when the signal tracking is turned off (if the search tracking is still turned on). ■ The peak definition of the marker search function is not affected during signal tracking. Signal tracking searches for the nearest positive peak from the marker. ■ Partial search range is not available during signal tracking is turned on.

When CROSS CHAN is turned on
<p>The signal tracking function searches the active channel for the signal and changes the CENTER value of the inactive channel.</p>

SEARCH RANGE MENU

Displays the search range menu.

Search

Peak menu

Network Analyzer
Spectrum Analyzer

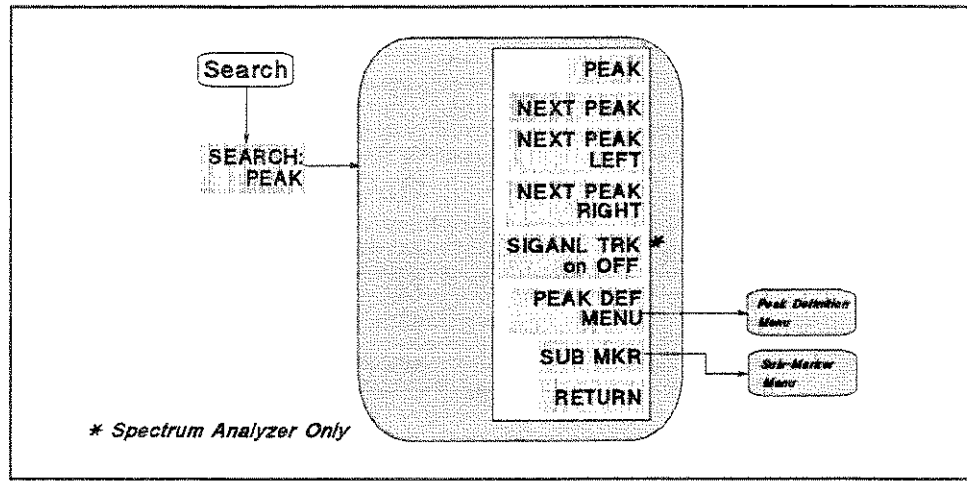

Figure 7-11. Peak Menu

PEAK (SEAM PEAK)

Moves the marker to the maximum or minimum peak.

NEXT PEAK **NEXT PEAK** (SEANPK)

Moves the marker to the next peak.

LEFT PEAK **NEXT PEAK LEFT** (SEANPKL)

Moves the marker to the peak on the left of the present marker position.

RIGHT PEAK **NEXT PEAK RIGHT** (SEANPKR)

Moves the marker to the peak on the right of the present marker position.

SIGNAL TRK on OFF (SGTRK ON|OFF)

Toggles signal tracking on and off. When the network analyzer mode is selected, this softkey does not appear in this menu.

PEAK DEF MENU

Displays the *peak definition menu*.

SUB MKR

Displays the *sub-marker menu* that is used to put a sub-marker at the marker position.

Target Menu

Network Analyzer

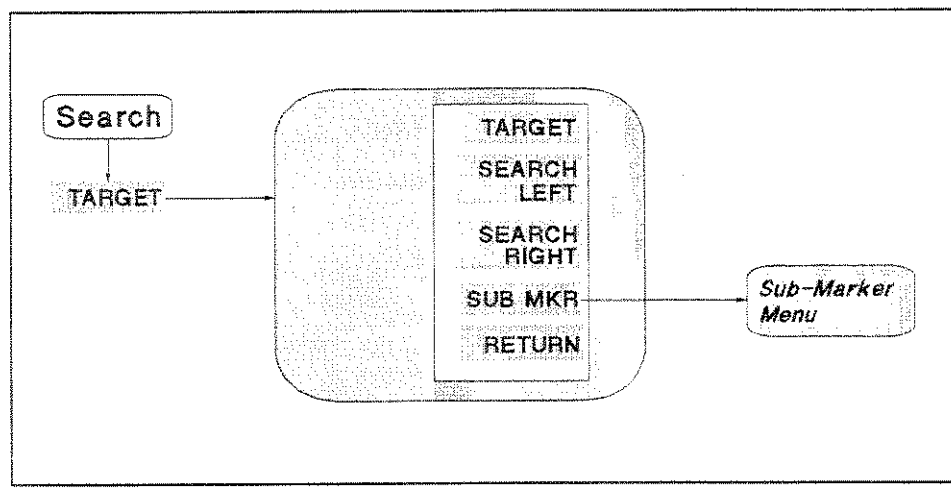

Figure 7-12. Target Menu

TARGET SEARCH

TARGET (SEATARG)

Makes the target value to the active function to enter a value and moves the marker to a specified target point on the trace.

The target value is in units appropriate to the current format. The default target value is -3 dB.

In delta marker mode, the target value is the value relative to the Δ marker. If no Δ marker is ON, the target value is an absolute value.

SEARCH LEFT (SEAL)

Searches the trace for the next occurrence of the target value to the left.

SEARCH RIGHT (SEAR)

Searches the trace for the next occurrence of the target value to the right.

SUB MKR

Displays the *sub-marker menu* that is used to put a sub-marker on the present marker position.

Widths Menu

Network Analyzer

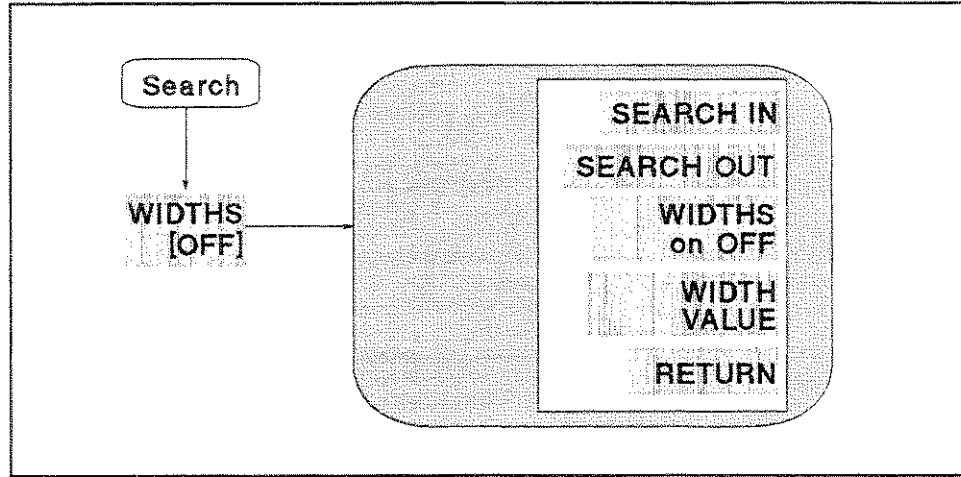

Figure 7-13. Widths Menu

WIDTH FUNCTION

SEARCH IN (WIDSIN)

Searches for the cutoff point on the trace that is within the current cutoff points.

SEARCH OUT (WIDSOUT)

This softkey searches for the cutoff point on the trace outside of the current cutoff points.

WIDTHS on OFF (WIDT ON|OFF)

Turns on the bandwidth search feature and calculates the center sweep parameter value, bandwidth, Q, insertion loss, and cutoff point deviation from the center of a bandpass or band reject shape on the trace. The amplitude value that defines the passband or reject band is set using the **WIDTH VALUE** softkey.

The Δ marker is automatically changed to the tracking Δ marker when **WIDTHS** is turned on. When **WIDTHS** is ON, the (normal) Δ marker cannot be selected.

WIDTH VALUE (WIDV)

Sets an amplitude parameter (for example, -3 dB) that defines the start and stop points for a bandwidth search. The bandwidth search feature analyzes a bandpass or band reject trace and calculates the center point, bandwidth, and Q (quality factor) for the specified bandwidth. Bandwidth units are in the units of the current format. When the tracking Δ marker or the fixed Δ marker is ON, the bandwidth value specified is the difference from the Δ marker.

In the expanded phase mode, this function searches for the two cutoff points whose values are "+ WIDTH VALUE" and "- WIDTH VALUE." For example, when the width value is 45° , the cutoff points' values are $\pm 45^\circ$.

Note



For more information on the width function, see “Width Function” in Chapter 12.

Peak definition menu
Network Analyzer

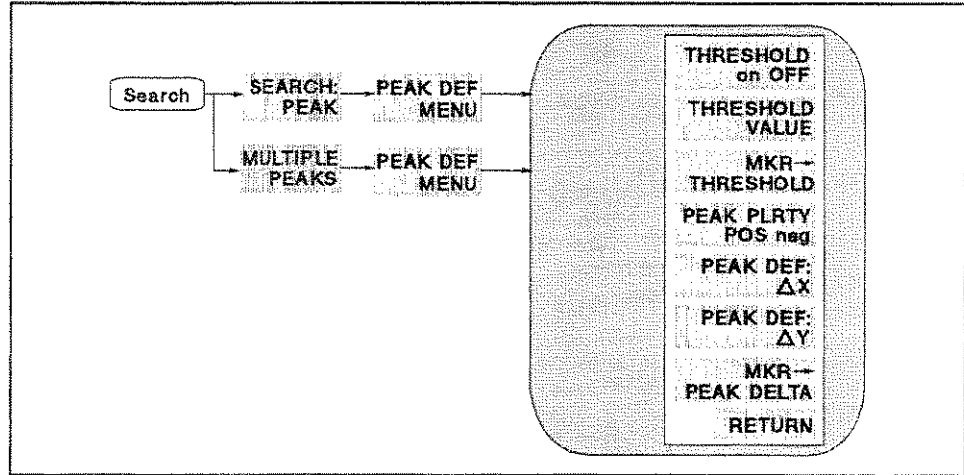

Figure 7-14. Peak Definition Menu for Network Analyzer

THRESHOLD **THRESHOLD on OFF** (PKTHRE ON|OFF)

Toggles the threshold on and off.

THRESHOLD VALUE (PKTHVAL)

Sets the threshold values.

MKR - THRESHOLD (MKRTHRE)

Changes the threshold value to the amplitude value of the present marker position.

PEAK POLARITY **PEAK PLRTY POS neg** (PKPOL POS|NEG)

Selects the peak polarity for the marker search functions.

POS Selects a positive peak

NEG Selects a negative peak

PEAK DELTA **PEAK DELTA: ΔX** (PKDLTX)

Sets the peak delta ΔX value that is used to define the peak.

PEAK DELTA: ΔY (PKDLTY)

Sets the peak delta ΔY value that is used to define the peak.

MKR - PEAK DELTA (MKRPKD)

Changes the peak delta value to the smaller value of the difference of amplitude values between the present maker position and both side display points of the marker.

Search Peak Function Definitions for Network Measurement	
Peak polarity	Detects either the positive or negative peak that is defined by PEAK PLRTY POS neg .
Threshold	Detects a peak whose amplitude value is greater than or equal to the threshold (even if the peak polarity is negative). Threshold is used in order to reject the noise floor.
Peak Delta	Detects a peak whose differences of amplitude values between the peak and both side display points of the peak are greater than or equal to the peak delta value specified by PEAK DELTA . The peak delta function is used to reject small peaks.

Note

For more information on peak definition, see “Peak Definition” in Chapter 12.

Search

Peak definition menu Spectrum Analyzer

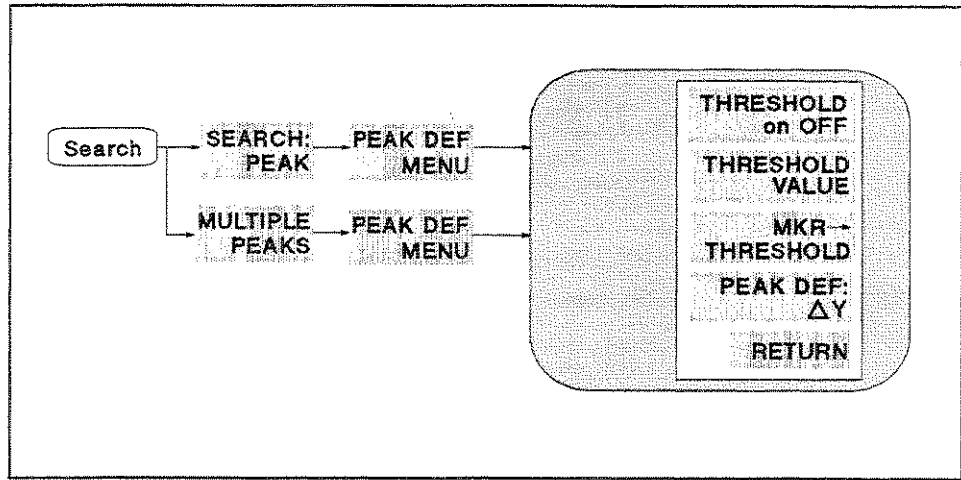

Figure 7-15. Peak Definition Menu for Spectrum Analyzer

THRESHOLD THRESHOLD on OFF (PKTHRE ON|OFF)

Toggles the threshold on and off.

THRESHOLD VALUE (PKTHVAL)

Sets the threshold values.

MKR -> THRESHOLD (MKRTHRE)

Changes the threshold value to the amplitude value of the present marker position.

PEAK DEF: ΔY (PKDLTY)

Sets the peak delta ΔY value that is used to define the peak.

Search Peak Function Definitions for Spectrum Measurement	
Threshold	Detects a peak whose amplitude value is greater than or equal to the threshold. Threshold is used in order to reject the noise floor.
Peak Delta	Detects a peak whose differences of amplitude values between the peak and both side local minimum points of the peak are greater than or equal to the peak delta value specified by <u>PEAK DELTA:Δ</u> . The peak delta function is used to reject small peaks.

Note



For more information on peak definition, see “Peak Definition” in Chapter 12.

Search range menu

Network Analyzer
Spectrum Analyzer

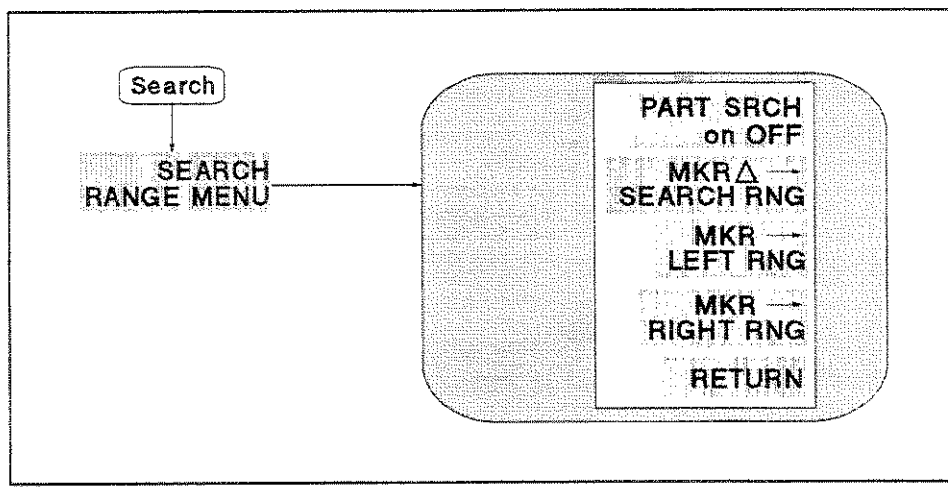

Figure 7-16. Search Range Menu

SEARCH RANGE

PART SRCH on OFF (PARSON|OFF)

Turns partial search ON or OFF. The search range is displayed by two small triangles, "Δ", at the bottom of the graticule. If no search range is defined, the search range is the entire trace.

MKRA → SEARCH RNG (SEARSTR)

Sets the partial search range to the range between the marker and Δmarker.

MKR → LEFT RNG (SEARSTRL)

Sets the left (lower) border of the partial search range at the current position of the marker.

MKR → RIGHT RNG (SEARSTRR)

Sets the right (higher) border of the partial search range at the current position of the marker.

Utility menu

Spectrum Analyzer

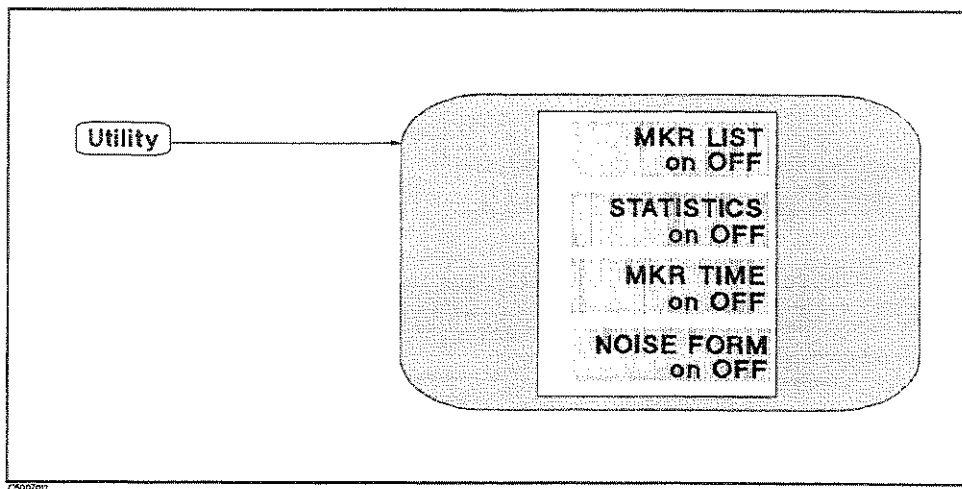

Figure 7-17. Utility Menu for Spectrum Analyzer

- MARKER LIST** **MKR LIST on OFF** (MKRL ON|OFF)
- Toggles the marker list function on and off. This lists the sweep parameter values and amplitude values of all markers. In Δ mode, this also lists Δ marker.
- STATISTICS** **STATISTICS on OFF** (MEASTAT ON|OFF)
- Calculates and displays the mean, standard deviation, and peak-to-peak values of the section of the displayed trace in the search range. If Partial Search is OFF, the statistics are calculated for the entire trace. The statistics are absolute values.
- MARKER TIME** **MKR TIME on OFF** (MKRTIME ON|OFF)
- Sets the x-axis units to time, (the start point is zero and the stop point is the value of the sweep time). The marker indicates the elapsed time since the sweep started. This function is useful for testing a DUT's time transition characteristics at a certain fixed frequency by setting the span to zero.
- NOISE FORM MARKER** **NOISE FORM on OFF** (MKRNOI ON|OFF)
- Toggles the noise marker on and off. This marker reads out the average noise level (referenced to a 1 Hz noise power bandwidth) at the marker position.
- Δ Marker reads out spectrum value even if the noise form is turned on.

Utility menu Network Analyzer

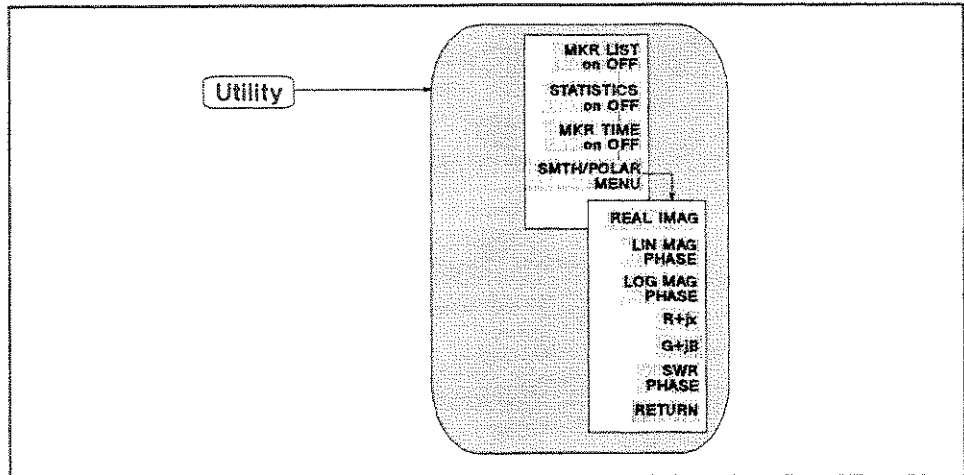

Figure 7-18. Utility Menu for Network Analyzer

MARKER LIST

MKR LIST on OFF (MKRL ON|OFF)

Toggles the marker list function on and off. This lists the sweep parameter values and amplitude values of all markers. In Δ mode, this also lists Δ marker.

STATISTICS

STATISTICS on OFF (MEASTAT ON|OFF)

Calculates and displays the mean, standard deviation, and peak-to-peak values of the section of the displayed trace in the search range. If Partial Search is OFF, the statistics are calculated for the entire trace. The statistics are absolute values.

For Polar, Smith and Admittance Chart Formats
The statistics are calculated using the absolute value of the complex value.

A Convenient Use of Statistics
The statistics function provides a convenient way to find the peak-to-peak value of passband ripple without searching separately for the maximum and minimum values.

MARKER TIME

MKR TIME on OFF (MKRTIME ON|OFF)

Sets the x-axis units to time, (the start point is zero and the stop point is the value of the sweep time). The marker indicates the elapsed time since the sweep started. This function is useful for testing a DUT's time transition characteristics at a certain fixed frequency by setting the span to zero.

SMITH/POLAR MENU

SMTH/POLAR MENU

Displays softkeys to select a form of complex marker value on Smith, polar, and admittance chart.

SMITH CHART

REAL IMAG (CIRF RI)

Displays the values of the marker on a Smith chart as a real and imaginary pair. The complex data is separated into its real and imaginary parts. The first marker value given is the real part ($= M \cos\theta$), and the second value is the imaginary part ($= M \sin\theta$), where $M =$ magnitude.

POLAR CHART

LIN MAG PHASE (CIRF LIN)

Displays a readout of the linear magnitude and the phase of the marker. Marker magnitude values are expressed in units and phase values in degrees.

ADMITTANCE CHART

LOG MAG PHASE (CIRF LOG)

Displays the logarithmic magnitude value and the phase of the marker. Magnitude values are expressed in dB and phase values in degrees.

R+jX (CIRF RX)

Converts the marker values into rectangular form. The complex impedance values of the active marker are displayed in terms of resistance, reactance, and equivalent capacitance or inductance.

The normalized impedance Z_0 for characteristic impedance other than 50Ω can be selected (see "Calibration menu Network Analyzer" in Chapter 5 for more information).

G+jB (CIRF GB)

Displays the complex admittance values of the marker in rectangular form. The marker values are displayed in terms of conductance (in Siemens), susceptance, and equivalent capacitance or inductance.

SWR PHASE (CIRF SWR)

Displays the SWR and phase of the marker. Magnitude values are expressed in dB and phase values in degrees.

Instrument State Block

The instrument state block keys and associated menus control channel-independent system functions. These include controller modes, analyzer addresses, real time clock, limit lines and limit testing, HP Instrument BASIC, beeper, printing, saving instrument states and trace data on a built-in disk, and preset state.

The following list shows the functions controlled by each key in the instrument state block:

System	Controlling HP Instrument BASIC. Adjusting the internal real time clock that is used to print the current time and date on the head of a hard copy. Toggling Beeper ON/OFF. Making Limit Lines and executing Limit Testing. Service Menu (used for testing). See the <i>Service Manual</i> for more information.
Local	Setting HP-IB mode and addresses.
Preset	Presetting State.
Copy	Printing screen image, listing measurement data and operating parameters, calibration kit parameters, list sweep table, and limit test table.
Save	Saving instrument states and saving to built-in disk.
Recall	Recall of instrument state and data from built-in disk drive.

The HP-IB programming command is shown in parenthesis following the key or softkey. Characters following the program code separated by a space are parameters of the command.

For example:

- ON|OFF shows that either ON or OFF can be used as a parameter. COUC ON|OFF means COUC ON or COUC OFF.
- [1-7] shows that numerical 1, 2, 3, 4, 5, 6, and 7 can be used as a parameter. SMKR [1-7] ON means SMKR 1 ON, SMKR 2 ON, SMKR 3 ON, SMKR 4 ON, SMKR 5 ON, SMKR 6 ON, and SMKR 7 ON.

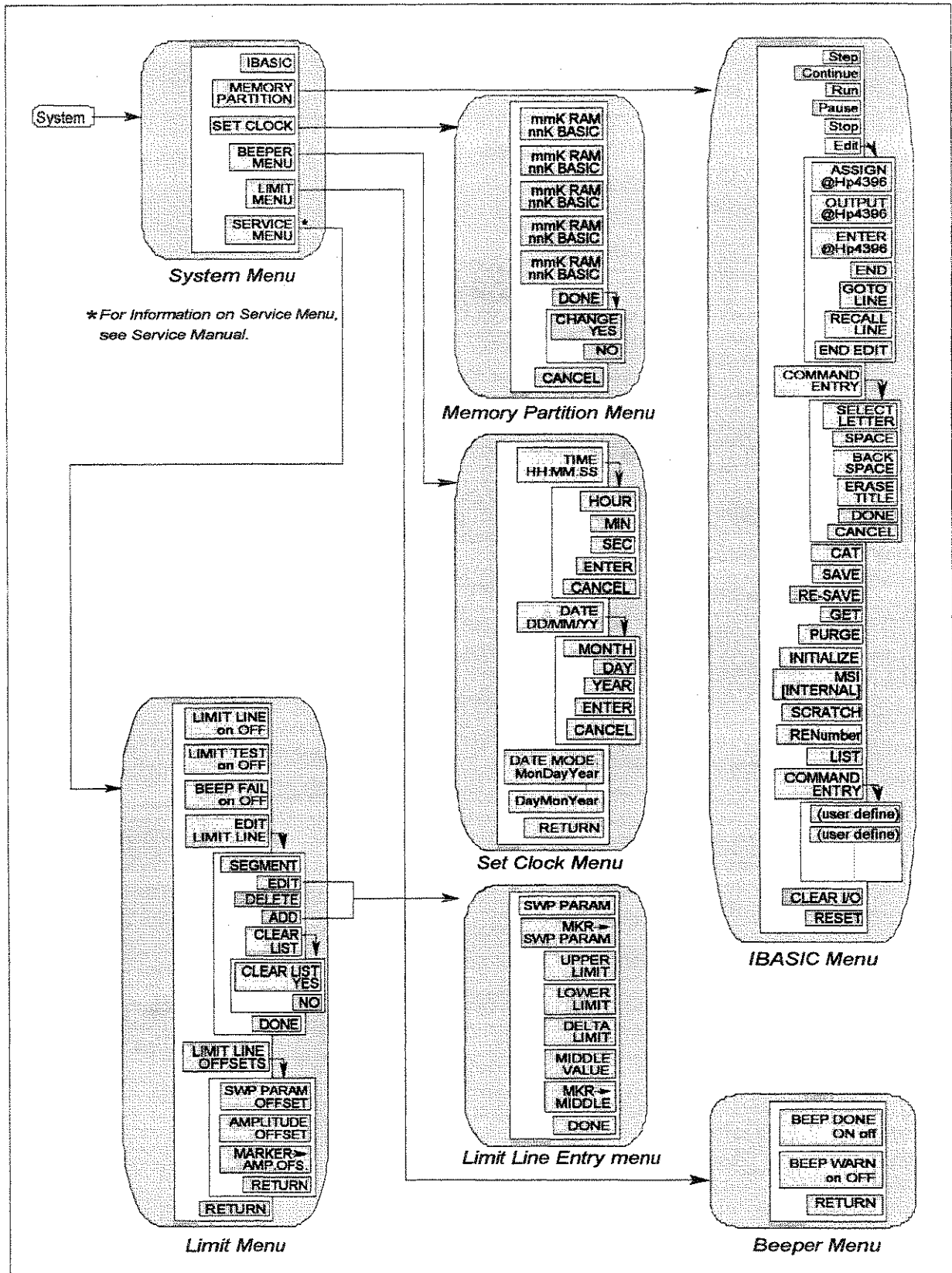

Figure 8-1. Softkey Menus Accessed from the **System** Key

System Menu
Network Analyzer
Spectrum Analyzer

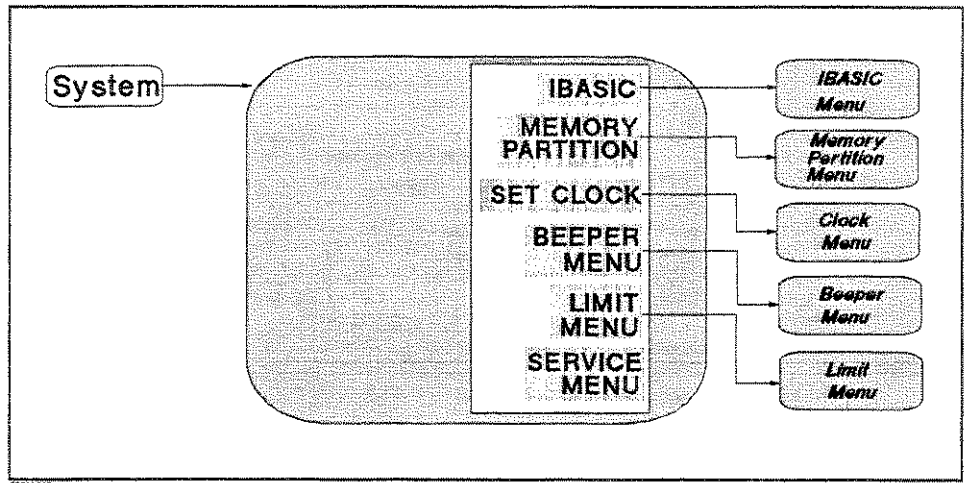
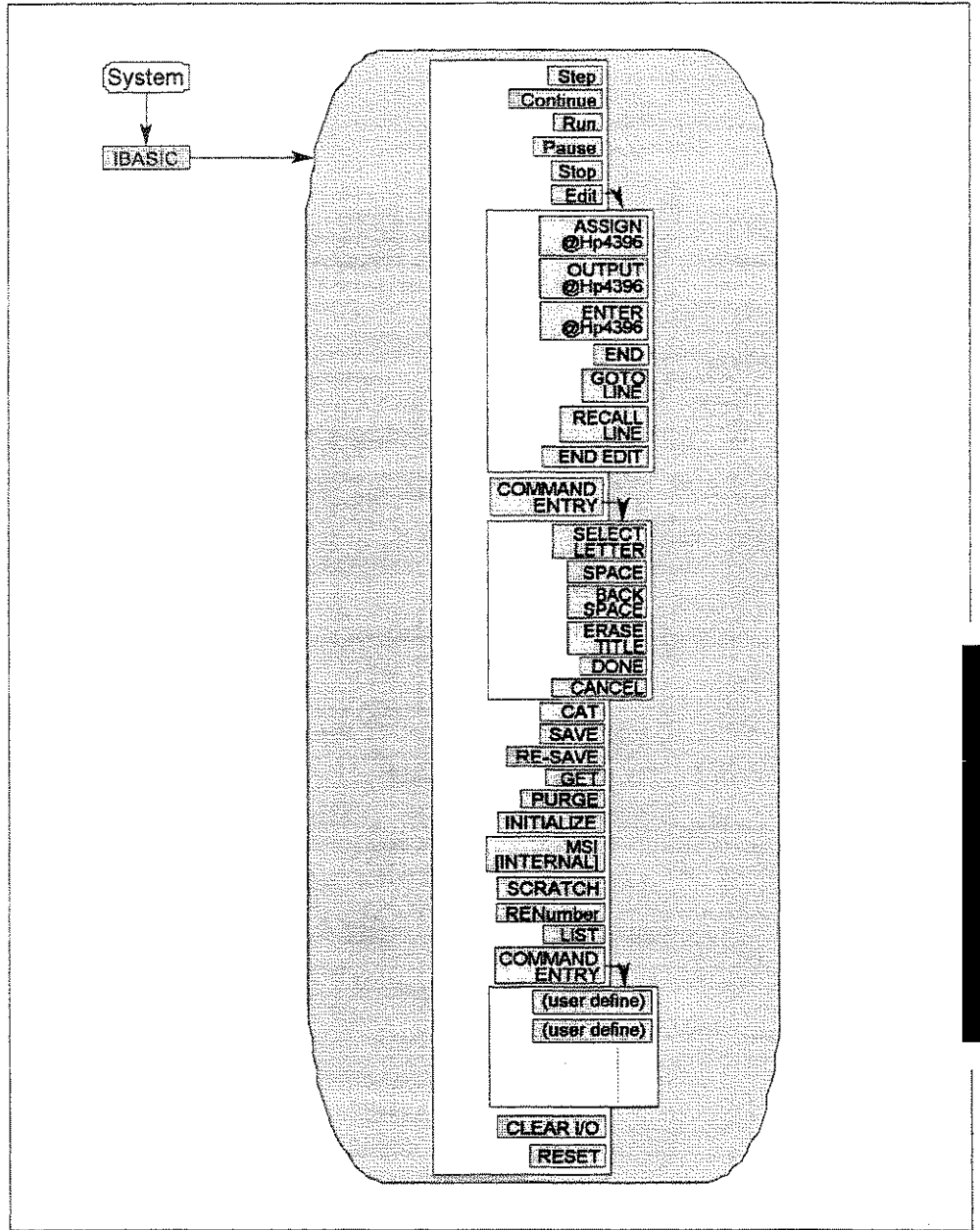

Figure 8-2. System Menu

IBASIC	IBASIC Displays the menu used to operate HP Instrument BASIC.
MEMORY PARTITION	MEMORY PARTITION Changes the size of memory areas for HP Instrument BASIC and the RAM Disk.
CLOCK	SET CLOCK Displays the series of menus that set an internal clock.
BEEPER	BEEPER MENU Displays the series of menus that set a beeper.
LIMIT TESTING	LIMIT MENU Displays the series of menus that defines limits or specifications used to test a DUT.
SERVICE FUNCTION	SERVICE MENU Displays the series of service menus described in detail in the <i>Service Manual</i> .

HP Instrument BASIC Menu

Network Analyzer
Spectrum Analyzer



CB008008

Figure 8-3. IBASIC Menu

CONTROL PROGRAM

Step

Allows you to execute one program line at a time. This is particularly useful for debugging.

Continue

Resumes program execution from the point where it paused.

Run

Starts a program from its beginning.

Pause

Pauses program execution after the current program line is executed.

Stop

Stops program execution after the current line. To restart the program, press **Run**.

EDIT PROGRAM

Edit

Enters into the EDIT mode. In the EDIT mode, the following softkeys are displayed on the softkey menu area.

ASSIGN @Hp4396 Produces the command ASSIGN @Hp4396 TO 800 at the cursor's current position.

OUTPUT @Hp4396 Produces the command OUTPUT @Hp4396;" at the cursor's current position.

ENTER @Hp4396 Produces the command ENTER @Hp4396; at the cursor's current position.

END Produces the command END.

GOTO LINE Allows you to move the cursor to any line number or to a label. After pressing **GOTO LINE**, type a line number or a label and then press **Return**. The cursor moves to the specified line or label.

RECALL LINE Recalls the last deleted line.

END EDIT Exits the edit mode.

CAT

Enters the CAT command in the BASIC command line. The CAT command displays the list of files on a disk.

SAVE

Enters the SAVE command in the BASIC command line. The SAVE command saves a program as an ASCII file.

RE-SAVE

Enters the RE-SAVE command in the BASIC command line. The RE-SAVE command overwrites an old file with a new one using the same file name.

GET

Enters the GET command in the BASIC command line. The GET command loads a specified ASCII file into the editor memory.

PURGE

Enters the PURGE command in the BASIC command line. The PURGE command deletes a specified file.

INITIALIZE

Enters the INITIALIZE command in the BASIC command line. The INITIALIZE command formats a disk.

MSI [INTERNAL]

The MSI [INTERNAL] command specifies a disk device. INTERNAL selects the built-in flexible disk; MEMORY selects the built-in RAM disk.

SCRATCH

Enters the SCRATCH command in the BASIC command line. Pressing the **Return** key after the command deletes a currently edited program from the memory.

RENumber

Enters the RENumber command in the BASIC command line. Pressing the **Return** key after the command renumbers the line numbers of a program.

LIST

Enters the LIST command in the BASIC command line. The LIST command outputs the program list to the screen.

COMMAND ENTRY

COMMAND ENTRY

Displays the softkeys that are used to enter BASIC commands. The active entry area displays the letters, digits, and some special characters. Three sets of letters can be scrolled using the step keys, **↑** and **↓**.

SELECT LETTER

Selects the character pointed to by "↑".

SPACE

Inserts a space.

BACK SPACE

Deletes the last character entered.

ERASE TITLE

Deletes all characters entered.

DONE

Terminates command entry and executes the command you entered.

CANCEL

Cancels command and returns to the previous menu.

CLEAR I/O

Enters the CLEAR I/O command in the BASIC command line. The CLEAR I/O command causes the execution of an I/O-related command to pause. Press Continue to resume the execution.

System

RESET

Enters the RESET command in the BASIC command line. The RESET command terminates program execution without confirmation.

Memory Partition Menu

Network Analyzer
Spectrum Analyzer

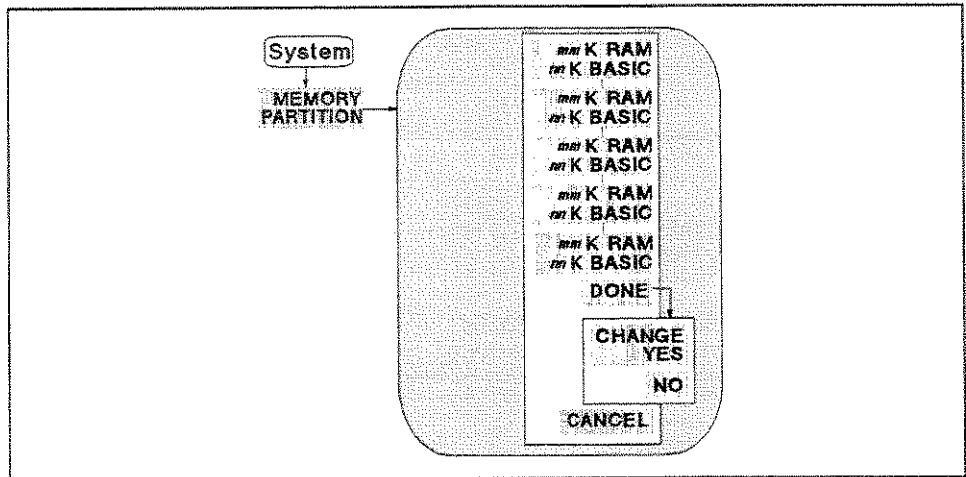

Figure 8-4. Memory Partition Menu

MEMORY PARTITION

nn K RAM mmK BASIC

Selects memory partition so that *mm* Kbyte is used for ram disk and *nn* Kbyte is used for HP Instrument BASIC.

DONE

Displays **CHANGE YES** and **NO** softkey to execute or cancel the change.

CHANGE YES

Change the memory partition to the one selected.

NO

Cancels the change to the memory partition and returns to the previous softkey menu.

Clock Menu

Network Analyzer
Spectrum Analyzer

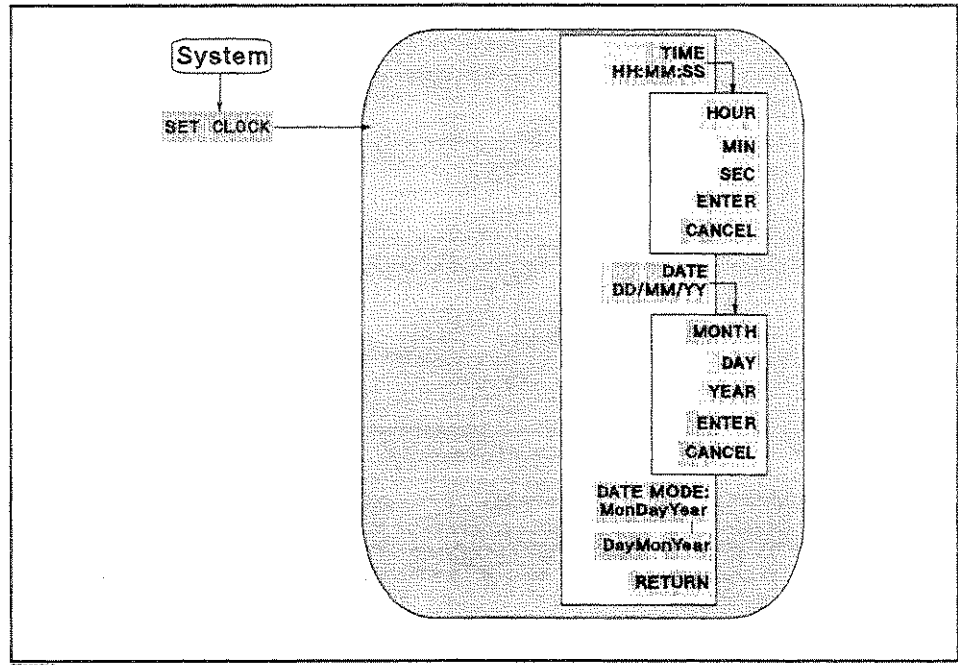

Figure 8-5. Clock Menu

ADJUST TIME

TIME HH:MM:SS (SETCTIME)

Displays the current time on the active entry area and displays the next page to adjust time.

HOUR

enables changing the hour setting using the knob or the numeric entry keys. After you change the hour setting, press **ENTER** to restart the clock.

MIN

enables changing the minute setting using the knob or the numeric entry keys. After you change the minute setting, press **ENTER** to restart the clock.

SEC

enables changing the second setting using the knob or the numeric entry keys. After you change the second setting, press **ENTER** to restart the clock.

ENTER

restarts the internal clock.

CANCEL

returns to the previous page. Pressing this key does not affect the internal clock setting.

ADJUST DATE

DATE MM/DD/YY (SETCDATE)

Displays the current date on the active entry area to adjust date.

MONTH enables changing the month setting using the knob or the numeric entry keys. After you change the month setting, press **ENTER** to restart the clock.

DAY enables changing the day setting using the knob or the numeric entry keys. After you change the day setting, press **ENTER** to restart the clock.

YEAR enables changing the year setting using the knob or the numeric entry keys. After you change the year setting, press **ENTER** to restart the clock.

ENTER restarts the internal clock.

CANCEL returns to the previous page. Pressing this key does not affect the internal clock setting.

DATE FORMAT

DATE MODE: MonDayYear (MONDAYEAR)

Changes the displayed date to the "month:day:year" format.

DayMonYear (DAYMYEAR)

Changes the displayed date to the "day:month:year" format.

System

Beeper Menu
Network Analyzer
Spectrum Analyzer

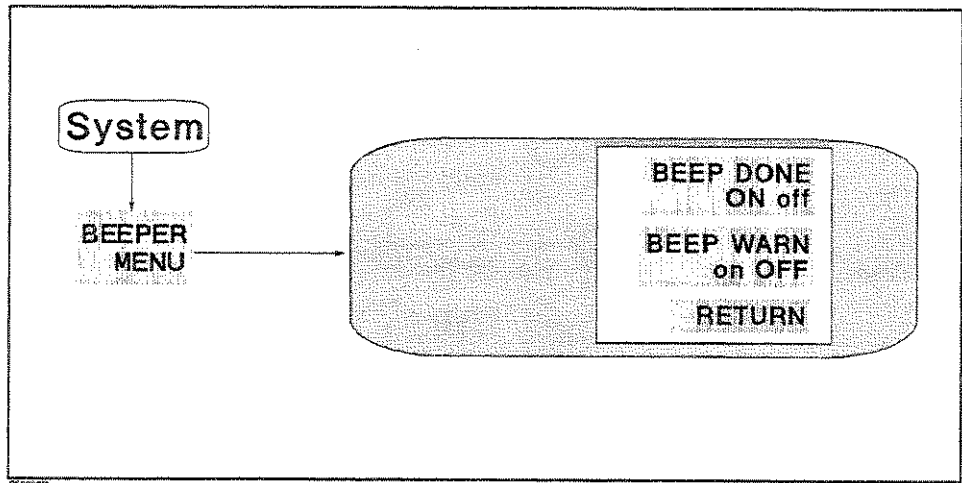

Figure 8-6. Beeper Menu

BEEP DONE

BEEP DONE ON off (BEEPDONE ON|OFF)

Toggles an annunciator that sounds to indicate the completion of operations such as calibration or instrument state save.

BEEP WARNING

BEEP WARN on OFF (BEEPWARN ON|OFF)

Toggles the warning annunciator. When the annunciator is ON it sounds a warning when a cautionary message is displayed.

Limit Line Menu

Network Analyzer
Spectrum Analyzer

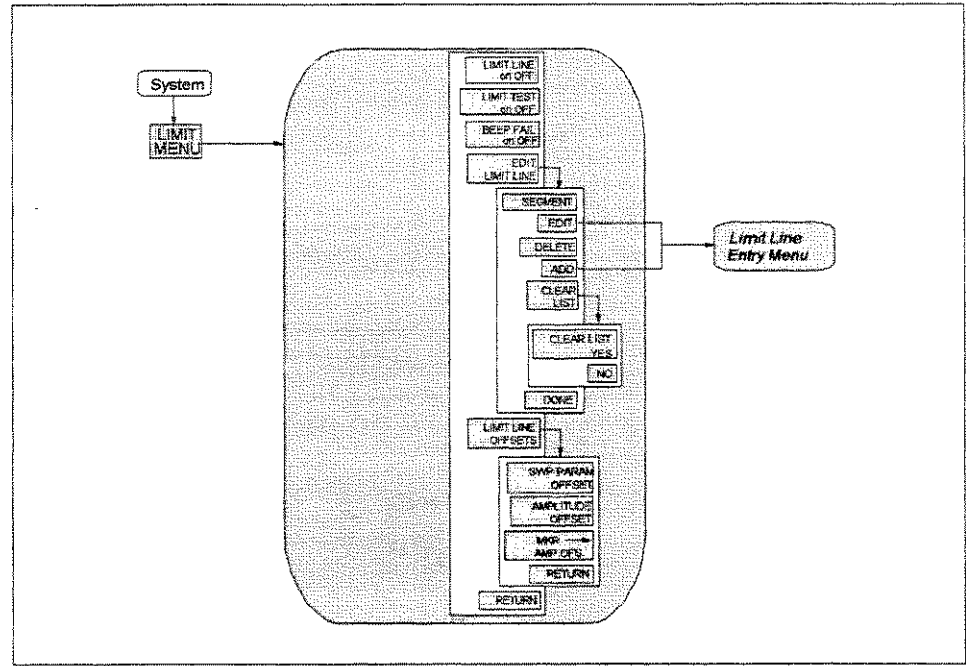

CB908011

Figure 8-7. Limit Line Menu

LIMIT LINE

LIMIT LINE on OFF (LIMILINE ON|OFF)

Turns limit lines ON or OFF. If limits have been defined and limit lines are turned on, the limit lines are displayed for visual comparison of the measured data in all Cartesian formats.

Limit lines can be saved on disk

If limit lines are on, they can be saved on disk with an instrument state.

Limit line table can be listed.

Copy function (accessed from **Copy** key) can list a limit line table. In a listing of values with limit lines on and limit test on, the upper limit and lower limit are listed together with the pass or fail margin, as long as other listed data allows sufficient space.

LIMIT TESTING

LIMIT TEST on OFF (LIMITEST ON|OFF)

Turns limit testing ON or OFF. When limit testing is ON, the data is compared with the defined limits at each measured point. Limit tests occur at the end of each sweep, whenever the data is updated, and when limit testing is first turned ON.

Limit testing is available for both magnitude and phase values in Cartesian formats. In the polar, Smith, and admittance chart formats of the network analyzer, the value tested depends on the marker mode and is the magnitude or the first value in a complex pair. The message "NO LIMIT LINES DISPLAYED" is displayed in polar, Smith, and admittance chart formats if limit lines are turned ON.

Four different ways to indicate pass or fail status
<p>When limit testing is ON, the following five different indications of pass or fail status are provided:</p> <ul style="list-style-type: none"> • A PASS or FAIL message is displayed at the right of the display. • The limit fail beeper sounds if it is turned on. • In a listing of values using the copy menu, an asterisk * is shown next to any measured point that is out of limits. • A bit is set in the HP-IB status byte.

BEEP FAIL

BEEP FAIL on OFF (BEEPFAIL ON|OFF)

Turns the limit fail beeper ON or OFF. When limit testing is ON and the fail beeper is ON, a beep is emitted each time a limit test is performed and a failure detected. The limit fail beeper is independent of the warning beeper and the operation complete beeper, both of which are described in "Beeper Menu."

EDIT LIMIT TABLE

EDIT LIMIT LINE (EDITLIML)

Displays a table of limit segments on the lower half of the display. The edit limits menu is displayed so that limits can be defined or changed.

SEGMENT

Specifies which limit segment in the table to edit. A maximum of eight sets of segment values are displayed at one time and the list can be scrolled up or down to show other segment entries. The pointer ">" shows the segment that can be edited or deleted. The pointer can be moved using the entry block. If the table of limits is designated EMPTY, new segments can be added using **ADD** or **EDIT**.

EDIT (LIMSEDI)

Displays the *limit line entry* menu that defines or modifies the sweep parameter value and limit values of a specified segment. If the table is empty, a default segment is displayed.

DELETE (LIMSDEL)

Deletes the segment indicated by the pointer ">."

ADD (LIMSADD)

Displays the edit segment menu and adds a new segment to the end of the list. The new segment is initially a duplicate of the segment indicated by the pointer ">" and selected using **SEGMENT**. If the table is empty, a default segment is displayed. The maximum number of segments is 18.

CLEAR LIST TABLE

CLEAR LIST (LIMCLEL)

Displays the following softkeys and clears all the segments in the limit test.

CLEAR LIST YES

clears all the segments in the limit line and returns to the previous menu.

NO

cancels clearing the segment and returns to the edit limit menu.

DONE (LIMEDONE)

Sorts the limit segments and displays them on the display in increasing order of sweep parameter values.

LIMIT LINE OFFSET

LIMIT LINE OFFSETS

Displays the following three softkeys that offset the complete limit set in either sweep parameter or amplitude value.

SWP PARAM OFFSET (LIMIPRMO)

Adds to or subtracts an offset from the sweep parameter value. This allows limits already defined to be used for testing in a different sweep parameter range.

AMPLITUDE OFFSET (LIMIAMPO)

Adds or subtracts an offset in amplitude value. This allows previously defined limits to be used at a different power level.

MKR→AMP.OFS. (MKRAMPO)

Move the limits so that they are centered an equal amount above and below the marker at that sweep parameter value.

Note

For information on how to use the limit line and testing function, see Chapter 8 of the *HP 4396B Task Reference*.

Limit Line Entry Menu

Network Analyzer
Spectrum Analyzer

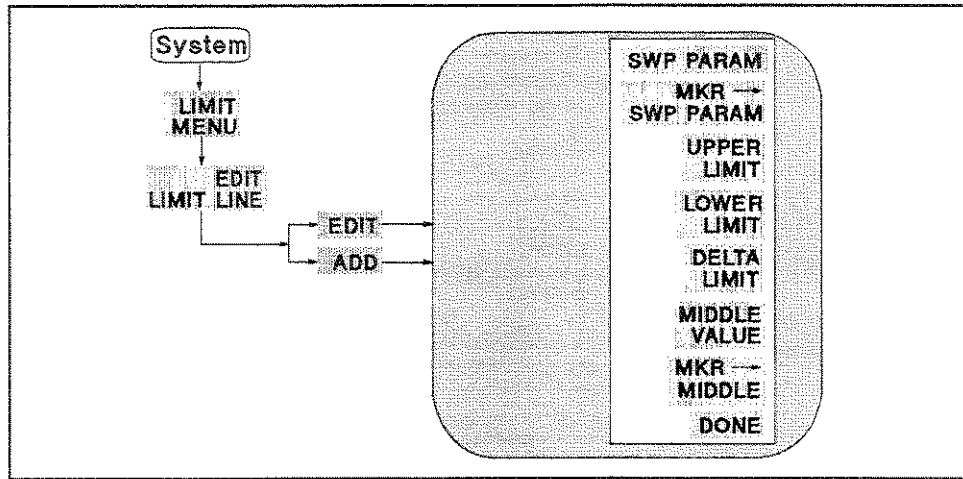

Figure 8-8. Limit Line Entry Menu

SWP PARAM (LIMPRM)

Sets the starting sweep parameter value of a segment using the entry block controls.

MKR → SWP PARAM (MKRSWPRM)

Changes the segment sweep parameter value to the present marker sweep parameter value.

UPPER LIMIT

UPPER LIMIT (LIMU)

Sets the upper limit value for the segment. Upper and lower limits must be defined. If no upper limit is required for a particular measurement, force the upper limit value out of range (for example +500 dB)

When **UPPER LIMIT** or **LOWER LIMIT** is pressed, all the segments in the table are displayed in terms of upper and lower limits, even if they were defined as delta limits and middle value.

If you attempt to set an upper limit that is lower than the lower limit, or vice versa, both limits will be automatically set to the same value.

LOWER LIMIT

LOWER LIMIT (LIML)

Sets the lower limit value for the segment. Upper and lower limits must be defined. If no lower limit is required for a particular measurement, force the lower limit value out of range (for example -500 dB).

DELTA LIMIT

DELTA LIMIT (LIMD)

Sets the limits an equal amount above and below a specified middle value, instead of setting upper and lower limits separately. This is used in conjunction with **MIDDLE VALUE** or **MARKER → MIDDLE**, to set limits for testing a device that is specified at a particular value plus or minus an equal tolerance.

When **DELTA LIMITS** or **MIDDLE VALUE** is pressed, all the segments in the table are displayed in these terms, even if they were defined as upper and lower limits.

MIDDLE VALUE

MIDDLE VALUE (LIMM)

Sets the midpoint for **DELTA LIMITS**. It uses the entry controls to set a specified amplitude value vertically centered between the limits.

MKR → MIDDLE (MKRMIDD)

Sets the midpoint for **DELTA LIMITS** using the marker to set the middle amplitude value of a limit segment. Move the limits so that the limits are automatically set an equal amount above and below the present marker amplitude value.

DONE (LIMSDON)

Terminates a limit segment definition and returns to the last menu.

Local

Local

This key performs the following functions:

- Returns front panel control to the user. The analyzer ignores all front panel keys (except the local key) when under the control of an external computer. The analyzer is in "local mode" when the user has front panel control. The analyzer is in the "remote mode" when an external computer controls the analyzer.
- Gives access to the HP-IB menu that sets the controller mode and to the address menu, where the HP-IB addresses of peripheral devices are entered. The controller mode determines which device controls the HP-IB bus, the analyzer or computer. Only one of them can control the bus at a time.

Local Menu

Network Analyzer
Spectrum Analyzer

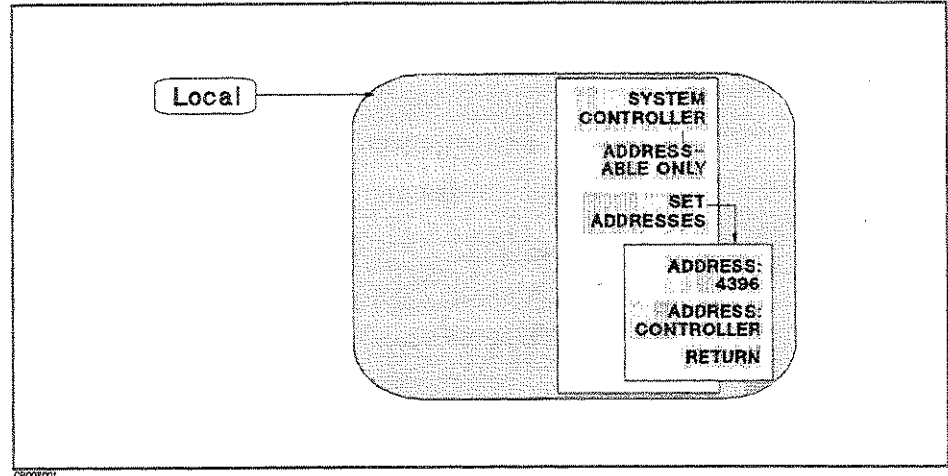

Figure 8-9. Local Menu

SYSTEM CONTROLLER

SYSTEM CONTROLLER

Sets the analyzer as the system controller. This mode is used when peripheral devices are to be used and there is no external controller.

This mode can only be selected manually from the analyzer's front panel and can be used only if no active system controller is connected to the system through HP-IB. If you try to set system controller mode when another system controller is present, the message "CAUTION: CAN'T CHANGE - ANOTHER CONTROLLER ON BUS" is displayed.

ADDRESSABLE

ADDRESSABLE ONLY

Sets the analyzer as addressable only. This mode is used when an external controller controls peripheral devices or the analyzer. This mode is also used when the external computer passes control of the bus to the analyzer.

HP-IB ADDRESS

SET ADDRESSES

Displays the following softkeys:

ADDRESS: 4396

Sets the HP-IB address of the analyzer using the entry controls. There is no physical address switch to set in the analyzer.

ADDRESS: CONTROLLER (ADDRCONT)

Sets the HP-IB address the analyzer will use to communicate with the external controller.

Note



The analyzer keeps the setting of the HP-IB mode and HP-IB addresses in the battery backup memory, even if the analyzer is turned off.

Preset

Preset

Preset key presets the instrument state to the preset default value. The preset default values are listed in Appendix D. **Preset** has no effect on the following states:

- Analyzer Type
- Display Allocation
- Display Adjustment
- Color Adjustment
- Clock Time/Date
- Limit Line Table
- HP-IB Address
- HP-IB Mode (system controller and addressable)
- User Cal Kit Definition

Copy

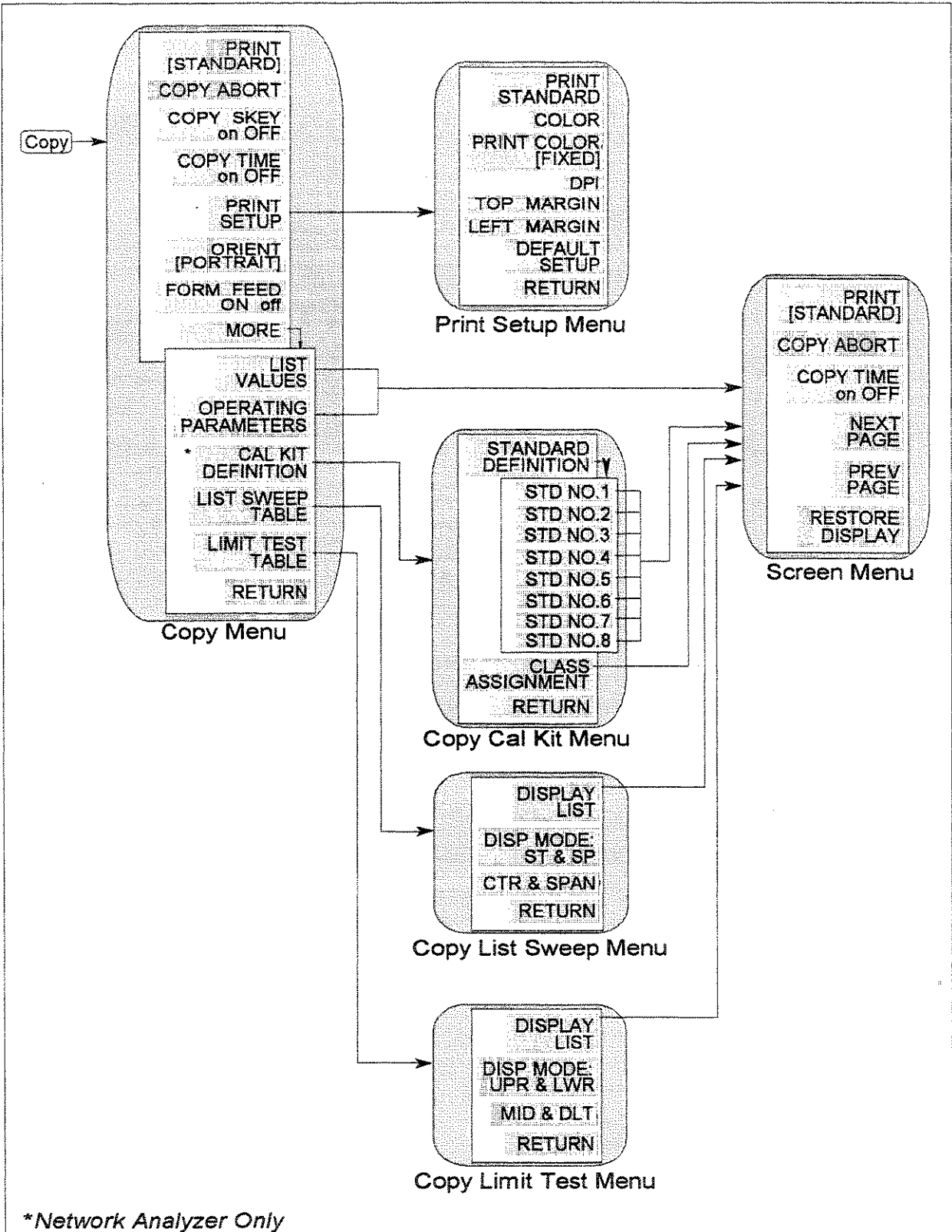

8. Instrument State Block

Figure 8-10. Softkey Menus Accessed from the Copy key Instrument State Block 8-21

Copy Menu

Network Analyzer
Spectrum Analyzer

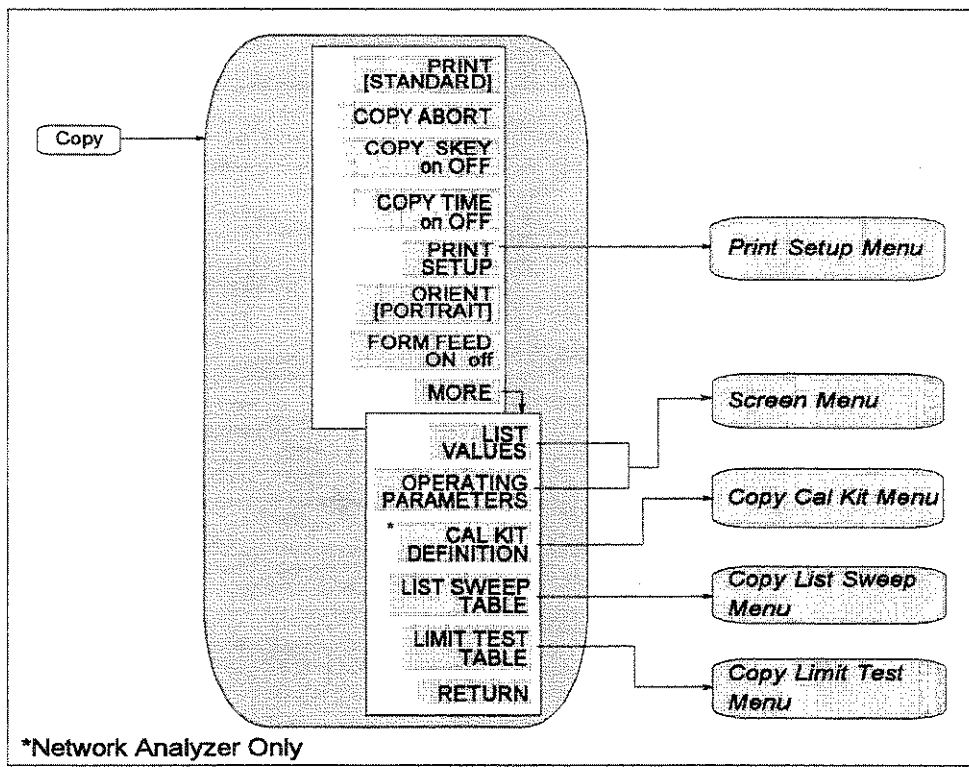

Figure 8-11. Copy Menu

PRINT **PRINT [STANDARD]** (PRINALL)

Causes an exact copy of the display to be printed. The softkey label identifies the printer selected in the print setup menu:

STANDARD For a black and white printer
COLOR For a color printer.

COPY ABORT **COPY ABORT** (COPA)

Aborts a print in progress.

COPY SKEY on OFF (PRSOFT ON|OFF)

Specifies whether to print out softkey labels by switching ON/OFF

TIME STAMP **COPY TIME on OFF** (COPT ON|OFF)

Turns the "time stamp" on or off for a print. When you select print, the time and date are printed out first, followed by the information shown on the display.

PRINT SETUP

Displays the *print setup menu*. This menu allows you to copy the display to a printer capable of graphics or tabular listing. For information on compatible printers, see Chapter 9.

ORIENT [PORTRAIT] (LANDSCAPE ON|OFF)

Specifies the orientation of printer sheets. If your printer does not support landscape printing, this setting is ignored.

PORTRAIT Portrait orientation
LANDSCAPE Landscape orientation

FORM FEED ON off (FORMFEED ON|OFF)

Specifies whether to deliver a sheet after one screen is printed out by switching ON/OFF. When the sheet orientation is specified to LANDSCAPE, the FORMFEED setting is ignored and sheets are always ejected after each screen printout.

LISTING

LIST VALUES (LISV)

Displays the *screen menu*.

This softkey provides a tabular listing of all the measured data points and their current values. When **DUAL CHAN** and **COUPLED CHAN** are **ON**, the measured values of both channels are listed at same time.

When **LIMIT LINE** and **LIMIT TEST** are **ON**, the limit information is also listed together with the measured values. At the same time, the screen menu is displayed to enable hard copy listings and access new pages of the table.

Table 8-1 shows data listed on the screen when **DUAL CHAN** and **COUPLED CHAN** are **OFF**. The margin listed is the smaller of the difference values between the measurement value and either the upper or lower limit. A plus margin means the test passed and a minus margin means it failed.

Table 8-1. List Value Format

Display Format	Values Listed				
	1st column	2nd column	3rd column	4th column	5th column
LOG MAG PHASE DELAY LIN MAG SWR REAL IMAGINARY EXPANDED PHASE	Sweep Parameter	Measurement Data ¹	Margin ²	Upper Limit Value ²	Lower Limit Value ²
SMITH CHART POLAR ADMITTANCE CHART	Sweep Parameter	Measurement Data ¹	Measurement Data	Upper Limit Value ²	Lower Limit Value ²
SPECTRUM NOISE	Sweep Parameter	Measurement Data ¹	Margin ²	Upper Limit Value ²	Lower Limit Value ²

1 An * is displayed at the left of the measurement value when it fails the limit testing.

2 This is listed when the limit test is on.

Network analyzer can list the values measured on both channels

When the dual channel is turned on and both channels are coupled, the sweep parameter value is listed in the first column, the measurement data of the active channel is listed in the second and third columns, and the non-active channel data is listed in the fourth and fifth columns. The values listed for each channel are the same as the data listed in the second and third columns in Table 8-1. The channel coupling capability is available only when both channels are in the network analyzer mode.

List values converted to impedance or admittance

LIST VALUES lists log magnitude values when the log magnitude format is selected as the display format, even if impedance (Z:trans, Z:refl) or admittance (Y:trans, Y:refl) is displayed using the Conversion function (and the markers show the absolute values).

PARAMETER LIST

OPERATING PARAMETERS (OPEP)

Displays the *screen menu*. Provides a tabular listing on the display of the key parameters for both channels. The screen menu is presented to allow hard copy listings and access new pages of the table.

Parameters listed by OPERATION PARAMETERS

The following operating parameters are listed in four pages:

- Number of points
- Sweep time
- Source power
- Port-1 and 2 attenuator
- Bandwidth
- Averaging factor
- Averaging switch
- Group delay aperture
- Calibration kit
- Z_0
- Calibration type
- Sweep conditions when the calibration was performed
- Phase offset
- Port 1 and 2 extension
- Input R, A, and B extension
- Velocity factor

CAL KIT LIST

CAL KIT DEFINITION

Displays the *copy cal kit menu* that prints the calibration kit definitions.

SWEEP TABLE

LIST SWEEP TABLE

Displays the *copy list sweep menu* that can display a tabular listing of the list sweep table and print it.

LIMIT TABLE

LIMIT TEST TABLE

Displays the *copy limit test menu* that can display a tabular listing of the limit value for limit testing and print it.

Print Setup Menu

Network Analyzer
Spectrum Analyzer

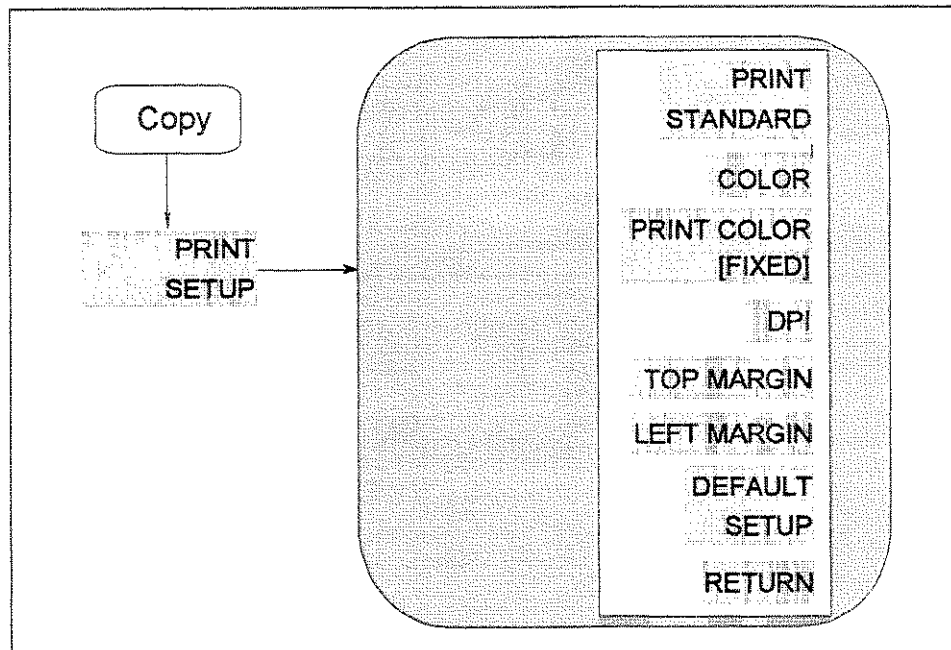

CB008014

Figure 8-12. Print Setup Menu

PRINT STANDARD (PRIS)

The analyzer prints a hard copy with monochrome.

COLOR PRINT

COLOR (PRIC)

Sets the print command to a default of color. The **PRINT [COLOR]** command does NOT work with a black and white printer.

PRINT COLOR [FIXED] (PRICFIXE, PRICVARI)

Toggles the printing color between **[FIXED]** and **[VARIABLE]**. If **FIXED** is selected, the analyzer prints a hard copy with default colors. If **VARIABLE** is selected, the analyzer prints a hard copy with colors as similar as possible to the display colors (that can be adjusted). See **Display** in Chapter 5 for display colors adjustment.

Note



Because of the limited number of printer ink colors, the printed color is not always the same as the displayed color.

DPI (DPI)

Specifies the resolution of a printer used for printing by dpi. The range of settable resolution is between 75 and 600 dpi.

TOP MARGIN (TMARG)

Specifies the top margin of printing by inch. The settable margin range is between 0 and 5 inches in step of 0.1 inch.

Copy

LEFT MARGIN (LMARG)

Specifies the left margin of printing by inch. The settable margin range is between 0 and 5 inches in step of 0.1 inch.

DEFAULT SETUP (DFLT)

Resets the printing parameters to the following default settings.

• Printing resolution:	75 dpi
• Form feed:	ON
• Sheet orientation:	Portrait
• Softkey label printing:	OFF
• Top margin:	1.0 inch
• Left margin:	1.0 inch

Copy Cal Kit Menu

Network Analyzer
Spectrum Analyzer

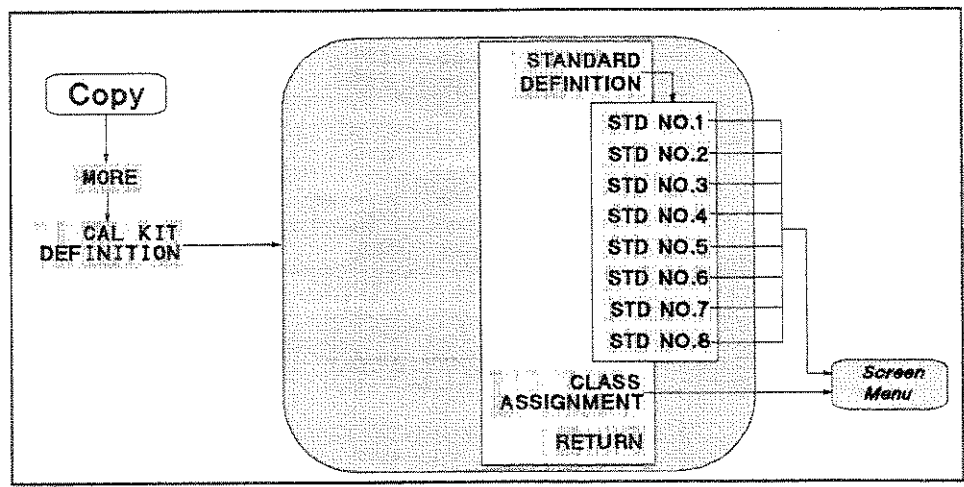

Figure 8-13. Copy Cal Kit Menu

STANDARD LIST

STANDARD DEFINITION (CAL S [1-7])

Displays the menu that selects which standard settings are to be hard copied.

- STD NO.1
- STD NO.2
- STD NO.3
- STD NO.4
- STD NO.5
- STD NO.6
- STD NO.7
- STD NO.8

These softkeys provide the tabular listing of the standard definitions of the standard number 1 to 8 and provide the screen menu to prepare for hard copy.

CLASS LIST

CLASS ASSIGNMENT (CALCASSI)

Shows the tabular listing of the cal kit class assignment and provides the screen menu to prepare for hard copy.

Copy

Copy Limit Test Menu

Network Analyzer
Spectrum Analyzer

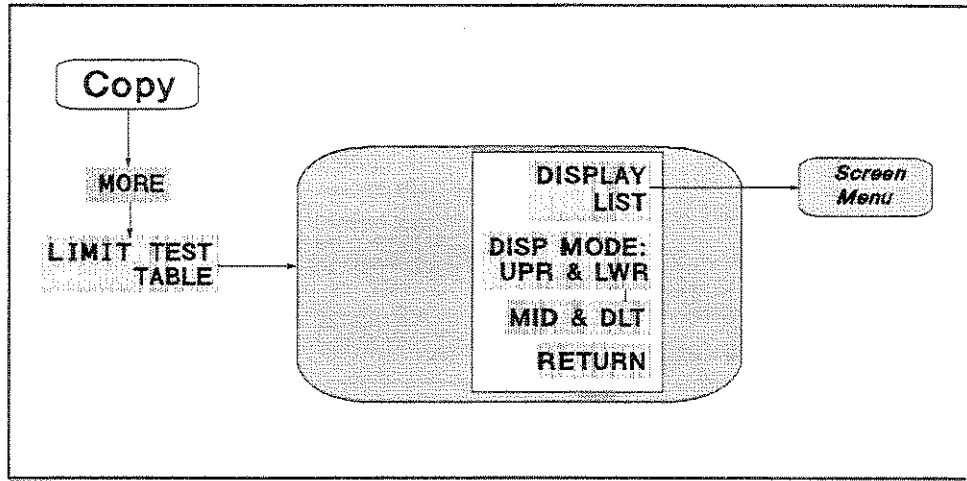

Figure 8-14. Copy Limit Test Menu

DISPLAY LIST (DISLLIST)

Displays the limit testing table and the screen menu to prepare for hard copy.

DISP MODE: UPR & LWR (DISMAMP UL)

Selects the upper and lower formats that display the upper limit and lower limit values.

MID & DLT (DISMAMP MD)

Selects the middle and delta formats that display the middle value and the maximum deviation (limit value) from the middle value.

Copy List Sweep Menu

Network Analyzer
Spectrum Analyzer

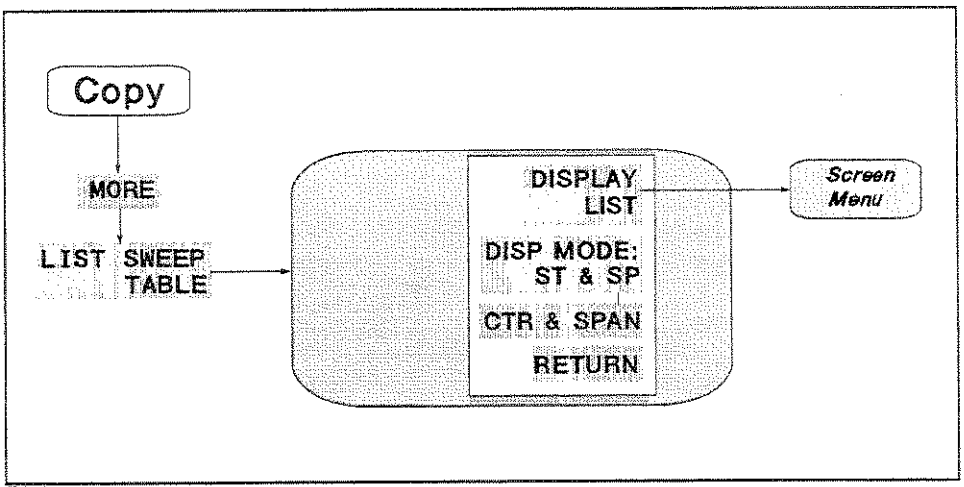

Figure 8-15. Copy List Sweep Menu

LIST TABLE

DISPLAY LIST (DISL)

Displays the limit testing table and leads to the screen menu to prepare for hard copy.

DISP MODE: ST & SP (DISMPRM STSP)

Selects the start/stop format to list the sweep parameter.

CTR & SPAN (DISMPRM CTSP)

Selects the center/span format to list the sweep parameter.

Copy

Screen Menu

Network Analyzer
Spectrum Analyzer

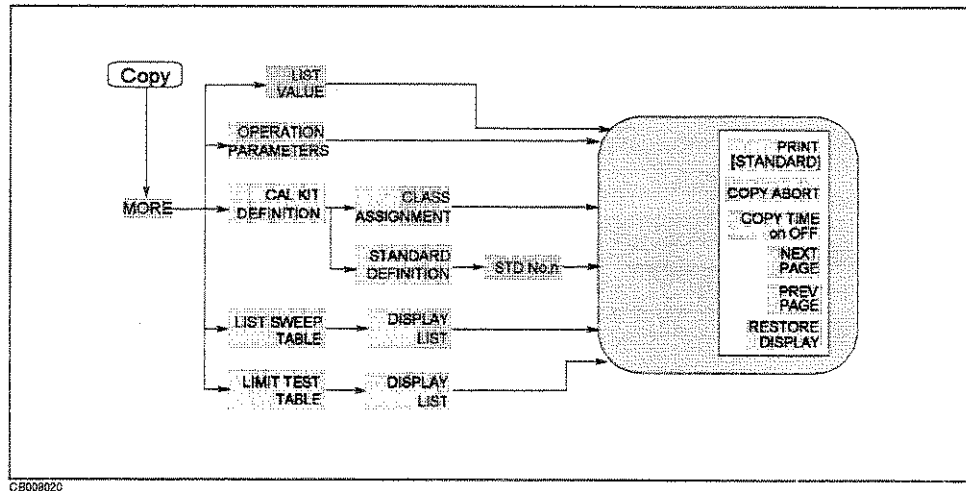

CB008020

Figure 8-16. Screen Menu

PRINT **PRINT [STANDARD]** (PRINALL)

Copies one page of the tabular listings to a printer. Either **STANDARD**, for a black and white printer, or **COLOR**, for a color printer, is shown in brackets(" []"). This identifies which printer is selected as the default in the print setup menu. The default setting at power on is standard. Default text for a color printer is black.

COPY ABORT **COPY ABORT** (COPA)

Aborts a print in progress.

TIME STAMP **COPY TIME on OFF** (COPT ON|OFF)

Turns printing time and date ON or OFF. When you select print, the time and date are printed first then the information displayed.

NEXT PAGE (NEXP)

Displays the next page of information in a tabular listing .

PREV PAGE (PREP)

Displays the previous page of information in a tabular listing.

RESTORE DISPLAY (RESD)

Turns off the tabular listing and returns the measurement display to the screen.

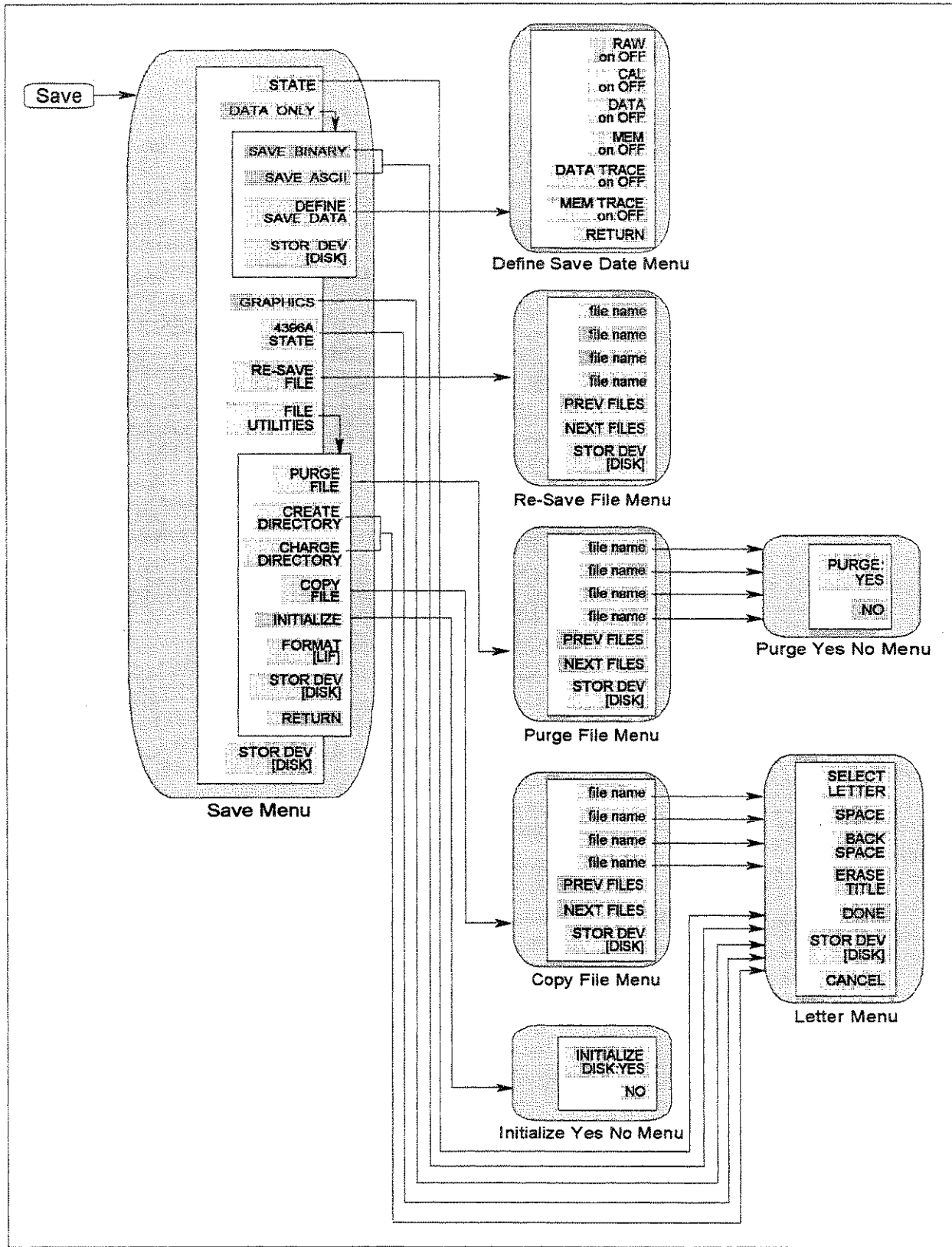

CB098036

Figure 8-17. Softkey Menus Accessed from the **Save** Key, Instrument State Block 8-31

Save

Save Menu

Network Analyzer
Spectrum Analyzer

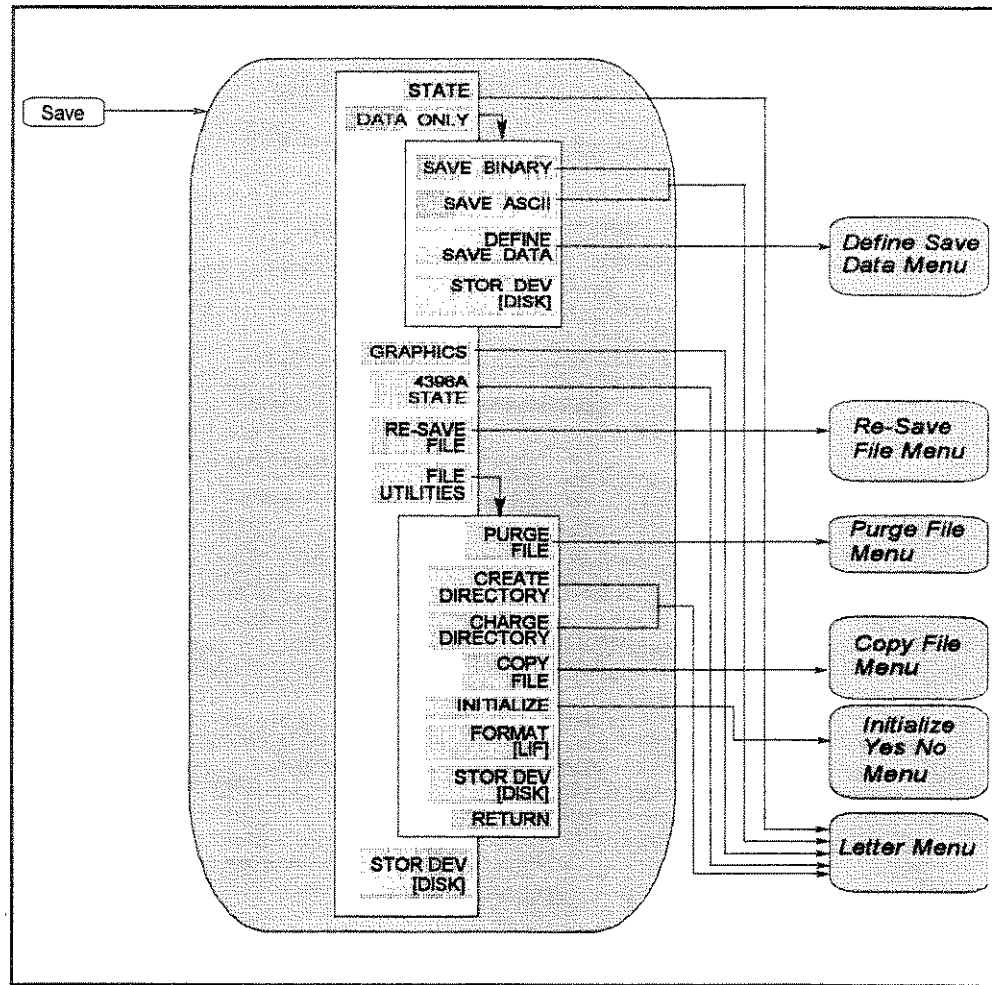

CB008021

Figure 8-18. Save Menu

SAVE STATE **STATE** (SAVDSTA)

Specifies saving the instrument states, the calibration coefficients and measurement data.

SAVE DATA **DATA ONLY**

Displays the menu used to save data.

Note



DATA ONLY does not save instrument settings such as start and stop frequencies. BE CAREFUL! Always make sure that you save the existing STATE if you want to use the setup again.

SAVE BINARY (SAVDDAT)

DEFINE SAVE DATA

Displays the *define save data menu* that selects the applicable data arrays to be saved.

ASCII SAVE

SAVE ASCII (SAVDASC)

Specifies saving the internal data arrays as an ASCII file. The arrays saved are defined by the **DEFINE SAVE DATA** key.

DEFINE SAVE DATA

Displays the *define save data menu* that selects the applicable data arrays to be saved.

STOR DEV[] (STODDISK, STODMEMO)

Selects between the flexible disk drive and the RAM disk memory as the storage device. **[DISK]** shows the built-in flexible disk is selected and **[MEMORY]** shows the RAM disk memory is selected.

GRAPHICS (SAVDTIFF)

Specifies the file format for saving the screen currently displayed as the TIFF format. The colors to be used in a saved image are controlled by your setting in the *Print Setup Menu*, which provides the options; **PRINT:STANDARD**, **PRNT COLOR [FIXED]** or **PRNT COLOR [VARIABLE]**. Softkeys are also saved.

4396A STATE (SAVDSTAC)

Saves the instrument state and the internal data arrays in the format so that the 4396A can recall.

Note

Following settings are not saved.

- Printing resolution (dpi)
- Sheet orientation
- Form feed
- Top margin
- Left margin
- Softkey label printing

OVER WRITE

RE-SAVE FILE (RESAVD)

Displays the Re-save File menu used to update a file that is already saved.

FILE UTILITIES

Displays softkeys that initializes a new disk and purges a file from a disk.

DIRECTORY

CREATE DIRECTORY (CRED)

Specifies creating a new directory in a DOS format disk. This function is not available for LIF files.

CHANGE DIRECTORY (CHAD)

Specifies changing the current directory of a DOS format disk. This function is not available for LIF files.

COPY FILE

COPY FILE (FILC)

Copies files. When a file is copied between the flexible disk and the RAM disk memory, the disk formats of the disk and the RAM disk memory must be same format.

INITIALIZE

INITIALIZE (INID)

Displays the Initialize menu. A new disk must be initialized before data is stored on it. The disk can be formatted in either LIF or DOS format.

DISK FORMAT

FORMAT [] (DISF LIF|DOS)

Toggles the disk format between the LIF and DOS formats that are used when initializing a new disk. This setting does not change even when the line power is cycled or the **Preset** key is pressed. The factory setting is LIF.

STORAGE DEVICE

STOR DEV[] (STODDISK, STODMEMO)

Selects between the flexible disk drive and the RAM disk memory as the storage device. **[DISK]** shows the built-in flexible disk is selected and **[MEMORY]** shows the RAM disk memory is selected.

Note



Use the built-in flexible disk to store important data because the RAM disk data is lost when the power is turned off.

The storage selection does not change even when the line power is cycled or the **Preset** key is pressed.

For more information on the save function, see Appendix C.

Define Save Data Menu

Network Analyzer
Spectrum Analyzer

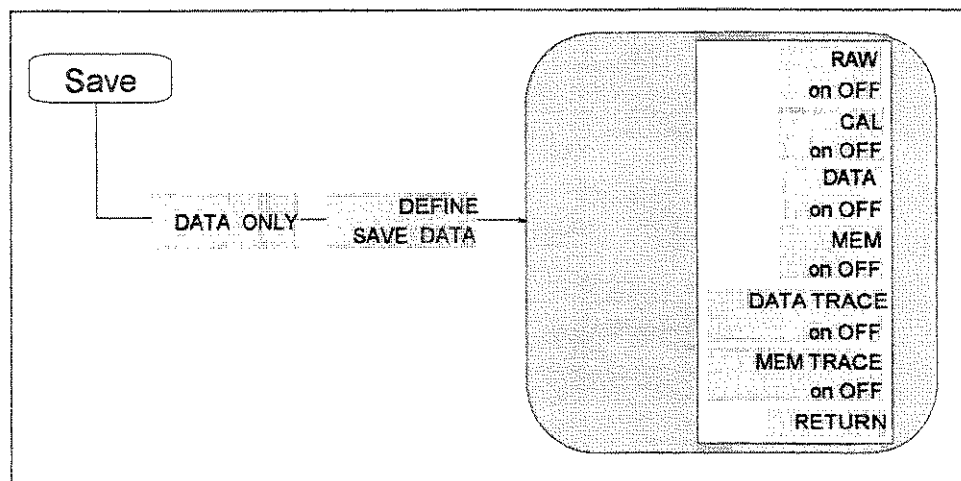

CB008027

Figure 8-19. Define Save Data Menu

RAW on OFF (SAVRAW ON|OFF)

Toggles saving or not saving the raw data arrays.

CAL on OFF (SAVCAL ON|OFF)

Toggles saving or not saving the calibration coefficients arrays. The calibration coefficients arrays are available for only the network analyzer. No data is saved when the spectrum analyzer is selected.

DATA on OFF (SAVDAT ON|OFF)

Toggles saving or not saving the data arrays.

MEM on OFF (SAVMEM ON|OFF)

Toggles saving or not saving the memory arrays.

DATA TRACE on OFF (SAVDTRC ON|OFF)

Toggles saving or not saving the trace arrays.

MEM TRACE on OFF (SAVMTRC ON|OFF)

Toggles saving or not saving the memory trace arrays.

Note



For more information on the save function, see Appendix C.

Save

Re-Save File Menu

Network Analyzer
Spectrum Analyzer

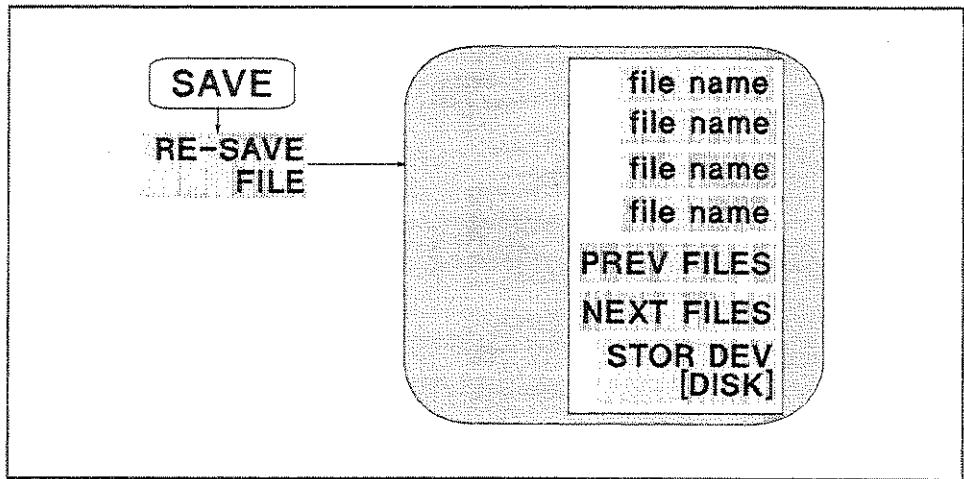

Figure 8-20. Re-save file menu

file name (RESAVED)

Updates the file previously saved with the current instrument states or data. The data group to be saved is determined by the file name's extension. See "File Names" in Appendix C for more details about file name extensions.

PREV FILES

Displays the previous file names in the softkey label to re-save data.

NEXT FILES

Displays the next file names in the softkey label to re-save data.

STOR DEV[] (STODDISK, STODMEMO)

Selects between the flexible disk drive and the RAM disk memory as the storage device. **[DISK]** shows the built-in flexible disk is selected and **[MEMORY]** shows the RAM disk memory is selected. This setting does not change even when the line power is cycled or the **Preset** key is pressed.

Purge File Menu

Network Analyzer
Spectrum Analyzer

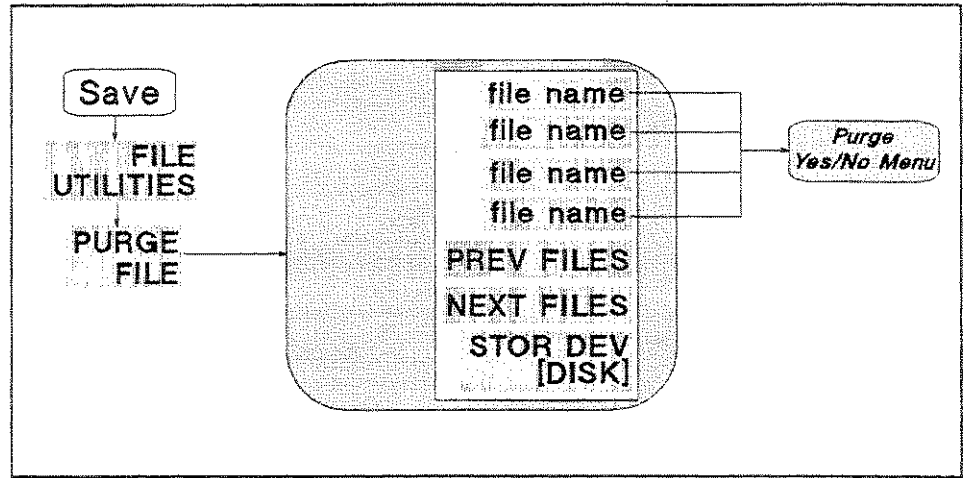

Figure 8-21. Purge File Menu

file name (PURG)

Selects a file to be purge from the disk or the RAM disk.

PREV FILES

Displays the previous file names in the softkey label to purge file.

NEXT FILES

Displays the next file names in the softkey label to purge file.

STOR DEV[] (STODDISK, STODMEMO)

Selects between the flexible disk drive and the RAM disk memory as the storage device. **[DISK]** shows the built-in flexible disk is selected and **[MEMORY]** shows the RAM disk memory is selected. This setting does not change even when the line power is cycled or the **Presets** key is pressed.

Save

Purge Yes No Menu

Network Analyzer
Spectrum Analyzer

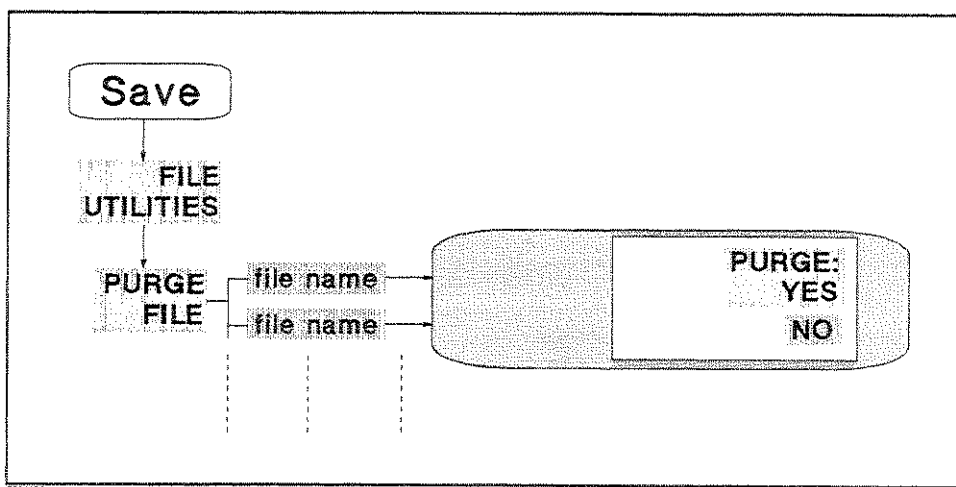

Figure 8-22. Purge Yes No Menu

PURGE: YES

Removes the file and returns to the previous menu.

NO

Returns to the previous menu without purging the file.

Initialize Yes No Menu

Network Analyzer
Spectrum Analyzer

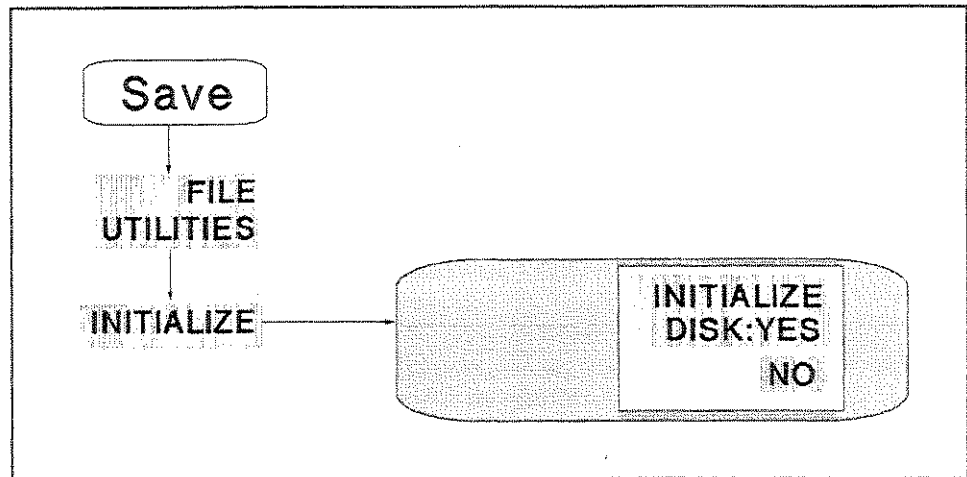

Figure 8-23. Initialize Yes No Menu

INITIALIZE DISK: YES

Initializes the disk or the RAM disk. When the flexible disk is selected for initialization, **DISK** is displayed in the softkey label, When the RAM disk memory is selected, **MEMORY** is displayed.

NO

Returns to the previous menu without initialize the flexible disk or the RAM disk memory.

Save

Letter Menu

Network Analyzer
Spectrum Analyzer

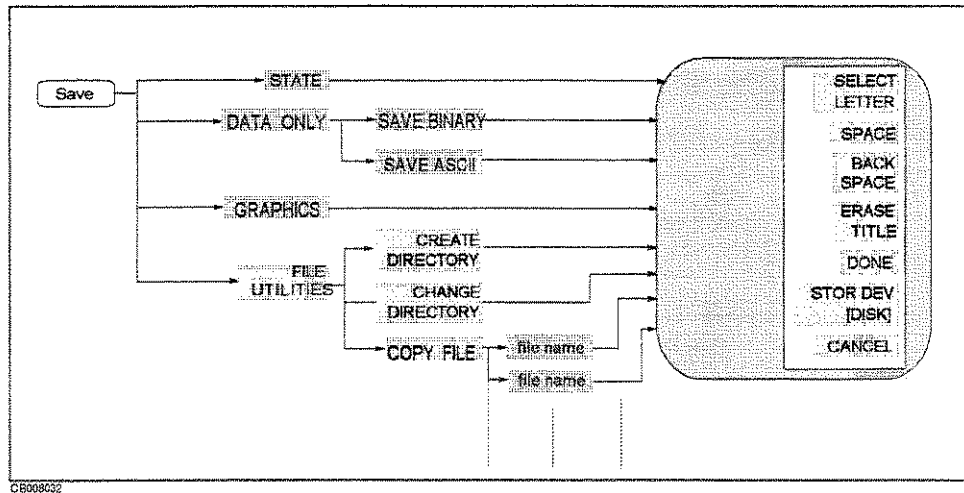

Figure 8-24. Letter Menu for **Save** Key

ENTER CHARACTERS

SELECT LETTER

Selects the letter pointed to by the arrow “↑” on the screen. The arrow can be moved by rotating the knob.

SPACE

Inserts a space in the title.

BACK SPACE

Deletes the last character entered.

ERASE TITLE

Deletes the entire title.

DONE

Terminates the title entry and returns to the display more menu.

STOR DEV [] (STODDISK, STODMEMO)

Selects between the flexible disk drive and the RAM disk memory as the storage device. **[DISK]** shows the built-in flexible disk is selected and **[MEMORY]** shows the RAM disk memory is selected. This setting does not change even when the line power is cycled or the **Preset** key is pressed.

CANCEL

Cancels the title entry and returns to the display more menu without any change.

Recall

Recall Menu

Network Analyzer
Spectrum Analyzer

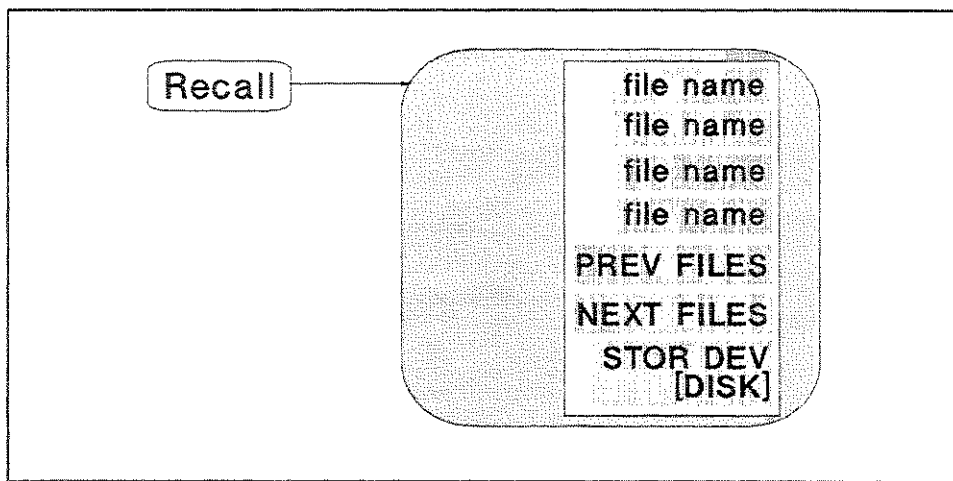

Figure 8-25. Recall Menu

file name (RECD)

Selects a file to be loaded and loads the instrument state or data.

PREV FILES

Displays the previous set of file names on the softkey label to load data.

NEXT FILES

Displays the next set of file names on the softkey label to load data.

STOR DEV [] (STODDISK, STODMEMO)

Selects between the flexible disk drive and the RAM disk memory as the storage device. **[DISK]** shows the built-in flexible disk is selected and **[MEMORY]** shows the RAM disk memory is selected. This setting does not change even when the line power is cycled or the **[Preset]** key is pressed.

AUTO RECALL

Auto Recall Function
When the analyzer is turned on, it looks for a file named "AUTOREC" from the built-in flexible disk, and if found, the analyzer automatically reads the file to retrieve its data.

Accessories and Options

Options Available

High Stability Frequency Reference (Option 1D5)

This option, a 10 MHz crystal in temperature stabilized oven, improves the source signal frequency accuracy and stability. This option can be retrofitted using the HP 4396U Upgrade Kit Option 1D5.

Time-Gated Spectrum Analyzer (Option 1D6)

This option allows the capability of intermittent or burst signal spectrum measurement. This option can be retrofitted using the HP 4396U Upgrade Kit Option 1D6.

50 to 75 Ω Input Impedance Conversion (Option 1D7)

This option offers 75 Ω input impedance for the spectrum measurement. The HP 11852B option C04 50 to 75 Ω minimum loss pads and 50 Ω to 75 Ω BNC adapters are furnished and the supplemental characteristics are supplied with this option. This option can be retrofitted using the HP 4396U Upgrade Kit Option 1D7.

Impedance Measurement Function (Option 010)

This option allows the capability of impedance measurement function. This option can be retrofitted using the HP 43961A Impedance Test Kit.

Keyboard less (Option 1AC)

This option not furnished the mini-DIN keyboard for HP Instrument BASIC.

Handle Kit (Option 1CN)

This option is a rack mount kit containing a pair of handles and the necessary hardware to mount the instrument.

Rack Mount Kit (1CM) This option is a rack mount kit containing a pair of flanges and the necessary hardware to mount the instrument, with handles detached, in an equipment rack with 482.6 mm (19 inches) horizontal spacing.

Rack Mount and Handle Kit (Option 1CP)

This option is a rack mount kit containing a pair of flanges, and the necessary hardware to mount the instrument with handles attached in an equipment rack with 482.6 mm (19 inches) horizontal spacing.

Measurement accessories available

Test Sets

HP 85046A/B S Parameter Test Set

These test sets contain the hardware required to measure all four S-parameters of a two-port 50 or 75 Ω device. An RF switch in the test set is controlled by the analyzer so that reverse measurement can be made without changing the connections to the DUT (device under test). Each test set also contains two internal dc bias tees for biasing active devices. The test port connectors for the HP 85046A are precision 7 mm connectors, and the HP 85046B test port connectors are 75 Ω type-N(f).

HP 87512A/B Transmission/Reflection Test Set

These test sets contain the hardware required to measure simultaneous transmission and reflection characteristics of a 50 or 75 Ω device in one direction only. The test port connector is 50 Ω type-N(f) on the HP 87512A and 75 Ω type-N(f) on the HP 87512B.

Active Probes

HP 85024A High Frequency Probe (300 kHz to 3 GHz)

This is a high input impedance probe for in-circuit measurements that cover the frequency range of 300 kHz to 3 GHz.

HP 41800A Active Probe (5 Hz to 500 MHz)

This is a high input impedance probe for in-circuit measurements that cover the frequency range of 5 Hz to 500 MHz.

HP 41802A 1 M Ω Input Adapter (5 Hz to 100 MHz)

This adapter allows use of a high impedance probe. It has a frequency range of 5 Hz to 100 MHz.

HP 54701A Active Probe (DC to 2.5 GHz)

This is a high input impedance probe for in-circuit measurements that cover the frequency range up to 2.5 GHz with 100 k Ω input impedance. The HP 54701A must be used with the HP 1143A Probe Offset Control and Power Module.

HP 11945A Close-field Probe Set

This includes both the HP 11940A and HP 11941A probes for full coverage from 9 kHz to 1 GHz. Option E51 adds the HP 8447F Option H64 dual preamplifier, a 36 in (914 mm) Type N cable, and a carrying bag for storage and protection of the entire set.

HP 1141A Differential Probe

This is an FET differential probe with 200 MHz bandwidth and 3000:1 CMRR. The HP 1141A must be used with the HP 1142A Probe Control and Power Module.

Preamplifier

HP 10855A Broadband Preamplifier (2 MHz to 1300 MHz)

This preamplifier provides a minimum of 22 dB gain from 2 MHz to 1300 MHz to enhance measurements of very low-level signals. The ± 1.5 dB flat response reduces distortion in non-sinusoidal wave forms. The HP 10855A operates with the probe power outlets or with the HP 1122A Probe Power Supply.

HP 87405A Preamplifier (10 MHz to 3000 MHz)

This preamplifier provides a minimum of 24 dB gain from 10 MHz to 3000 MHz to enhance measurements of very low-level signals. The HP 87405A operates with the probe power outlets or with the HP 11899A Probe Power Supply.

Power Splitters and Directional Bridges

HP 11850C,D Three-way Power Splitters

These are four-port, three-way power splitters. One output arm is used as the reference for the network analyzer in making ratio measurements and the other two output arms are test channels. The HP 11850C has a frequency range of DC to 3 GHz and an impedance of 50 Ω . The HP 11850D has a frequency range of DC to 2 GHz and an impedance of 75 Ω . Three HP 11852B 50 to 75 Ω minimum loss pads are supplied with the HP 11850D power splitter to provide a low SWR impedance match between the power splitter and the 50 Ω ports of the network analyzer.

HP 11667A Power Splitter

This is a two-way power splitter with one output arm used for reference and one for test. It has a frequency range of DC to 18 GHz and an impedance of 50 Ω .

HP 86205A/HP 86207A 50 Ω and 75 Ω RF Bridges

These are high directivity RF Bridges used for general purpose applications. The HP 86205A has a frequency range of 300 kHz to 6 GHz and an impedance of 50 Ω . The HP 86207A has a frequency range of 300 kHz to 3 GHz and an impedance of 75 Ω .

Calibration Kits

The following calibration kits contain the precision standards (and the required adapters) for the indicated connector types. The standards facilitate measurement calibration (also called vector error correction). Refer to the applicable data sheet and ordering guide for additional information. Part numbers for the standards are in their respective manuals.

- HP 85033C 3.5 mm Calibration Kit
- HP 85031B 7 mm Calibration Kit
- HP 85032B 50 Ω Type-N Calibration Kit
- HP 85036B 75 Ω Type-N Calibration Kit

Cables

The following RF cables are used to return the transmitted signal to the test set when measuring two-port devices. These cables provide shielding for high dynamic range measurements.

HP 11857D 7 mm Test Port Return Cable Set

These are a pair of test port return cables for use with the HP 85046A S-parameter test set. The cables can be used when measuring devices with connectors other than 7 mm by using the appropriate precision adapters.

HP 11857B 75 Ω Type-N Test Port Return Cable Set

These are a pair of test port return cables for use with the HP 85046B S-parameter test set.

HP 11851B 50 Ω Type-N RF Cable Set

This kit contains the three phase-matched 50 Ω type-N cables necessary to connect the HP 87512A/B transmission/reflection test kits or a power splitter to the analyzer. It also contains an RF cable used to return the transmitted signal of a two-port device to the network analyzer.

Adapters

HP 11852B 50 Ω to 75 Ω Minimum Loss Pad (DC to 2 GHz)

This device converts the impedance from 50 Ω (type-N, female) to 75 Ω (type-N, male) or from 75 Ω to 50 Ω . It provides a low SWR impedance match between a 75 Ω DUT and the analyzer or a 50 Ω measurement accessory. An HP 11852B pad is included with the HP 87512B 75 Ω transmission/reflection test kit. Three HP 11852B pads are included with the HP 11850D 75 Ω power splitter.

Adapter Kits

The following adapter kits contain the connection hardware required for making measurements on devices of the indicated connector type.

- HP 11853A 50 Ω Type-N Adapter Kit
- HP 11854A 50 Ω BNC Adapter Kit
- HP 11855A 75 Ω Type-N Adapter Kit
- HP 11856A 75 Ω BNC Adapter Kit

System accessories available

System rack The HP 85043B system rack is a 124 cm (49 inch) high metal cabinet designed to rack mount the analyzer in a system configuration. The rack is equipped with a large built-in work surface, a drawer for calibration kits and other hardware, a bookshelf for system manuals, and a locking rear door for secured access. Lightweight steel rails support the instrument along their entire depth. Heavy-duty casters make the cabinet easily movable even with the instruments in place. Screw-down lock feet permit leveling and semi-permanent installation. The cabinet is extremely stable when the lock feet are down. Power is supplied to the cabinet through a heavy-duty grounded primary power cable and to the individual instruments through special power cables included with the cabinet.

Printer The analyzer can output displayed measurement results directly to supported peripherals, not using external computers. Supported printers are as follows.

Table 9-1. Supported Printers and Printing Modes

Printer	Monochrome Printing	Fixed Color Printing	Variable Color Printing
HP DeskJet 340J	✓	✓	
HP DeskJet 505	✓		
HP DeskJet 560C	✓	✓	
HP DeskJet 850C	✓	✓	
HP DeskJet 1200	✓	✓	✓
HP DeskJet 1600CM	✓	✓	✓

HP-IB cable An HP-IB cable is required to interface the analyzer with a computer, or other external instrument. The following cables are available:

- HP 10833A (1 m)
- HP 10833B (2 m)
- HP 10833C (3 m)
- HP 10833D (0.5 m)

External Monitors The analyzer can control the built-in LCD and an external monitor simultaneously. Color monitors supporting VGA can be used as an external monitor.

Discs Hewlett-Packard disks are listed below.

- HP 92192A Box of 10 3.5 inch, 720 k byte micro flexible disks
- HP 92192X Box of 10 3.5 inch, 1.44M byte micro flexible disks

Specifications

These specifications are the performance standards or limits against which the instrument is tested. When shipped from the factory, the HP 4396B meets the specifications listed in this section. The performance test procedures are covered in the *HP 4396B Performance Test Manual*.

Specifications describe the instrument's warranted performance over the temperature range of 0°C to 40°C (except as noted). Supplemental characteristics are intended to provide information that is useful in applying the instrument by giving non-warranted performance parameters. These are denoted as *supplemental performance characteristics (s.p.c)*, *typical*, or *nominal*. Warm up time must be greater than or equal to 30 minutes after power on for all specifications.

Network Measurement

Source Characteristics

Frequency Characteristics

Range	100 kHz to 1.8 GHz
Resolution	≤1 mHz
Frequency reference	
Accuracy	
@23±5°C, referenced to 23°C	<±5.5 ppm/year
Aging	<±2.5 ppm/year (s.p.c)
Initial achievable accuracy	<±1.0 ppm (s.p.c)
Temperature stability	
@23±5°C, referenced to 23°C	<±2ppm (s.p.c)
Precision frequency reference (option 1D5)	
Accuracy	
@0°C to 40°C, referenced to 23°C	<±0.13 ppm/year
Aging	<±0.1 ppm/year (s.p.c)
Initial achievable accuracy	<±0.02 ppm (s.p.c)
Temperature stability	
@0°C to 40°C, referenced to 23°C	<±0.01 ppm (s.p.c)

Output Characteristics

Power range	-60 dBm to +20 dBm
Power sweep range	20 dB
Power sweep linearity	
@23±5°C, 50 MHz, relative to stop power	±0.5 dB
Resolution	0.1 dB
Flatness	
@23±5°C, relative to 50 MHz, 0 dBm output	±1.0 dB

Level accuracy

@23±5°C, 50 MHz, 0 dBm output <±0.5 dB

Level linearity

Output Power	Linearity ¹
-20 dBm ≤ power ≤ +20 dBm	±0.7 dB
-40 dBm ≤ power < -20 dBm	±1.0 dB
-60 dBm ≤ power < -40 dBm	±1.5 dB

¹ @23±5°C, relative to 0 dBm output

Spectral Purity Characteristics

Harmonics

@+15 dBm output <-30 dBc

Non-harmonics spurious

@+15 dBm output <-30 dBc

Noise sidebands

@ SPAN=0, IFBW (or RBW) ≤ 3 kHz

@ frequency ≤ 1 GHz

@ ≥10 kHz offset from carrier <-105 dBc/Hz (s.p.c)

@ ≥1 MHz offset from carrier <-110 dBc/Hz (s.p.c)

@ frequency > 1 GHz Add [20log(*frequency*(GHz))] (s.p.c)

Impedance 50 Ω nominal

Return loss

@ ≤0 dBm, 100 MHz < frequency ≤ 1.8 GHz >14 dB (s.p.c)

@ ≤0 dBm, 100 kHz ≤ frequency ≤ 100 MHz >23 dB (s.p.c)

Connector Type N female

Receiver Characteristics

Input Characteristics

Frequency range

@IFBW ≤ 3 kHz 100 kHz to 1.8 GHz

@IFBW = 10 kHz, 40 kHz 1 MHz to 1.8 GHz

Full scale input level

R input +20 dBm

A, B inputs -5 dBm

IF bandwidth (IFBW) 10, 30, 100, 300, 1 k, 3 k, 10 k, 40 kHz

Noise level

Frequency	Input Port	Noise Level @IFBW = 10 Hz	Noise Level @IFBW = 40 kHz
100 k ≤ freq. < 10 MHz	R	<-85 dBm	<-50 dBm
100 k ≤ freq. < 10 MHz	A, B	<-110 dBm	<-75 dBm
10 MHz ≤ freq.	R	<[-100 + 3 <i>f</i>] dBm ¹	<[-65 + 3 <i>f</i>] dBm ¹
10 MHz ≤ freq.	A, B	<[-125 + 3 <i>f</i>] dBm ¹	<[-90 + 3 <i>f</i>] dBm ¹

¹ *f* is measurement frequency (GHz).

Input crosstalk

@ ≥300 kHz

A to/from B <-100 dB

R to A, B <-120 dB

A, B to R <-80 dB

Source Crosstalk (A, B)

- @ ≥ 300 kHz < -124 dB (s.p.c)
- Maximum safe input level** $+20$ dBm or ± 25 Vdc (s.p.c)
- Connector** Type N female
- Impedance** 50Ω nominal
- Return loss**
- @frequency ≥ 500 kHz > 20 dB
- @ 100 kHz \leq frequency < 500 kHz > 12 dB (s.p.c)
- @ 3 MHz \leq frequency ≤ 50 MHz > 35 dB (s.p.c)
- Multiplexer switching impedance change $< 1 \Omega$ (s.p.c)

Magnitude Characteristics

Absolute amplitude accuracy (R, A, B)

- @ -20 dBm input, $23 \pm 5^\circ\text{C}$ $< \pm 1.5$ dB (± 0.9 dB (s.p.c))

Ratio accuracy (A/R, B/R)

- @ -20 dBm input, $23 \pm 5^\circ\text{C}$, IFBW ≤ 3 kHz
- @ 100 k \leq frequency < 1 MHz $< \pm 1$ dB (± 0.6 dB (s.p.c))
- @frequency ≥ 1 MHz $< \pm 0.5$ dB (± 0.3 dB (s.p.c))

Dynamic accuracy (A/R, B/R)

Input Level (relative to full scale input level) ¹	Dynamic Accuracy ²
0 dB	$< \pm 0.3$ dB
-10 dB to -70 dB	$< \pm 0.05$ dB
-80 dB	$< \pm 0.1$ dB
-90 dB	$< \pm 0.3$ dB
-100 dB	$< \pm 1.0$ dB
-110 dB	$< \pm 0.8$ dB (s.p.c)
-120 dB	$< \pm 2.5$ dB (s.p.c)

1 full scale input level = -5 dBm

2 @ $23 \pm 5^\circ\text{C}$, IFBW = 10 Hz, R input = -35 dBm, Reference power level = -35 dBm

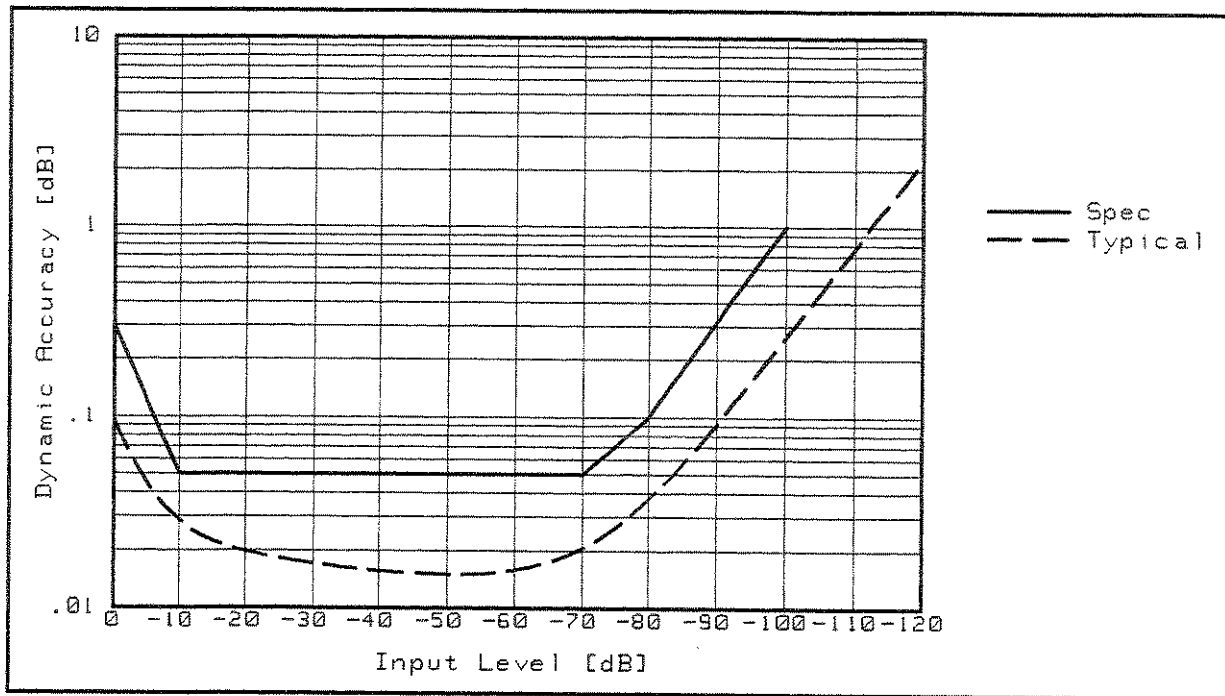

Figure 10-1. Magnitude Dynamic Accuracy

Residual responses

- @A, B inputs, frequency ≥ 3 MHz < -95 dBm (s.p.c)
- @R input, frequency ≥ 3 MHz < -70 dBm (s.p.c)
- See "EMC" under "Others" in "Common to Network and Spectrum Measurement".

Trace noise

- @A/R, B/R measurement, -10 dBm input, IFBW = 300 Hz < 0.002 dB rms (s.p.c)

- Stability** 0.01 dB/ $^{\circ}$ C (s.p.c)

Phase Characteristics

Measurements format Phase format, Expanded phase format

Frequency response (Deviation from Linear Phase) (A/R, B/R)

- @ -20 dBm input, $23 \pm 5^{\circ}$ C, IFBW ≤ 3 kHz
- $100 \text{ k} \leq$ frequency < 1 MHz $< \pm 6$ deg (± 4 deg (s.p.c))
- frequency ≥ 1 MHz $< \pm 3$ deg (± 2 deg (s.p.c))

Dynamic accuracy (A/R, B/R)

Input Level (relative to full scale input level) ¹	Dynamic Accuracy ²
0 dB	$< \pm 3$ deg
-10 dB	$< \pm 0.6$ deg
-20 dB to -70 dB	$< \pm 0.3$ deg
-80 dB	$< \pm 0.7$ deg
-90 dB	$< \pm 2.0$ deg
-100 dB	$< \pm 7$ deg
-110 dB	$< \pm 8$ deg (s.p.c)
-120 dB	$< \pm 25$ deg (s.p.c)

1 full scale input level = -5 dBm

2 @ $23 \pm 5^{\circ}$ C, IFBW = 10 Hz, R input = -35 dBm, Reference power level = -35 dBm

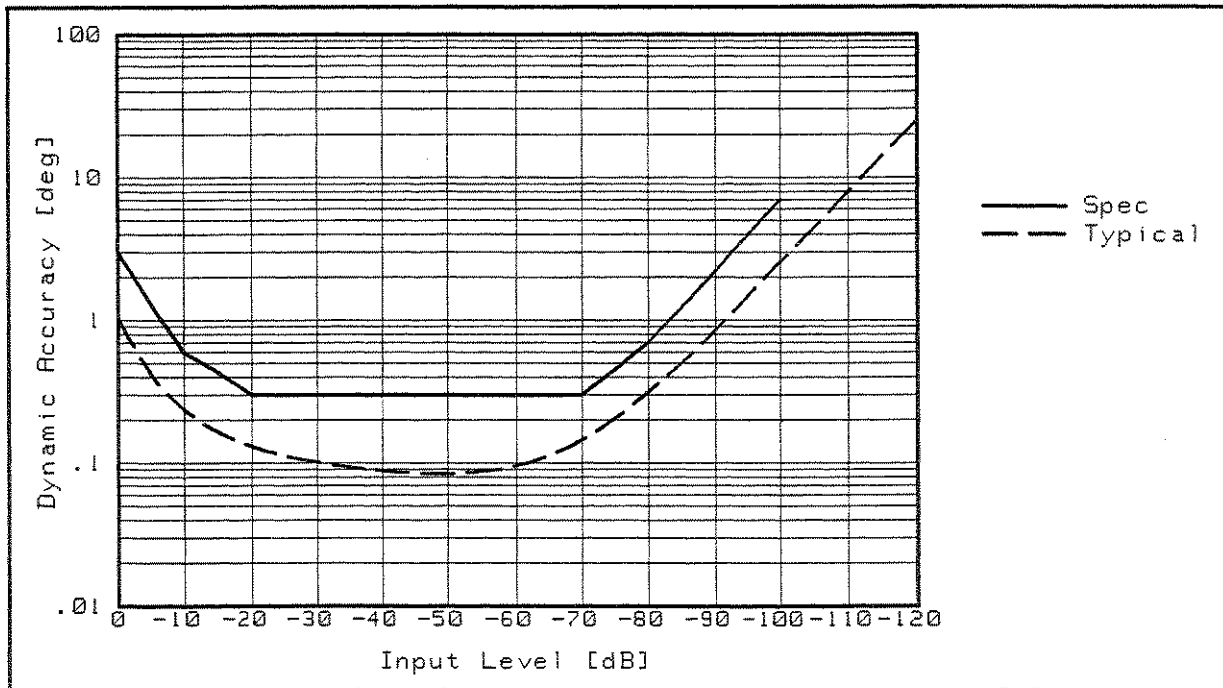

Figure 10-2. Phase Dynamic Accuracy

Trace noise

@A/R, B/R measurement, -10 dBm input, IFBW = 300 Hz <0.04 deg rms (s.p.c)

Stability 0.1 deg/°C (s.p.c)

Group Delay Characteristics

Accuracy

In general, the following formula can be used to determine the accuracy, in seconds, of a specific group delay measurement:

@23±5°C $\frac{\text{Phase Accuracy (deg)}}{\text{Aperture (Hz)} \times 360 \text{ deg}}$

Depending on the aperture, input level, and device length, the phase accuracy used in either incremental phase accuracy or worst case phase accuracy.

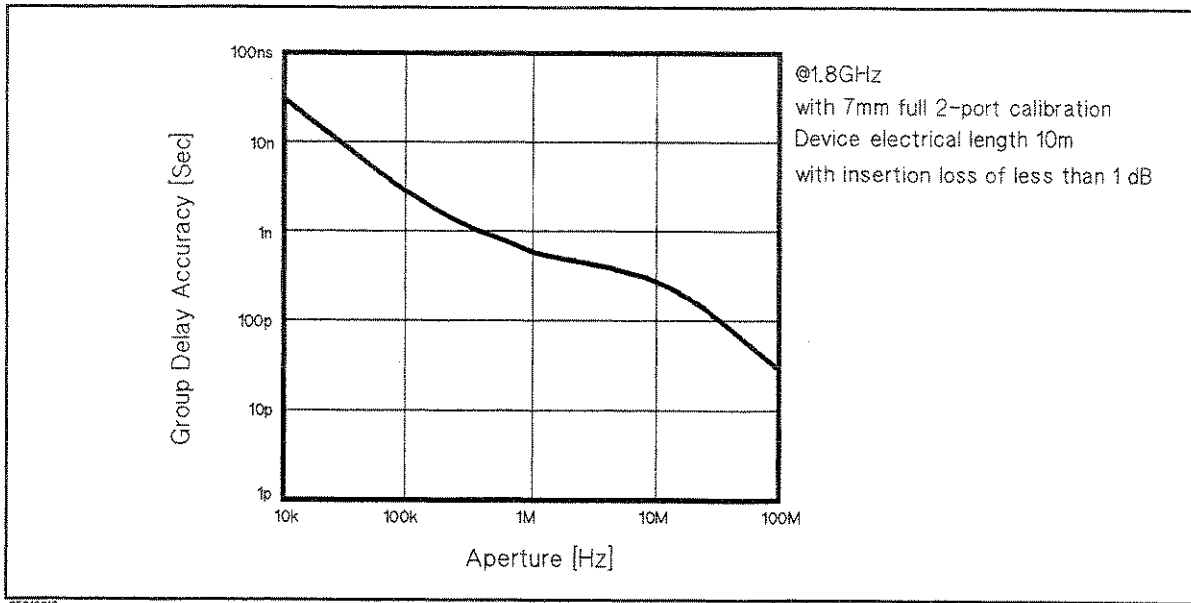

Figure 10-3. Typical Group Delay Accuracy

Sweep Characteristics

Sweep type linear frequency, log frequency, power, list frequency

Trigger type hold, single, number of groups, continuous

Trigger source free run, external, manual, HP-IB (bus)

Event trigger On point, On sweep

Spectrum Measurement

Specifications in this section describe the instrument's warranted performance for spectrum measurement using S input (except as noted).

Frequency Characteristics

Frequency range 2 Hz to 1.8 GHz
Frequency readout accuracy $\pm((freq\ readout) \times (freq\ ref\ accuracy) + RBW + \frac{SPAN}{NOP})$

where NOP means number of display points

Frequency reference

Accuracy

@23±5°C, referenced to 23°C <±5.5 ppm/year

Aging <±2.5 ppm/year (s.p.c)

Initial achievable accuracy <±1 ppm (s.p.c)

Temperature stability

@23±5°C, referenced to 23°C <±2 ppm (s.p.c)

Precision frequency reference (option 1D5)

Accuracy

@0°C to 40°C, referenced to 23°C <±0.13 ppm/year

Aging <±0.1 ppm/year (s.p.c)

Initial achievable accuracy <±0.02 ppm (s.p.c)

Temperature stability

@0°C to 40°C, referenced to 23°C <±0.01 ppm (s.p.c)

Resolution bandwidth (RBW)

Range 1 Hz to 3 MHz, 1-3-10 step

Selectivity (60 dB BW / 3 dB BW)

@RBW ≥ 10 kHz <10

@RBW ≤ 3 kHz <3

Accuracy

@RBW ≥ 10 kHz <±20%

@RBW ≤ 3 kHz <±10%

Video bandwidth

Range 0.003 Hz to 3 MHz, 1-3-10 step, $1 \leq RBW/VBW \leq 300$

Noise sidebands

Offset from Carrier	Noise Sidebands ¹
>1 kHz	<-95 dBc/Hz
>10 kHz	<-105 dBc/Hz
>1 MHz	<-110 dBc/Hz

¹ Center frequency ≤ 1 GHz. Add $[20\log(\text{frequency}(GHz))]$ for frequency > 1 GHz.

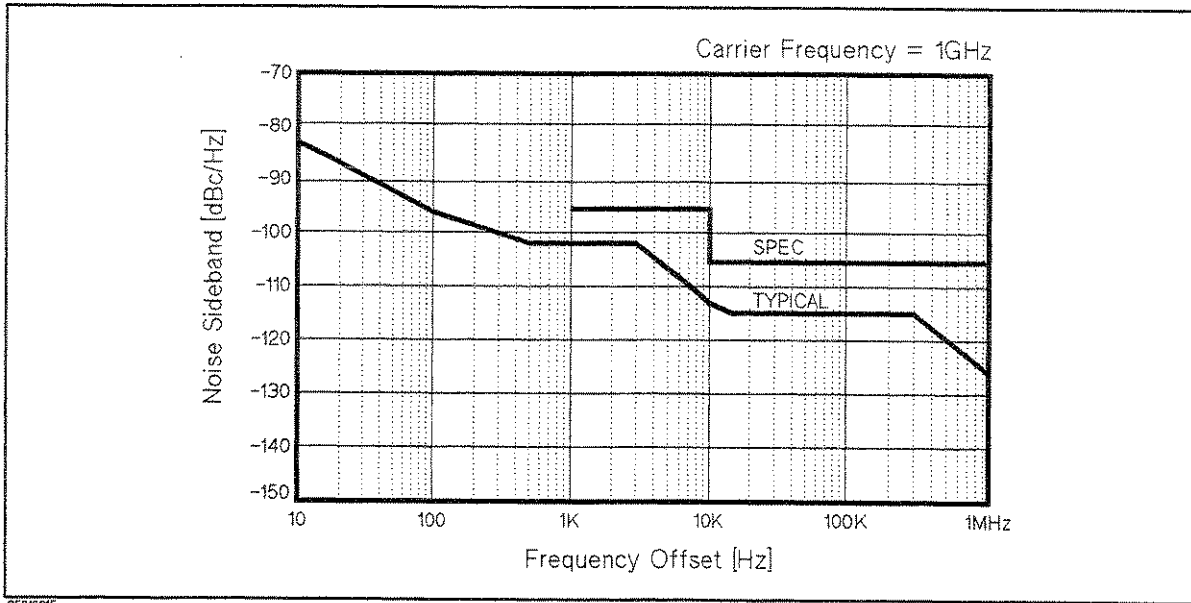

Figure 10-4. Typical Noise Sidebands (with option 1D5)

Residual FM

@RBW ≤ 10 Hz

Standard $< 1 \times f(GHz)$ Hz_{pk-pk} in 10 sec (s.p.c)

(@frequency = 1 GHz < 1 Hz_{pk-pk} (s.p.c))

Option 1D5 $< 0.1 \times f(GHz)$ Hz_{pk-pk} in 10 sec (s.p.c)

(@frequency = 1 GHz < 0.1 Hz_{pk-pk} (s.p.c))

@RBW ≤ 1 kHz < 3 Hz_{pk-pk} in 100 msec (s.p.c)

On-screen dynamic range

@ 1 GHz Center frequency, May be limited by average noise level.

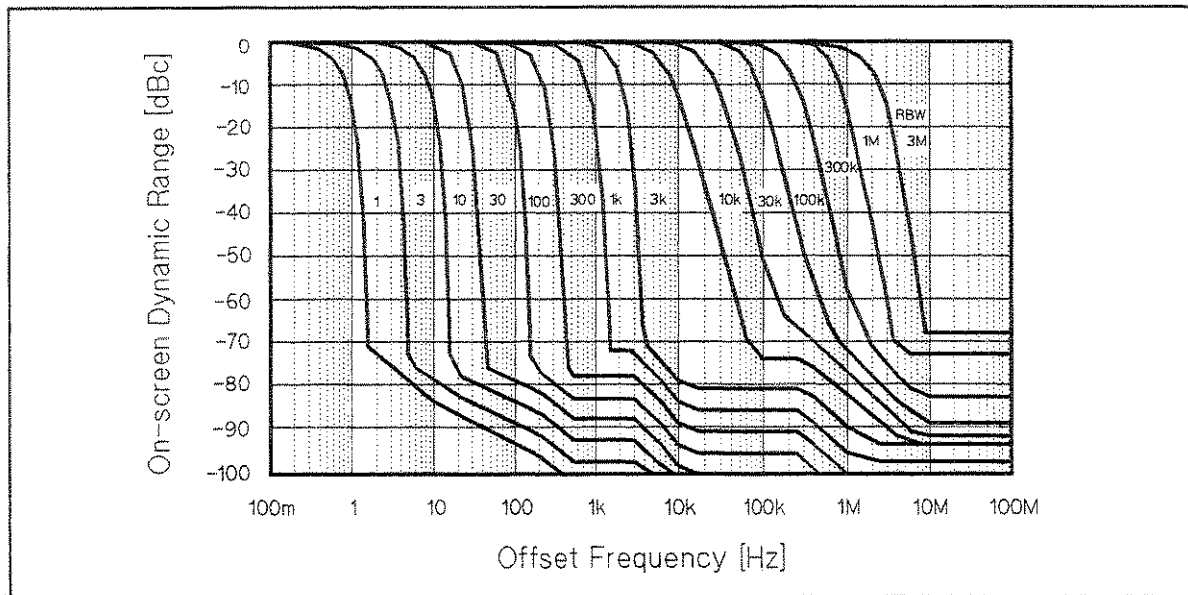

Figure 10-5. Typical On-screen Dynamic Range

Amplitude Characteristics

- Amplitude range** Displayed average noise level to +30 dBm
- Reference level range** -100 dBm to +30 dBm
(or equivalent in dB μ V, dBV, V, W)
- Scale**
- Log** 0.1 dB/div to 20 dB/div
- Linear**
- @Watt 1.0×10^{-12} W/div
- @Volt 1.0×10^{-9} V/div
- Measurement format** SPECTRUM or NOISE(/HZ)
- Display unit** dBm, dB μ V, dBV, Volts, Watts

Typical dynamic range

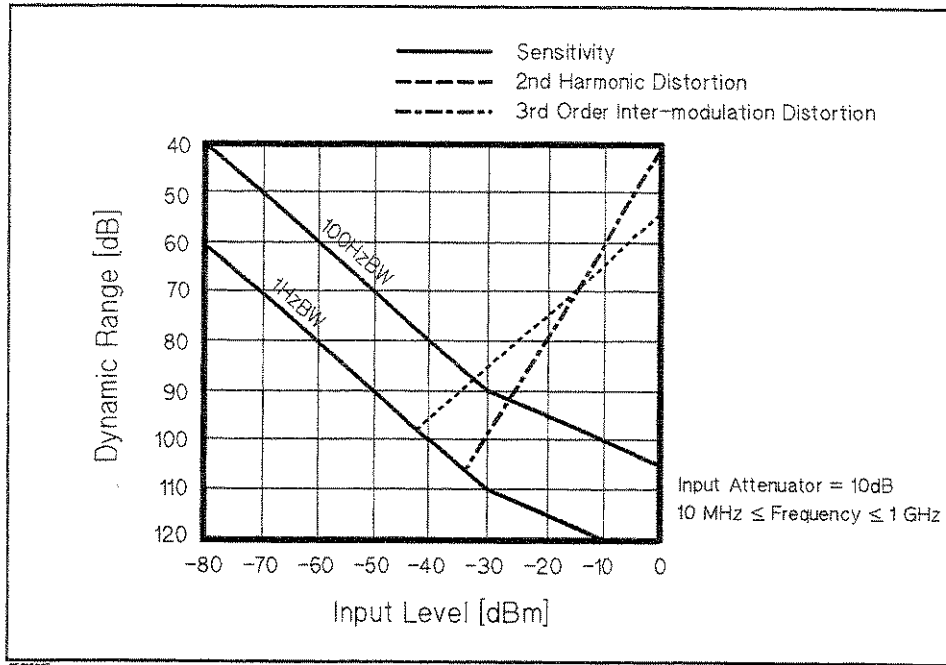

Figure 10-6. Typical Dynamic Range at S input

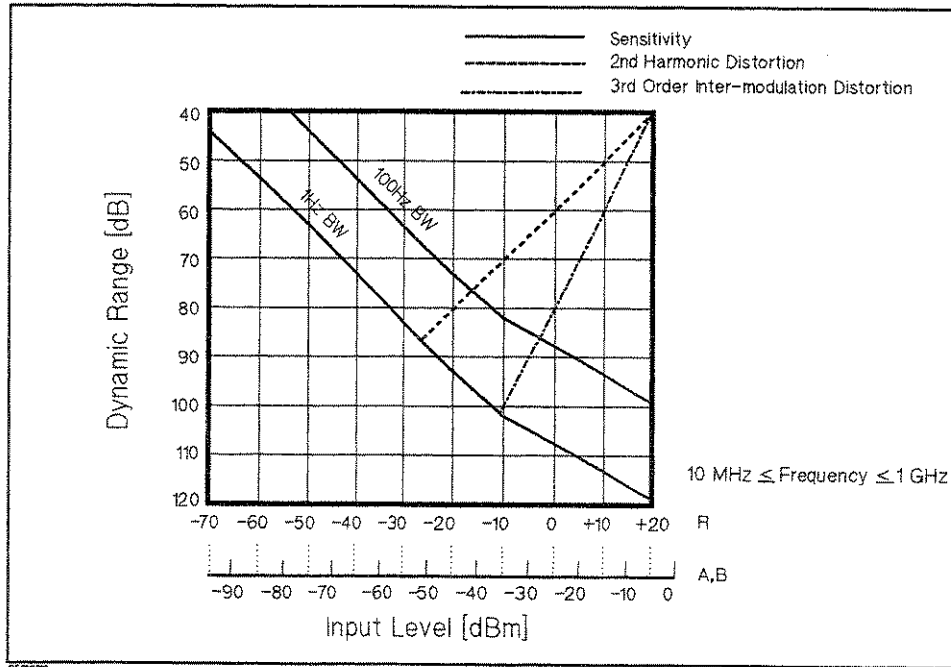

Figure 10-7. Typical Dynamic Range at R, A, and B inputs

Spurious responses

Second harmonic distortion

- @ ≥ 10 MHz, -35 dBm mixer input <-70 dBc
- @<10 MHz, -35 dBm mixer input <-60 dBc

Third order inter-modulation distortion

- @each input mixer level of two tones = -30 dBm, separation ≥ 20 kHz
- @ ≥ 10 MHz <-75 dBc
- @<10 MHz <-65 dBc

Other spurious

- @-30 dBm mixer input, offset ≥ 1 kHz <-70 dBc

Residual response

- @ ≥ 3 MHz, 0 dB attenuator <-100 dBm
- @1 kHz \leq frequency < 3 MHz, 0 dB attenuator <-90 dBm
- See "EMC" under "Others" in "Common to Network and Spectrum Measurement".

Local oscillator feedthrough <-25 dBm input mixer level equivalent (s.p.c)

Gain compression

- @ ≥ 10 MHz, input mixer level ≤ -10 dBm <0.3 dB (s.p.c)

Displayed average noise level

- @frequency ≥ 10 MHz, ref. level ≤ -40 dBm, att. = 0 dB <[-150 + 3f(GHz)] dBm/Hz
- @10 kHz \leq frequency < 10 MHz, ref. level ≤ -40 dBm, att. = 0 dB <-125 dBm/Hz

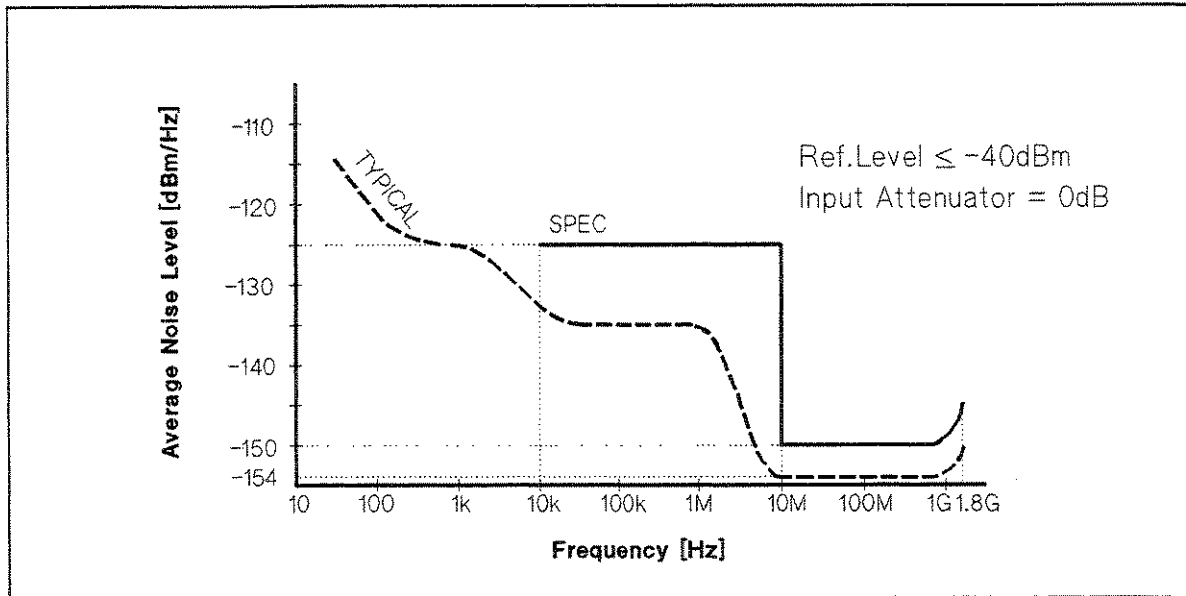

Figure 10-8. Typical Displayed Average Noise Level

Maximum safe input level

- Average continuous power +30 dBm (1W)
- Peak pulse power
- @pulse width < 10 μ s, duty cycle < 1%, input attenuator ≥ 30 dB +50 dBm (100 W)
- dc voltage 0 Vdc

Input attenuator

- Range 0 dB to 60 dB, 10 dB step

Level accuracy

- Calibrator accuracy (-20 dBm 20MHz) < ± 0.4 dB (± 0.2 dB (s.p.c))

Frequency response

@23±5°C, att. = 10 dB, referenced to level at 20 MHz

- 10 MHz ≤ frequency ≤ 1.8 GHz <±0.5 dB (±0.3 dB (s.p.c))
- 2 Hz ≤ frequency < 10 MHz <±1.5 dB (±0.8 dB (s.p.c))

Amplitude fidelity

Log scale

Range (dB from Ref. Level)	Amplitude Fidelity ¹ @1 Hz ≤ RBW ≤ 3 kHz		Amplitude fidelity ¹ @10 kHz ≤ RBW ≤ 300 kHz		Amplitude fidelity ¹ @1 MHz ≤ RBW ≤ 3 MHz	
	Spec.	Typical	Spec.	Typical	Spec.	Typical
0 dB ≥ range ≥ -30 dB	±0.05 dB	±0.02 dB	±0.3 dB	±0.12 dB	±1.0 dB	±0.4 dB
-30 dB > range ≥ -40 dB	±0.07 dB	±0.03 dB	±0.3 dB	±0.12 dB	±1.0 dB	±0.4 dB
-40 dB > range ≥ -50 dB	±0.12 dB	±0.05 dB	±0.4 dB	±0.15 dB	±1.2 dB	±0.5 dB
-50 dB > range ≥ -60 dB	±0.4 dB	±0.12 dB	±0.7 dB	±0.3 dB	±1.4 dB	±0.6 dB
-60 dB > range ≥ -70 dB	±1.2 dB	±0.8 dB	±1.5 dB	±0.6 dB	±2.2 dB	±0.8 dB
-70 dB > range ≥ -80 dB	±4 dB	±1 dB	±4.3 dB	±1.2 dB	-	-
-80 dB > range ≥ -90 dB	-	±3 dB	-	-	-	-
-90 dB > range ≥ -100 dB	-	±10 dB	-	-	-	-

1 @23±5°C, -10 dBm ≥ [ref. level - input att] ≥ -50 dBm except for gain compression

For small signal measurement, fidelity is degraded by noise floor according to below formula:

$$20 \log_{10}(1 \pm 10^{-\frac{x}{20}} \times 3.5) \text{ dB (s.p.c)}$$

where, x is signal to noise floor ratio in dB.

This fidelity error can be reduced by narrower video bandwidth or sweep averaging.

Linear scale

@23±5°C, -10 dBm ≥ [ref level - input att] ≥ -50 dBm except for gain compression

- @RBW ≤ 300 kHz <±3% of reference level
- @RBW ≥ 1 MHz <±10% of reference level

IF gain switching uncertainty

@ input att. fixed, referenced to -20 dBm [ref. level - input att] <±0.3 dB

Input attenuator switching uncertainty

- @20 dB to 40 dB, referenced to 10 dB <±1.0 dB
- @50 dB to 60 dB, referenced to 10 dB <±1.5 dB

RBW switching uncertainty

@SPAN < 100 × RBW for RBW ≥ 10 kHz, 23±5°C, referenced to 10 kHz RBW <±0.5 dB

Temperature drift

- S input 0.05 dB/°C (s.p.c)
- R, A, B inputs 0.1 dB/°C (s.p.c)

Sweep Characteristics

Sweep type linear, zero span, list
Trigger type hold, single, number of groups, continuous
Trigger source free run, external, video, manual, gate
Sweep time

RBW	SPAN	Typical Sweep Time
3 MHz	1.8 GHz	40 ms
1 MHz	1 GHz	60 ms
300 kHz	1 GHz	340 ms
100 kHz	100 MHz	100 ms
30 kHz	100 MHz	460 ms
10 kHz	10 MHz	400 ms
3 kHz	10 MHz	2.4 s
1 kHz	1 MHz	651 ms
300 Hz	1 MHz	3 s
100 Hz	100 kHz	1.4 s
30 Hz	100 kHz	3.2 s
10 Hz	10 kHz	1.5 s
3 Hz	10 kHz	12 s
1 Hz	1 kHz	11 s
—	Zero Span	— ¹

¹ See the next item for sweep time at zero span

Zero span

Normal Zero Span $\geq 25 \mu\text{s}/\text{display point}$
 Repetitive Zero Span $\geq 0.5 \mu\text{s}/\text{display point}$

Number of display points

@span \neq zero

@RBW ≥ 10 kHz

@Sweep time = auto 801 points (fixed)

@Sweep time = manual ≤ 801 points (automatically set)

@RBW ≤ 3 kHz ≤ 801 points (automatically set)

@span = zero 2 to 801 points (selectable)

Input and Output Characteristics

RF input

Connector Type N female

Impedance 50 Ω nominal

Return Loss

@S input

@>50 MHz, input att. \geq 10 dB >14 dB (s.p.c)

@ \leq 50 MHz, input att. \geq 10 dB >25 dB (s.p.c)

@R, A, B inputs same as network measurement.

Coupling

S input DC

R, A, B inputs AC

Crosstalk

@S Input, input att = 10 dB

S input to A, B inputs < -30 dB (s.p.c)

A, B inputs to S input < -22 dB (s.p.c)

Cal output

Connector BNC female

Impedance 50 Ω

Output Frequency 20 MHz

Output Level -20 dBm \pm 0.4 dB

Return Loss > 26 dB (s.p.c)

Specifications when Option 1D6 Time-Gated spectrum analysis is installed

Gate length
Range 2 μ s to 3.2 s
Resolution

Range of Gate Length(T_g)	Resolution
$2 \mu\text{s} \leq T_g \leq 32 \text{ ms}$	0.5 μs
$32 \text{ ms} < T_g \leq 64 \text{ ms}$	1 μs
$64 \text{ ms} < T_g \leq 160 \text{ ms}$	2.5 μs
$160 \text{ ms} < T_g \leq 320 \text{ ms}$	5 μs
$320 \text{ ms} < T_g \leq 1.28 \text{ s}$	20 μs
$1.28 \text{ ms} < T_g \leq 3.2 \text{ s}$	100 μs

Gate delay
Range 2 μ s to 3.2 s
Resolution

Range of Gate Delay (T_d)	Resolution
$2 \mu\text{s} \leq T_d \leq 32 \text{ ms}$	0.5 μs
$32 \text{ ms} < T_d \leq 64 \text{ ms}$	1 μs
$64 \text{ ms} < T_d \leq 160 \text{ ms}$	2.5 μs
$160 \text{ ms} < T_d \leq 320 \text{ ms}$	5 μs
$320 \text{ ms} < T_d \leq 1.28 \text{ s}$	20 μs
$1.28 \text{ ms} < T_d \leq 3.2 \text{ s}$	100 μs

Additional Amplitude Error

Log scale < 0.3 dB (s.p.c)
Linear scale < 3% (s.p.c)
Gate Control Modes Edge pos, Edge neg, or Level
Gate Trigger Input (External Trigger Input is used)
Connector BNC female
Trigger level TTL Level
Gate Output
Connector BNC female
Output level TTL Level

Specifications when Option 1D7 50 Ω to 75 Ω Input Impedance Conversion

All specifications are identical to the standard HP 4396B except the following items.

Amplitude range Displayed average noise level to 24 dBm
Displayed average noise level
 @ ≥ 10 MHz < [-148 + 3f(GHz)] dBm/Hz (s.p.c)
Level accuracy
 @ 20 MHz, after level cal < ± 0.4 dB (s.p.c)
Frequency response
 @ input attenuator = 10 dB < ± 0.5 dB (s.p.c)

HP 4396B Option 010 Specifications

Measurement Functions

Measurement parameters	Z, Y, L, C, Q, R, X, G, B, θ
Display parameters	$ Z , \theta_z, R, X, Y , \theta_y, G, B, \Gamma , \theta_\gamma, \Gamma_x, \Gamma_y, C_p, C_s, L_p, L_s, R_p, R_s, D, Q$

Display Formats

- Vertical lin/log scale
- Complex plane
- Polar/Smith/admittance chart

Sweep Parameters

- Linear frequency sweep
- Logarithmic frequency sweep
- List frequency sweep
- Linear power sweep (dBm)

IF Bandwidth

10, 30, 100, 300, 1k, 3k, 10k, 40k [Hz]

Calibration

- OPEN/SHORT/LOAD 3 term calibration
- Fixture compensation
- Port extension correction

Unknown Port

- APC-7 connector

Output Characteristics

Frequency range 100 kHz to 1.8 GHz

Frequency resolution 1 mHz

Output Level -60 to +20 dBm (@RF OUT port)

Note: Signal level at the measurement port is 6 dB lower than the RF OUT port when the measurement port is terminated by 50 Ω .

Output level accuracy $A + B + 6$ [dB] $\times F / (1.8 \times 10^9)$

Where,

$$A = 2 \text{ dB } (\pm 5^\circ \text{C})$$

$$B = 0 \text{ dB } (\text{OSC} \leq 0 \text{ dBm}), \text{ or } 1 \text{ dB } (-40 \leq \text{OSC} < 0 \text{ dBm}), \text{ or } 2 \text{ dB } (-60 \leq \text{OSC} < -40 \text{ dBm})$$

F is output frequency.

Output level resolution 0.1 dB
Measurement port impedance Nominal 50 Ω

External DC Bias Input

Maximum voltage ± 40 V
Maximum current 20 mA

* 2 k Ω \pm 5% resistor is inserted for DC bias current limitation.

Measurement Basic Accuracy (Supplemental Performance Characteristics)

Measurement accuracy is specified at the connecting surface of the APC-7 connector of the HP 43961A under the following conditions:

Warm up time > 30 minutes
Ambient Temperature 23 °C \pm 5°C
(@same temperature at which calibration was performed.)
Signal level (@ 50 Ω Terminated) -6 to 14 dBm
Correction ON
IFBW \leq 300 Hz
Averaging (cal) \geq 8

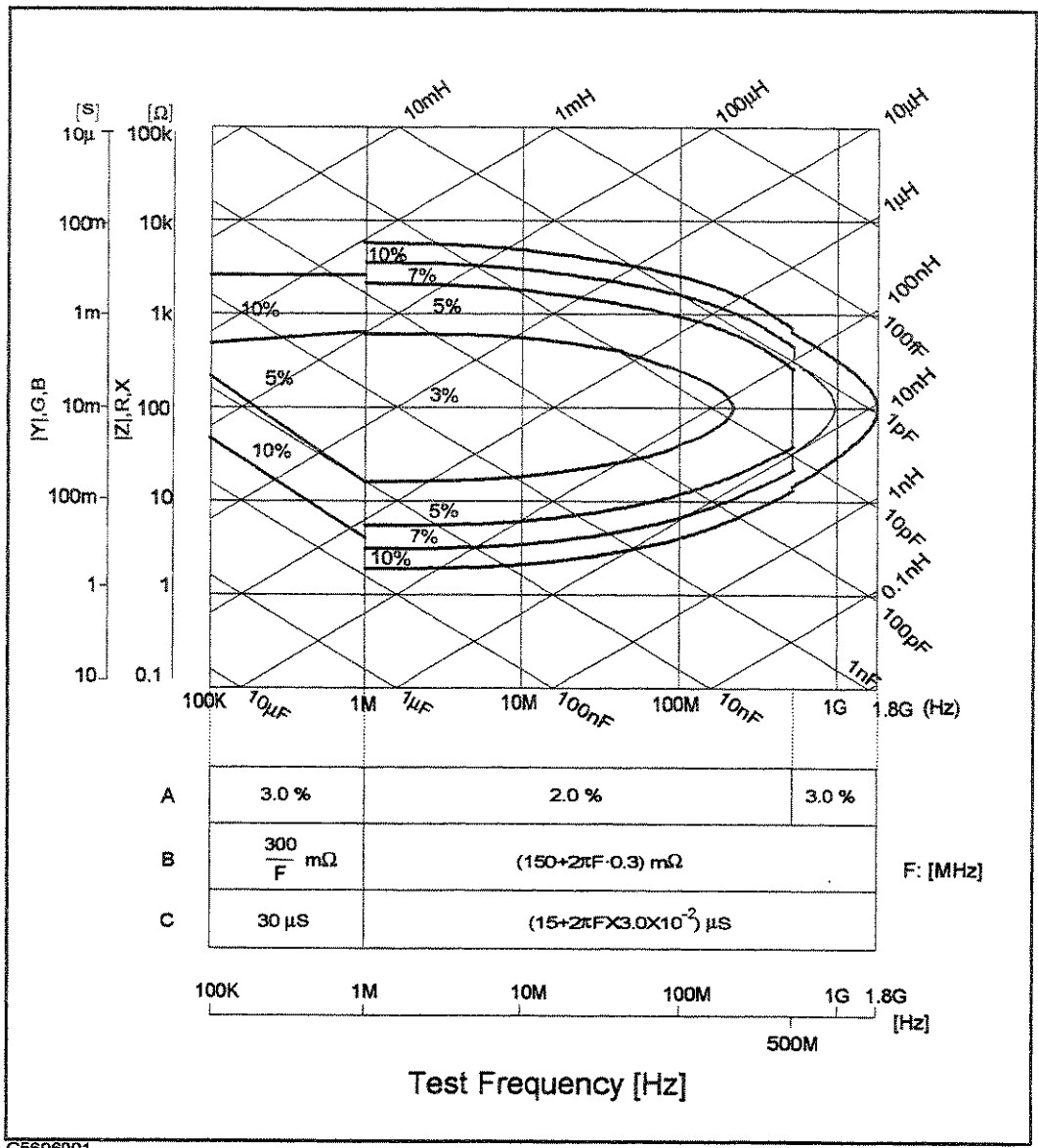

C5606001

Figure 10-9. Impedance Measurement Accuracy

|Z| - θ Accuracy

|Z| accuracy $Z_a = A + (B/|Z_m| + C \times |Z_m|) \times 100 [\%]$

θ accuracy $\theta_a = \sin^{-1}(Z_a/100)$

Where, |Z_m| is |Z| measured. A, B, and C are obtained from Figure 10-9.

|Y| - θ Accuracy

|Y| accuracy $Y_a = A + (B \times |Y_m| + C/|Y_m|) \times 100 [\%]$

θ accuracy $\theta_a = \sin^{-1}(Y_a/100)$

Where, $|Y_m|$ is |Y| measured. A, B, and C are obtained from Figure 10-9.

R - X Accuracy (Depands on D)

Accuracy	$D \leq 0.2$	$0.2 < D \leq 5$	$5 < D$
R_a	$\pm X_m \times X_a/100 [\Omega]$	$R_a/\cos\theta [\%]$	$R_a [\%]$
X_a	$X_a [\%]$	$X_a/\sin\theta [\%]$	$\pm R_m \times R_a/100 [\Omega]$

Where,

D can be calculated as: R/X , or
 $R/(2\pi f \times L_s)$, or
 $R \times 2\pi f \times C_s$

θ can be calculated as: $\tan^{-1}(X/R)$, or
 $\tan^{-1}(2\pi f \times L_s/R)$, or
 $\tan^{-1}(1/(R \times 2\pi f \times C_s))$

$R_a = A + (B/|R_m| + C \times |R_m|) \times 100 [\%]$

$X_a = A + (B/|X_m| + C \times |X_m|) \times 100 [\%]$

R_m and X_m are the measured R and X, respectively. A, B, and C are obtained from Figure 10-9.

G - B Accuracy (Depands on D)

Accuracy	$D \leq 0.2$	$0.2 < D \leq 5$	$5 < D$
G_a	$\pm B_m \times B_a/100 [S]$	$G_a/\cos\theta [\%]$	$G_a [\%]$
B_a	$B_a [\%]$	$B_a/\sin\theta [\%]$	$\pm G_m \times G_a/100 [S]$

Where,

D can be calculated as: G/B , or
 $G/(2\pi f \times C_p)$, or
 $G \times 2\pi f \times L_p$

θ can be calculated as: $\tan^{-1}(B/G)$, or
 $\tan^{-1}(2\pi f \times C_p/G)$, or
 $\tan^{-1}(1/(G \times 2\pi f \times L_p))$

$G_a = A + (B/|G_m| + C \times |G_m|) \times 100 [\%]$

$B_a = A + (B/|B_m| + C \times |B_m|) \times 100 [\%]$

G_m and B_m are the measured G and B , respectively. A , B , and C are obtained from Figure 10-9.

D Accuracy

Accuracy	$D \leq 0.2$	$0.2 < D$
D_a	$Z_a/100$	$(Z_a/100) \times (1 + D^2)$

Where, Z_a is $|Z|$ accuracy.

L Accuracy (Depends on D)

Accuracy	$D \leq 0.2$	$0.2 < D$
L_a	$L_a/100$	$L_a(1 + D)$

Where, $L_a = A + (B/|Z_l| + C \times |Z_l|) \times 100$ [%]

$|Z_l| = 2\pi f \times L_m$, f is frequency in Hz, and L_m is measured L . A , B , and C are obtained from Figure 10-9.

C Accuracy (Depends on D)

Accuracy	$D \leq 0.2$	$0.2 < D$
C_a	C_a	$C_a(1 + D)$

Where, $C_a = A + (B/|Z_c| + C \times |Z_c|) \times 100$ [%]

$|Z_c| = 2\pi f \times C_m$, f is frequency in Hz, and C_m is measured C . A , B , and C are obtained from Figure 10-9.

Common to Network and Spectrum Measurement

Display

LCD

Size/Type	8.4 inch color LCD
Resolution	640 × 480
Effective Display Area	160 mm × 115 mm(600 × 430 dots)
Number of display channels	2
Format	single, dual split or overwrite, graphic, and tabular
Number of traces	
For measurement	2 traces
For memory	2 traces
Data math	$gain \times data - offset,$ $gain \times memory - offset,$ $gain \times (data - memory) - offset,$ $gain \times (data + memory) - offset,$ $gain \times (data/memory) - offset$
Data hold	Maximum hold, Minimum hold

Marker

Number of markers

Main marker	1 for each channel
Sub-marker	7 for each channel
Δmarker	1 for each channel

Storage

Type	Built-in flexible disk drive, Volatile RAM disk memory
Disk format	LIF, DOS

HP-IB

Interface	IEEE 488.1-1987, IEEE 488.2-1987, IEC 625, and JIS C 1901-1987 standards compatible.
Interface function	SH1, AH1, T6, TE0, L4, LE0, SR1, RL1, PP0, DC1, DT1, C1, C2, C3, C4, C11, E2
Data transfer formats	ASCII, 32 and 64 bit IEEE 754 Floating point format, DOS PC format (32 bit IEEE with byte order reversed)

Parallel interface

Interface	Centronics standard compliant
Printer control language	HP PCL3 Printer Control Language

Probe Power

Output voltage +15 V (300 mA), -12.6 V (160 mA), GND nominal

Specifications When HP Instrument BASIC Is Operated

Keyboard PS/2 style 101 english keyboard
 Connector mini-DIN
 I/O port 4 bit in / 8 bit out port, TTL Level

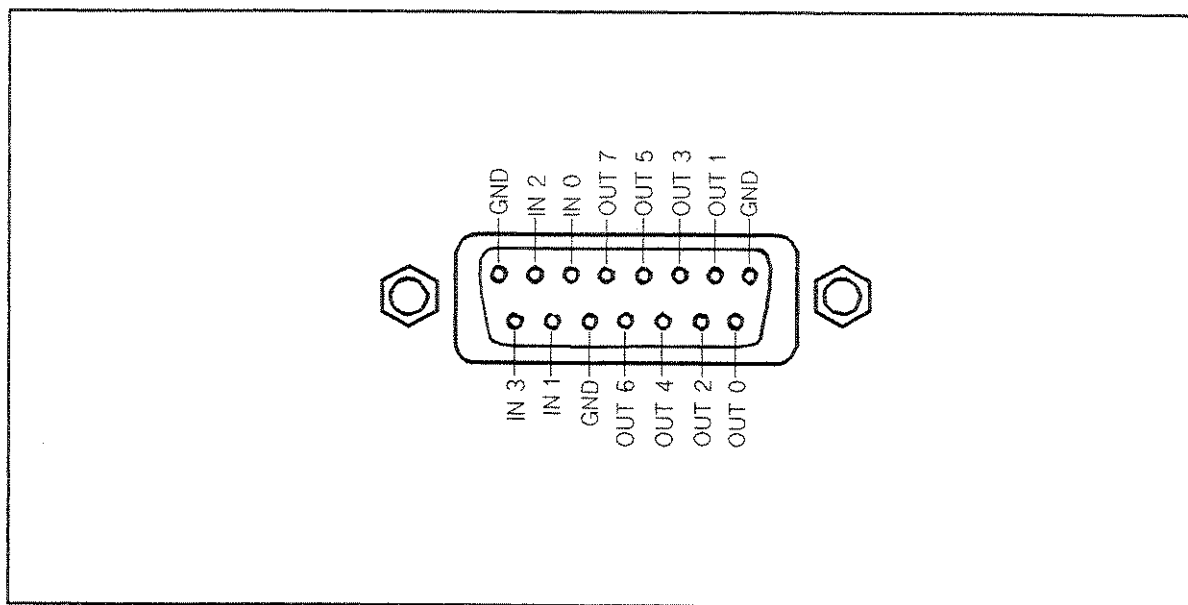

Figure 10-10. I/O Port Pin Assignments

General Characteristics

Input and Output Characteristics

External reference input

Frequency 10 MHz \pm 100 Hz (s.p.c)
 Level $>$ -6 dBm (s.p.c)
 Input impedance 50 Ω nominal
 Connector BNC female

Internal Reference Output

Frequency 10 MHz nominal
 Level 2 dBm (s.p.c)
 Output Impedance 50 Ω nominal
 Connector BNC female

Reference oven output (Option 1D5)

Frequency 10 MHz nominal
 Level 0 dBm (s.p.c)
 Output impedance 50 Ω nominal
 Connector BNC female

2nd IF output

Frequency 21.42 MHz nominal
 output impedance 50 Ω nominal

Connector	BNC female
External trigger input	
Level	TTL Level
Pulse width (T_p)	$\geq 2 \mu\text{s}$ (s.p.c)
Polarity	positive/negative selective
Connector	BNC female
External program Run/Cont input	
Connector	BNC female
Level	TTL Level
Gate output (Option 1D6)	
Level	TTL Level
Connector	BNC female

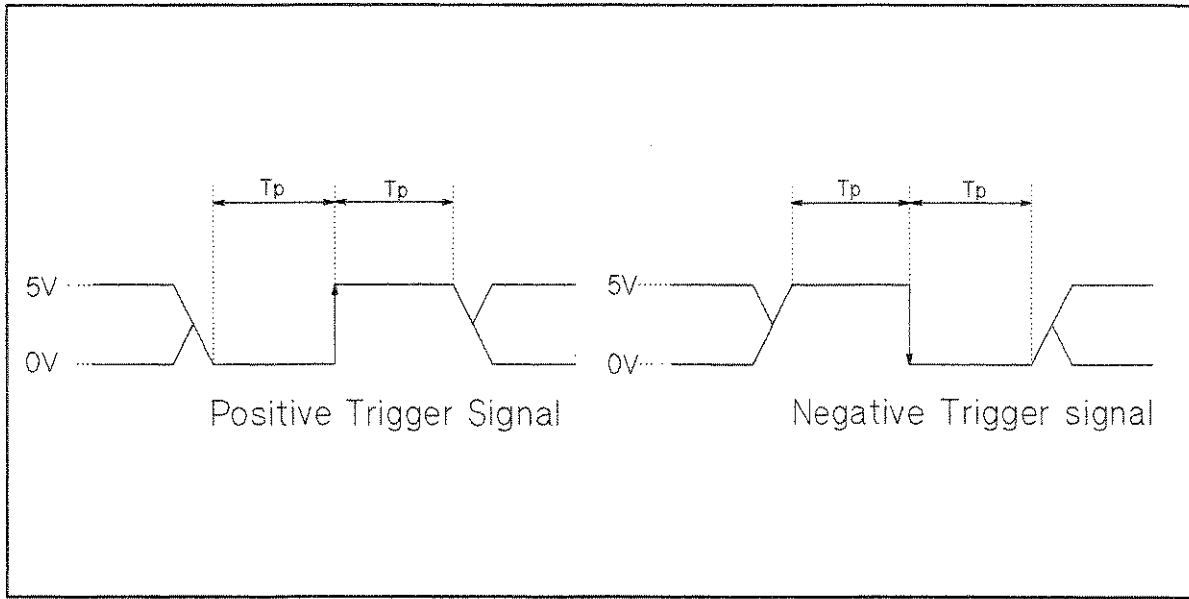

C5010014

Figure 10-11. Trigger Signal

S-parameter test set interface

Connector D-SUB (25 pin)

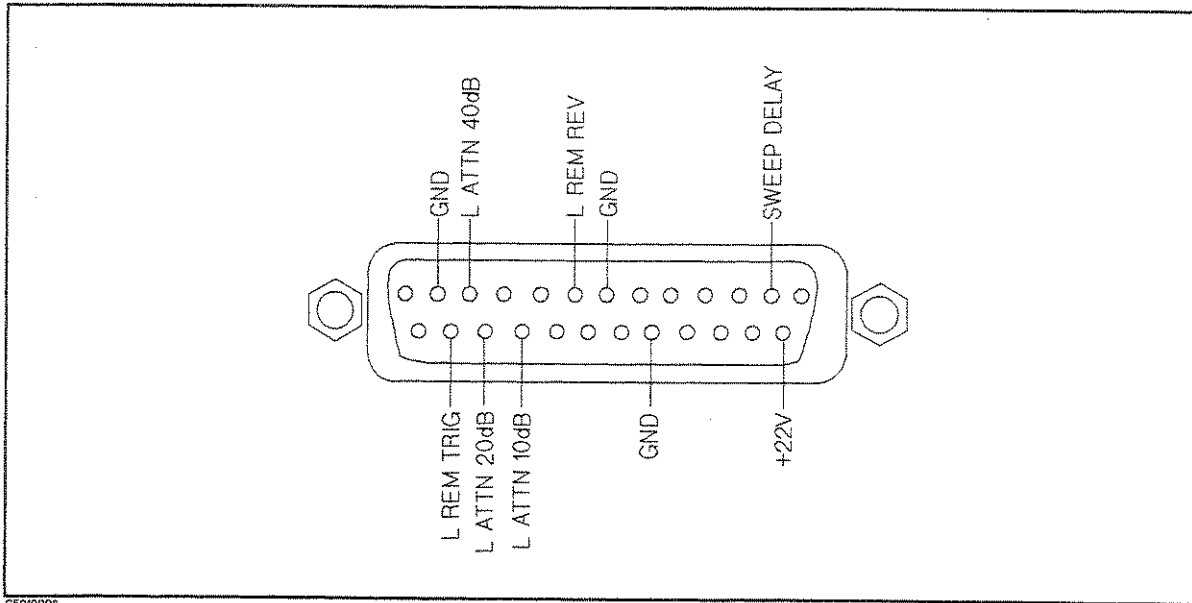

Figure 10-12. S-Parameter Test Set Interface Pin Assignments

External monitor output

Connector D-SUB 15-pin HD

Display resolution 640 × 480 VGA

Operation Conditions

Temperature

Disk drive non-operating condition 0°C to 40°C

Disk drive operating condition 10°C to 40°C

Humidity

@wet bulb temperature $\leq 29^\circ\text{C}$, without condensation

Disk drive non-operating condition 15% to 95% RH

Disk drive operating condition 15% to 80% RH

Altitude 0 to 2000 meters

Warm up time 30 minutes

Non-operation Conditions

Temperature -20°C to 60°C

Humidity

@wet bulb temperature $\leq 45^\circ\text{C}$, without condensation 15% to 95% RH

Altitude 0 to 4572 meters

Others

EMC Complies with CISPR 11 (1990) / EN 55011 (1991) : Group 1, Class A
 Complies with IEC 1000-3-2 (1995) / EN 6100-3-2 (1995)
 Complies with IEC 1000-3-3 (1994) / EN 6100-3-3 (1995)
 Complies with IEC 1000-4-2 (1995) / EN 50082-1 (1992) : 4 kV CD, 8 kV AD
 Complies with IEC 801-3 (1984) / EN 50082-1 (1992) : 3 V/m
 Complies with IEC 1000-4-4 (1995) / EN 50082-1 (1992) : 1 kV / Main, 0.5kV / Singnal Line

Note: When tested at 3 V/m according to IEC 801-3/1984, the residual response will be within specifications over the full immunity test frequency range of 27 MHz to 1000 MHz except when the analyzer frequency is identical to the transmitted interference signal test frequency.

Power requirements 90 V to 132 V, or 198 V to 264 V, 47 to 63 Hz, 300 VA max
 Weight 21.5 kg max
 Dimensions 425(W) × 235(H) × 553(D) mm

Furnished Accessories

Accessory	HP part number	Accessory	HP part number
Task Reference	04396-90030	Power Cable ²	
User's Guide	04396-90031	BNC Adapter ³	1250-1859
Function Reference	04396-90032	50 to 75 Ω minimum loss pad ⁴	HP 11825B option C04
Programming Guide	04396-90033	50 to 75 Ω adapter ⁴	1250-2438
HP-IB Command Reference	04396-90034	Keyboard	C3757-60401
Performance Test Manual	04396-90130	Handle Kit ⁵	5062-3991
Service Manual	04396-90101 ¹	Rack Mount Kit ⁶	5062-3979
Sample Program Disk	04396-61002	Rack Mount and Handle Kit ⁷	5062-3985
Floppy Disk	9164-0299	HP Instrument BASIC Users Handbook	E2083-90000
BNC cable	8120-1839		
BNC-N adapter	1250-0780		

1 Option 0BW only

2 The power cable depends on where the instrument is used, see figure 10-14.

3 Option 1D5 only

4 Option 1D7 only

5 Option 1CN only

6 Option 1CM only

7 Option 1CP only

System Performance

Typical System Performance

Introduction

The performance of the HP 4396B Network/Spectrum Analyzer (analyzer) depends not only on the performance of the analyzer but also on the configuration, the user-selected operating conditions, and the measurement calibration.

This section explains the residual errors remaining in a measurement system after accuracy enhancement. It provides information to calculate the total measurement uncertainty of different configurations. Graphs at the beginning of the section show examples of the performance that can be calculated using the methods in this section.

The sources of measurement errors are explained, with an error model flowgraph and uncertainty equations. Information is provided for conversion of the dynamic accuracy error (in dB) to a linear value for use in the uncertainty equations. The effects of temperature drift on measurement uncertainty are illustrated with graphs.

Typical system performance tables are provided for an 7 mm and 3.5mm systems using an HP 85046A test set, for 50 Ω type-N systems using the HP 85046A and HP 87512A test sets, and 75 Ω type-N systems using the HP 85046B and HP 87512B test sets.

Procedure and blank worksheets are supplied to compute the total error-corrected measurement uncertainty of a system. These procedures combine the terms in the tables, the uncertainty equation, and the nominal S-parameter data of the device under test.

Comparison of Typical Error-Corrected Measurement Uncertainty

Figure 11-1 through Figure 11-8 are examples of the measurement uncertainty data that can be calculated using the information provided in this section. These figures compare the reflection and transmission measurement uncertainty of a 7 mm system using different levels of error correction. Each figure shows uncorrected values and residual uncertainty values after response calibration, response and isolation calibration, and full one or two port calibration. The data applies to a frequency range of 300 kHz to 1.8 GHz with a stable temperature (no temperature drift), using compatible 7 mm calibration devices from the HP 85031B calibration kit.

The results shown in Figure 11-1 through Figure 11-8 can be obtained using the HP 85046A. Different measurement calibration procedures provide comparable measurement improvement for the following compatible connector types and test sets (using the compatible calibration kits):

- 3.5 mm connectors
- HP 85046A and 87512A with 50 Ω type-N connectors
- HP 85046B and 87512B with 75 Ω type-N connectors

Reflection Uncertainty of a One-Port Device

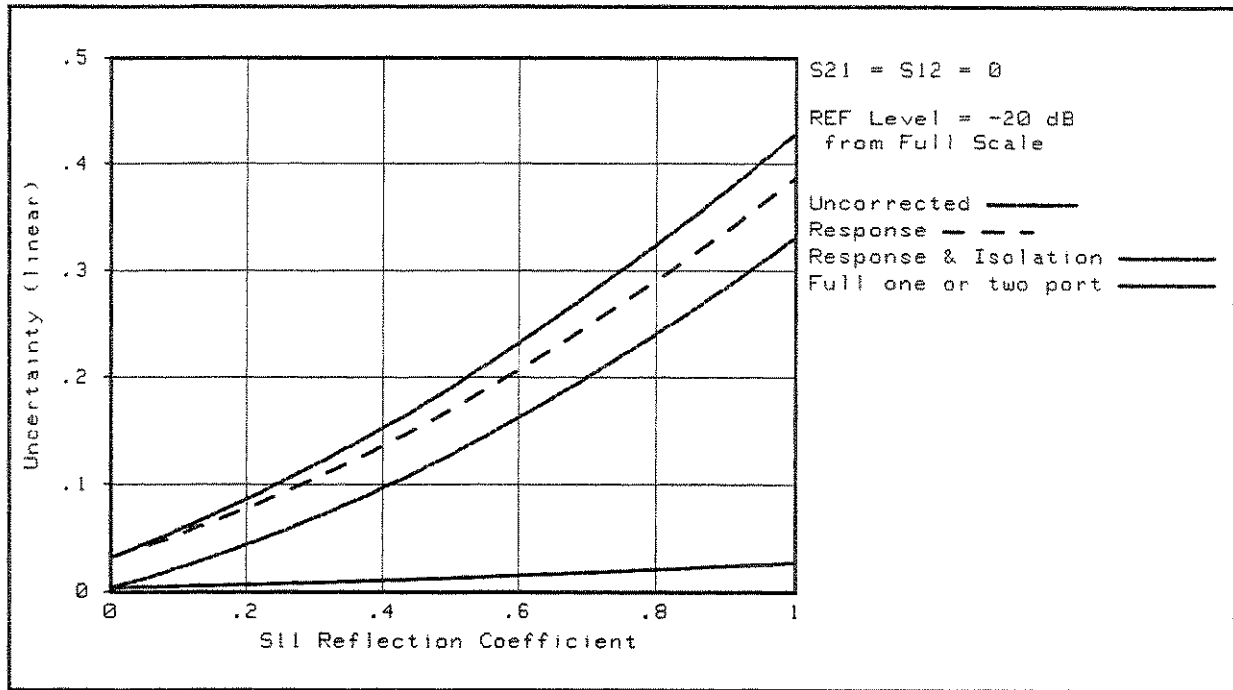

Figure 11-1. Total Reflection Magnitude Uncertainty of One-Port Device

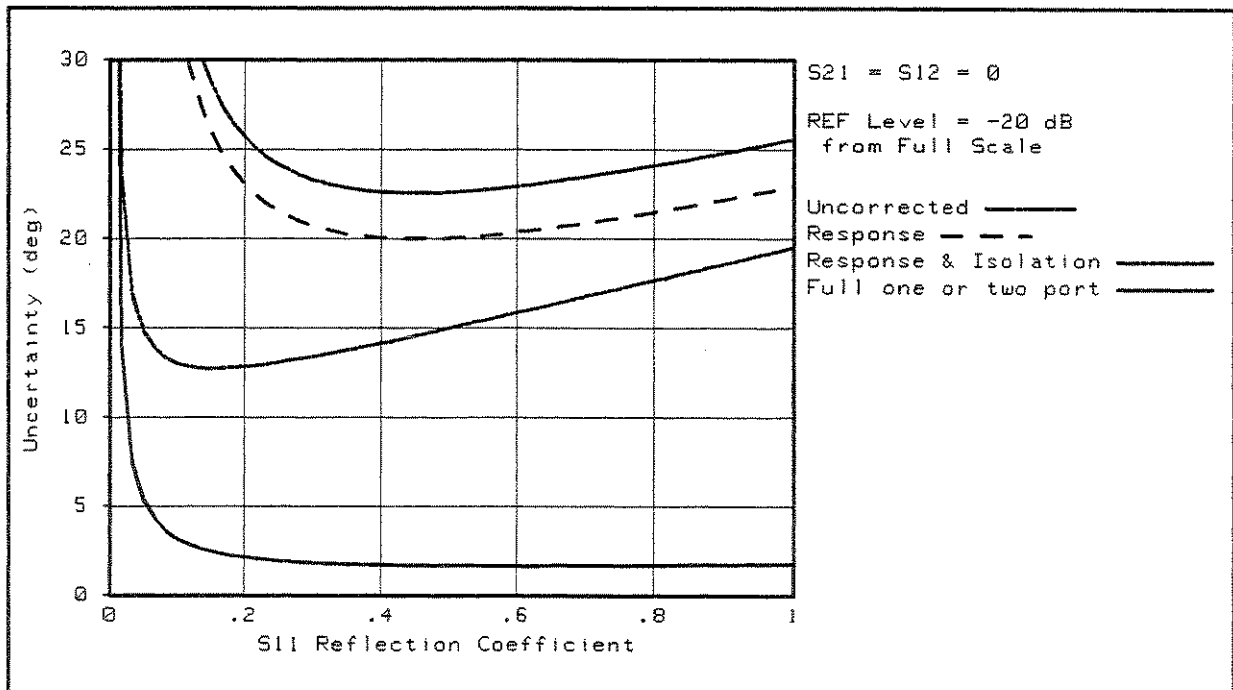

Figure 11-2. Total Reflection Phase Uncertainty of One-Port Device

Transmission Uncertainty of a Low-Loss Device

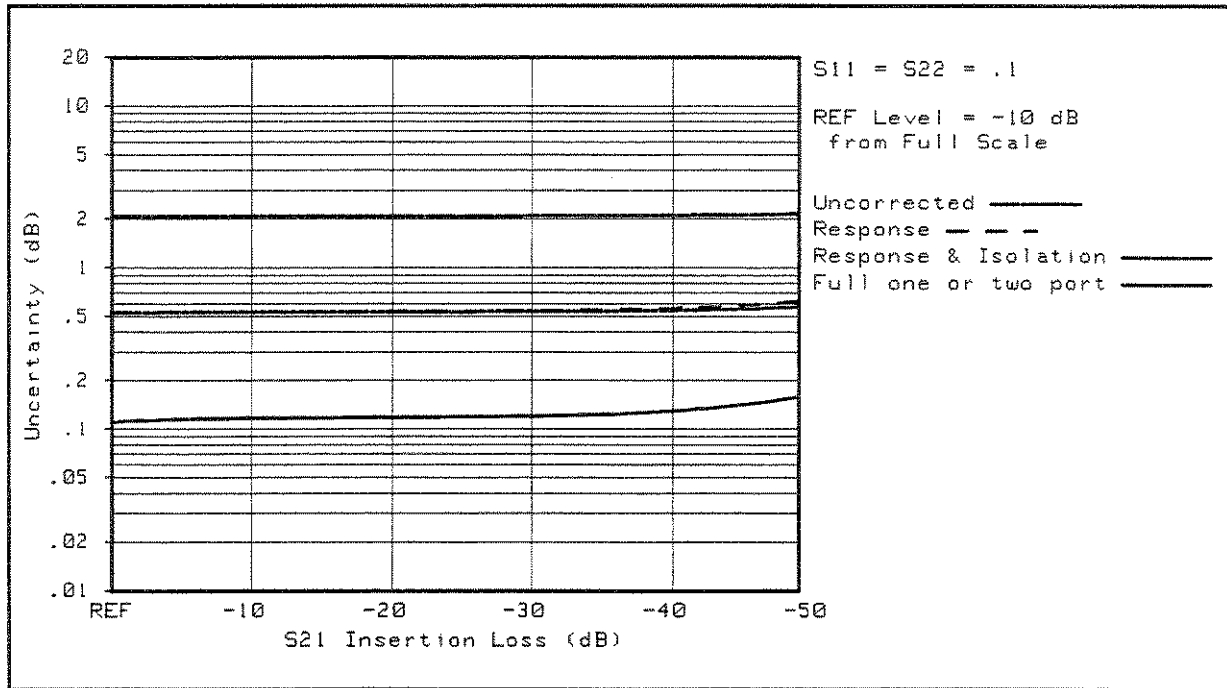

Figure 11-5. Total Transmission Magnitude Uncertainty of a Low-Loss Device

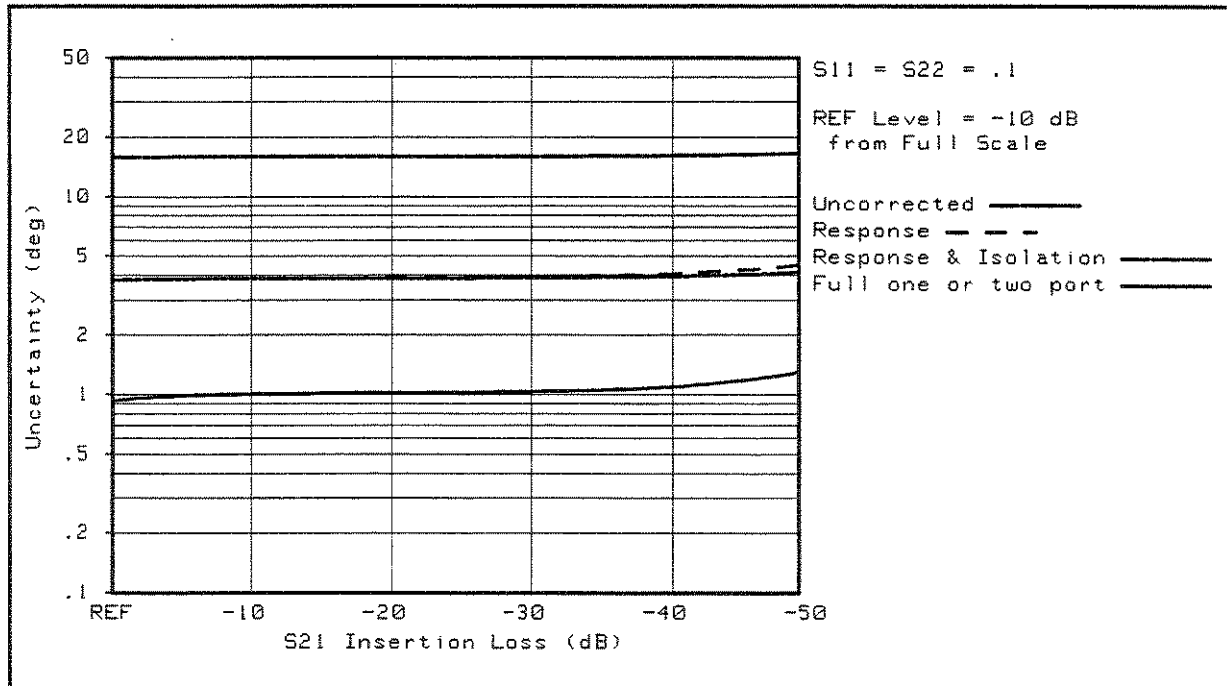

Figure 11-6. Total Transmission Phase Uncertainty of a Low-Loss Device

Transmission Uncertainty of a Wide Dynamic Range Device

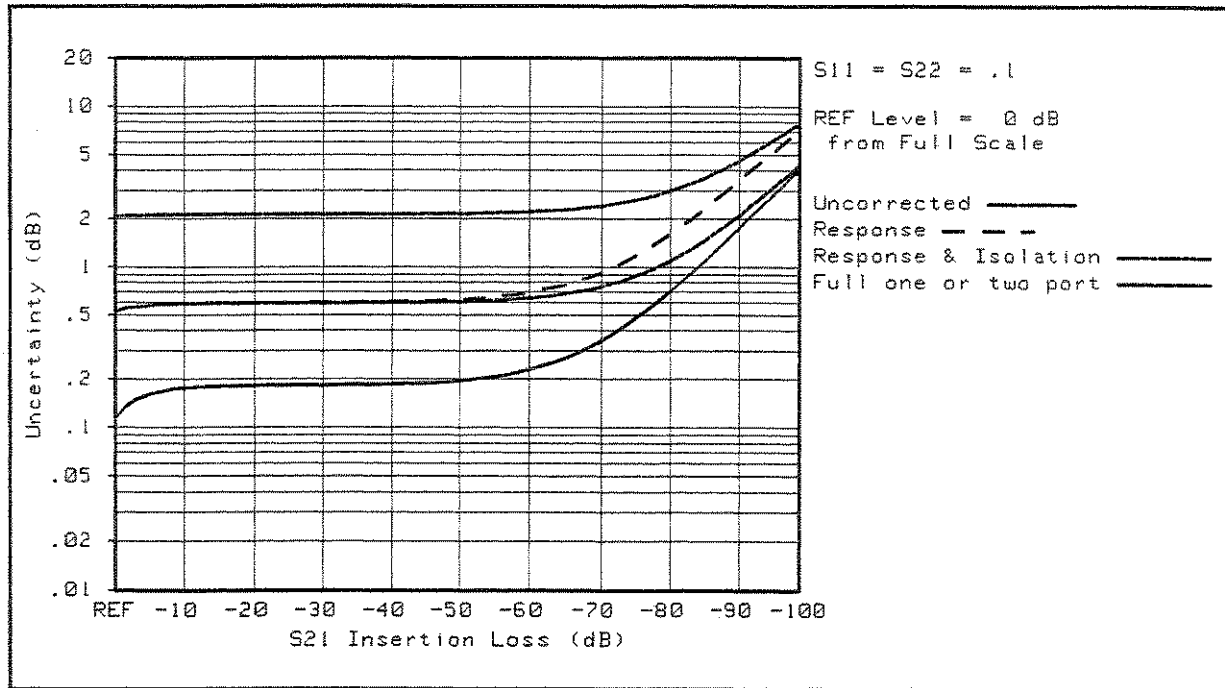

Figure 11-7. Total Transmission Magnitude Uncertainty of a Wide Dynamic Range Device

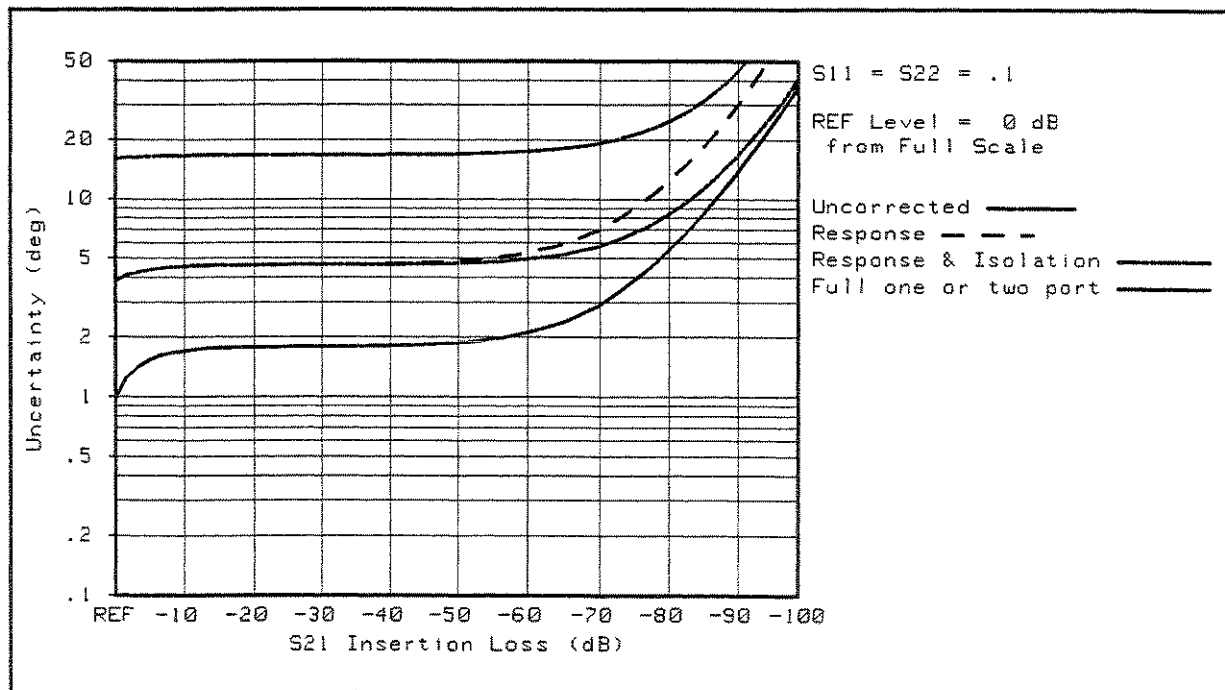

Figure 11-8. Total Transmission Phase Uncertainty of a Wide Dynamic Range Device

Reflection Uncertainty of a Two-Port Device

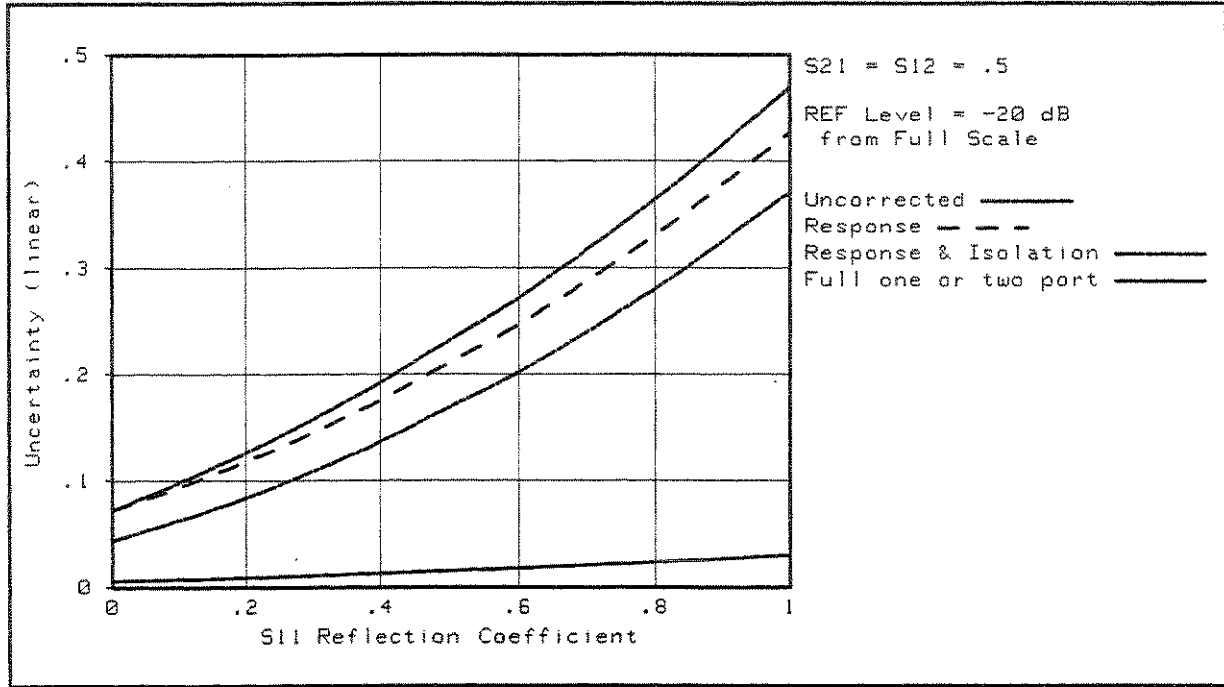

Figure 11-3. Total Reflections Magnitude Uncertainty of Two-Port Device

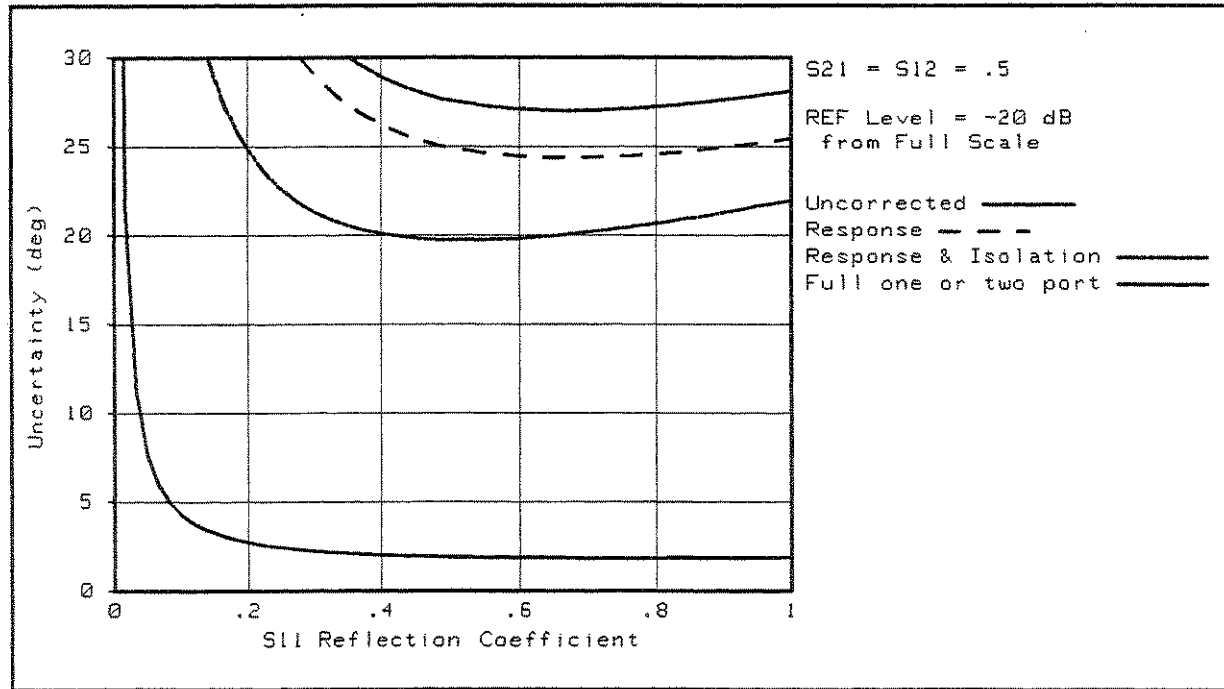

Figure 11-4. Total Reflection Phase Uncertainty of Two-Port Device

Types of Residual Measurement Errors

Network analysis measurement errors can be separated into three types: systematic, random, and drift errors. Measurement errors that remain after measurement calibration are called residual measurement errors. See "Calibration for Network Measurement" in Chapter 12 for a detailed description of the systematic errors corrected by measurement calibration.

Residual Systematic Errors

These errors result from imperfections in the calibration standards, connector standards and interface, interconnecting cables, and instrumentation. These are the errors that affect transmission and reflection measurements.

Transmission Measurements	Reflection Measurements
Dynamic accuracy	
Effective switch port match	
Effective load match	
Effective source match	
Switch tracking	
Multiplexer switching Uncertainty	
Frequency error	
Effective crosstalk	Effective directivity
Effective transmission tracking	Effective reflection tracking
Cable stability	

Residual Random Errors

These non-repeatable errors are due to trace noise, noise floor, and connector repeatability. They affect both transmission and reflection measurements.

Residual Drift Errors

These errors stem from frequency drift and instrumentation drift. They affect both kinds of measurements. Instrumentation drift is primarily temperature related.

System Error Model

Any measurement result is the vector sum of the actual test device response plus all error terms. The precise effect of each error term depends upon its magnitude and phase relationship to the actual test device response. When the phase of an error response is not known, phase is assumed to be worst case (0 or 180 degrees). Random errors such as noise and connector repeatability are generally combined in a root-sum-of-the-squares (RSS) manner. The error term related to thermal drift is combined on a typical basis as shown in each uncertainty equation given in the following paragraphs.

Figure 11-9 shows the error model for the analyzer with the HP 85046A/B S-parameter test set. This error model shows the relationship of the various error sources in the forward direction and can be used to analyze overall measurement performance. The model for signal flow in the reverse direction is similar. Note the appearance of the dynamic accuracy, noise errors, switch errors, and connector repeatability terms in both the reflection and transmission portions of the model.

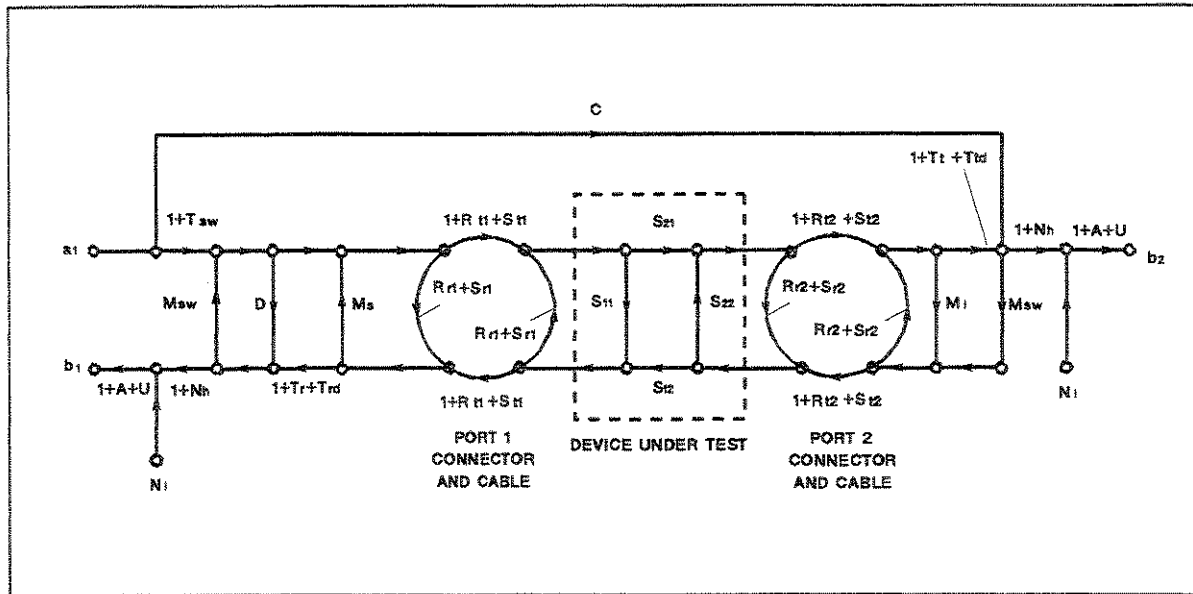

25011009

Figure 11-9. HP 4396B/85046A System Error Model

Table 11-1. Parameters of System error Model

A	= Dynamic Accuracy (A_m = Magnitude Dynamic Accuracy) (A_p = Phase Dynamic Accuracy)	U	= Multiplexer Switching Uncertainty (U_m = Magnitude Multiplexer Switching Uncertainty) (U_p = Phase Multiplexer Switching Uncertainty)
N_1	= Noise Floor	M_s	= Residual Source Match
N_h	= High Level Noise	M_1	= Residual Load Match
T_{sw}	= Switch Tracking	C	= Residual Crosstalk
M_{sw}	= Switch Port Match	T_r	= Residual Reflection Tracking
R_{r1}	= Port 1 Reflection Repeatability	T_t	= Residual Transmission Tracking
R_{r2}	= Port 2 Reflection Repeatability	S_{r1}	= Port 1 Cable Reflection Stability
R_{t1}	= Port 1 Transmission Repeatability	S_{r2}	= Port 2 Cable Reflection Stability
R_{t2}	= Port 2 Transmission Repeatability	S_{t1}	= Port 1 Cable Transmission Stability
T_{rd}	= Reflection Tracking Drift	S_{t2}	= Port 2 Cable Transmission Stability
T_{td}	= Transmission Tracking Drift	D	= Residual Directivity

For measurement of one-port devices, set the crosstalk (C), load match (M_1), transmission tracking (T_t), transmission tracking drift (T_{td}), port 2 connector repeatability (R_{r2} , R_{t2}), and port 2 cable stability (S_{r2} , S_{t2}) error terms to zero.

Reflection Uncertainty Equations

Total Reflection Magnitude Uncertainty (E_{rm})

An analysis of the error model yields an equation for the reflection magnitude uncertainty. The equation contains all of the first order terms and the significant second order terms. The error term related to thermal drift is combined on a worst case basis with the total of systematic and random errors. The four terms under the radical are random in character and are combined on an RSS basis. The terms in the systematic error group are combined on a worst case basis. In all cases, the error terms and the S-parameters are treated as linear absolute magnitudes.

$$E_{rm(\text{linear})} = V_r + S_{11} T_{rd(\text{magnitude})}$$

and

$$E_{rm(\text{log})} = 20 \log \left(1 \pm \frac{E_{rm}}{S_{11}} \right)$$

where

$$V_r = S_r + \sqrt{W_r^2 + X_r^2 + Y_r^2 + Z_r^2}$$

S_r = systematic error

$$= (1 + T_{sw})(D + S_{r1}) + (T_{sw} + T_r)S_{11} + (M_{sw} + M_s + S_{r1})S_{11}^2 \\ + (M_l + S_{r2} + M_{sw})S_{21}S_{12} + (A_m + U_m)S_{11}$$

W_r = random low-level noise

$$= 3N_l$$

X_r = random high-level noise

$$= 3N_h S_{11}$$

Y_r = random port1 repeatability

$$= R_{r1} + 2R_{t1}S_{11} + R_{r1}S_{11}^2$$

Z_r = random port2 repeatability

$$= R_{r2}S_{21}S_{12}$$

Total Reflection Phase Uncertainty (E_{rp})

Reflection phase uncertainty is determined from a comparison of the magnitude uncertainty with the test signal magnitude. The worst case phase angle is computed. This result is combined with the error terms related to thermal drift of the total system, port 1 cable stability, phase dynamic accuracy, and phase multiplexer switching uncertainty.

$$E_{rp} = \arcsin \left(\frac{V_r - (A_m + U_m)S_{11}}{S_{11}} \right) + T_{rd(\text{phase})} + 2S_{t1} + A_p + U_p$$

Transmission Uncertainty Equations

Total Transmission Magnitude Uncertainty (E_{tm})

An analysis of the error model in Figure 11-9 yields an equation for the transmission magnitude uncertainty. The equation contains all of the first order terms and some of the significant second order terms. The error term related to thermal drift is combined on a worst case basis with the total of systematic and random errors. The four terms under the radical are random in character and are combined on an RSS basis. The terms in the systematic error group are combined on a worst case basis. In all cases, the error terms are treated as linear absolute magnitudes.

$$E_{tm(\text{linear})} = V_t + S_{21} T_{td(\text{magnitude})}$$

and

$$E_{tm(\text{log})} = 20 \log \left(1 \pm \frac{E_{tm}}{S_{21}} \right)$$

where

$$V_t = S_t + \sqrt{W_t^2 + X_t^2 + Y_t^2 + Z_t^2}$$

S_t = systematic error

$$= C + (T_{sw} + T_t)S_{21} + (M_{sw} + M_s + S_{r1})S_{11}S_{21} + (M_{sw} + M_l + S_{r2})S_{21}S_{22} + (A_m + U_m)S_{21}$$

W_t = random low-level noise

$$= 3N_l$$

X_t = random high-level noise

$$= 3N_h S_{21}$$

Y_t = random port1 repeatability

$$= R_{t1}S_{21} + R_{r1}S_{11}S_{21}$$

Z_t = random port2 repeatability

$$= R_{t2}S_{21} + R_{r2}S_{22}S_{21}$$

Total Transmission Phase Uncertainty (E_{tp})

Transmission phase uncertainty is calculated from a comparison of the magnitude uncertainty with the test signal magnitude. The worst case phase angle is computed. This result is combined with the error terms related to phase dynamic accuracy, cable phase stability, thermal drift of the total system, and phase multiplexer switching uncertainty.

$$E_{tp} = \arcsin \left(\frac{V_t - (A_m + U_m)S_{21}}{S_{21}} \right) + T_{td(\text{phase})} + S_{t1} + S_{t2} + A_p + U_p$$

Dynamic Accuracy

The dynamic accuracy value used in the system uncertainty equations is obtained from the analyzer's dynamic accuracy typical values. The typical value for magnitude dynamic accuracy is in dB, and it must be converted to a linear value to be used in the uncertainty equations. In addition, the analyzer's dynamic accuracy typical values are given for an input signal level from full scale in dB. This must be converted to a relative error (relative to the power at which the measurement calibration occurs) to be used in the system uncertainty equations.

$$\text{Dynamic Accuracy (linear)} = 10^{\frac{\pm \text{DynAcc(dB)}}{20}} \mp 1$$

$$\text{Dynamic Accuracy (dB)} = 20 \log(1 \pm \text{Dynamic Accuracy (linear)})$$

Magnitude Dynamic Accuracy

Typical magnitude dynamic accuracy can be expressed the following equations:

$$\text{Magnitude Dynamic Accuracy} = E_{d1m} + E_{d2m} + E_{d3m}$$

$$E_{d1m} = 8.09 \times 10^{-3} L^2$$

$$E_{d2m} = 1.73 \times 10^{-3} L^{0.221} + 1.15 \times 10^{-3}$$

$$E_{d3m} = \frac{2.92 \times 10^{-7}}{L}$$

where,

L = Measurement level (linear, relative to full scale level)

E_{d1m} = Magnitude compression error (dominant at high measurement level range)

E_{d2m} = Magnitude residual error (dominant at middle measurement level range)

E_{d3m} = Magnitude A/D converter differential nonlinearity error (dominant at low measurement level range)

Determining Relative Magnitude Dynamic Accuracy Error Contribution

Typical magnitude dynamic accuracy error contribution to system performance is expressed below:

$$\begin{aligned} \text{Magnitude dynamic accuracy error} = & |E_{d1m\text{MEAS}} - E_{d1m\text{REF}}| \\ & + \max(E_{d2m\text{MEAS}}, E_{d2m\text{REF}}) \\ & + E_{d3m\text{MEAS}} + E_{d3m\text{REF}} \end{aligned}$$

where,

Suffix REF means errors at calibration

Suffix MEAS means errors at DUT measurement

Phase Dynamic Accuracy

Typical phase dynamic accuracy can be expressed by the following equations:

$$\text{Magnitude Dynamic Accuracy} = E_{d1p} + E_{d2p} + E_{d3p}$$

$$E_{d1p} = 0.8L^2$$

$$E_{d2p} = 0.15L^{0.383} + 0.06$$

$$E_{d3p} = \frac{2.5 \times 10^{-5}}{L}$$

where,

L = Measurement level (linear, relative to full scale level)

E_{d1p} = Phase compression error (dominant at high measurement level range)

E_{d2p} = Phase residual error (dominant at middle measurement level range)

E_{d3p} = Phase A/D converter differential nonlinearity error (dominant at low measurement level range)

Determining Relative Phase Dynamic Accuracy Error Contribution

Typical dynamic accuracy error contribution to system performance is expressed below:

$$\begin{aligned} \text{Phase dynamic accuracy error} = & |E_{d1p\text{MEAS}} - E_{d1p\text{REF}}| \\ & + \max(E_{d2p\text{MEAS}}, E_{d2p\text{REF}}) \\ & + E_{d3p\text{MEAS}} + E_{d3p\text{REF}} \end{aligned}$$

where,

Suffix REF means errors at calibration

Suffix MEAS means errors at DUT measurement

Six example graphs are provided: Figure 11-10 and Figure 11-11 show the typical magnitude and phase dynamic accuracy error with a reference power level of full scale, Figure 11-12 and Figure 11-13 with a reference power level of -20 dB from full scale, and Figure 11-14 and Figure 11-15 with a reference power level of -60 dB from full scale.

Dynamic Accuracy Error Contribution

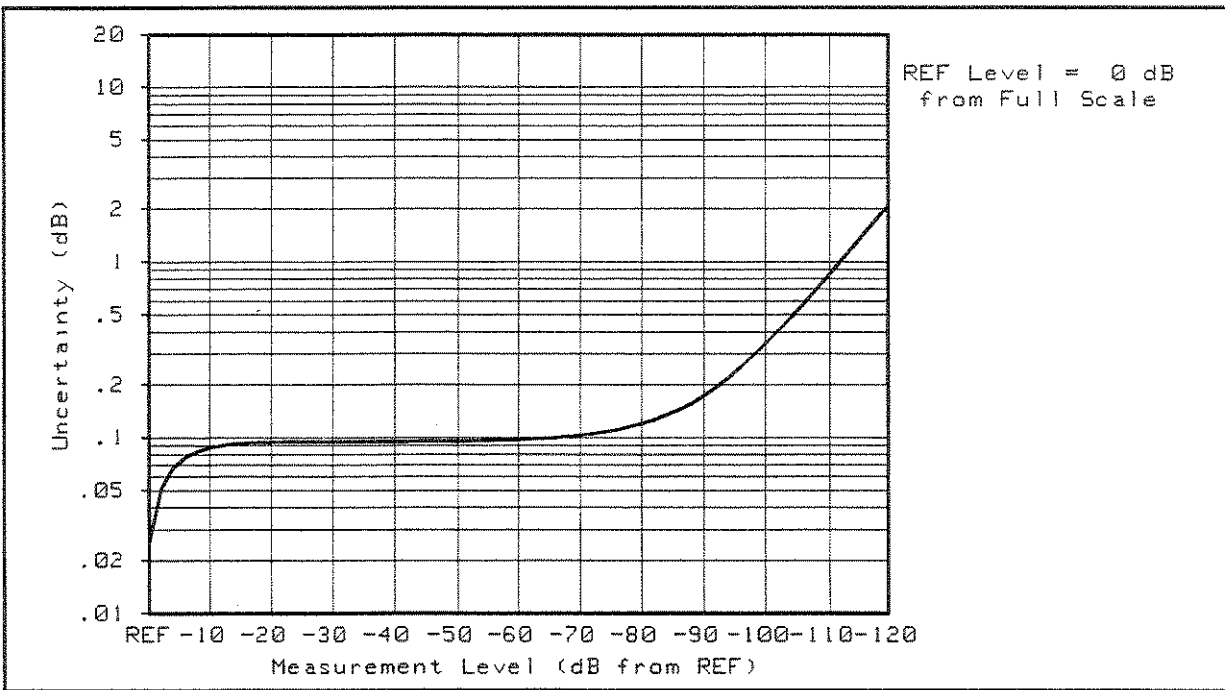

Figure 11-10.
Typical Magnitude Dynamic Accuracy Error
(@Reference Power Level = Full Scale)

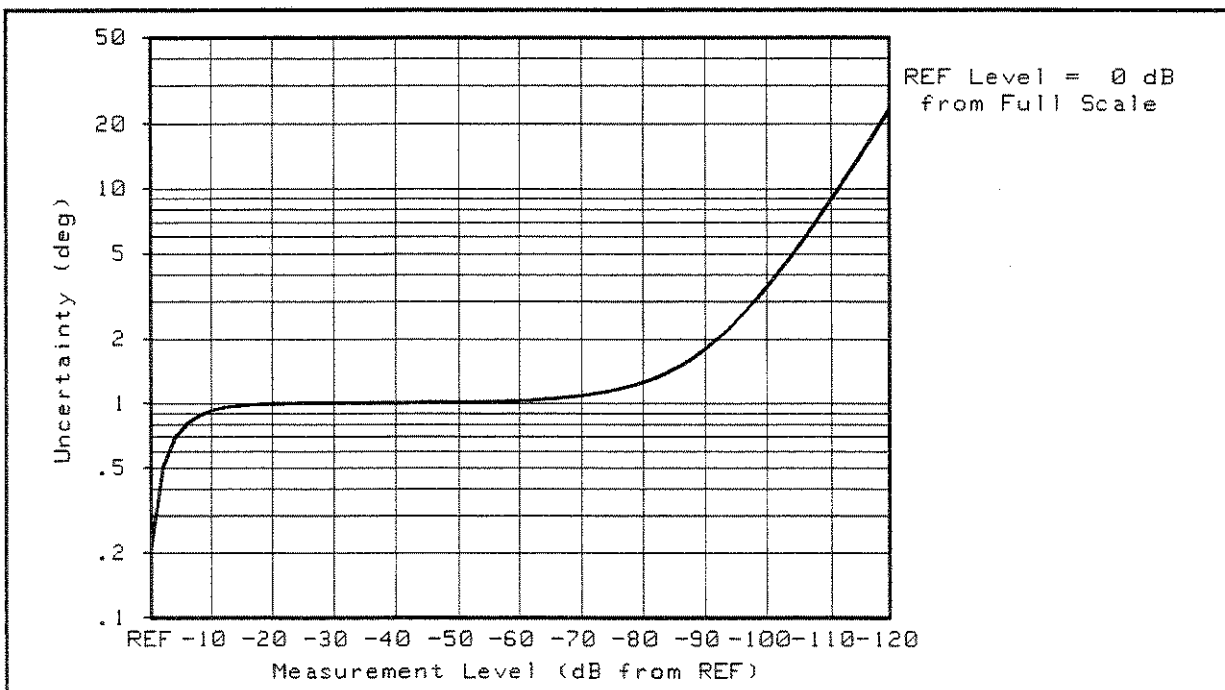

Figure 11-11.
Typical Phase Dynamic Accuracy Error
(@Reference Power Level = Full Scale)

Dynamic Accuracy Error Contribution

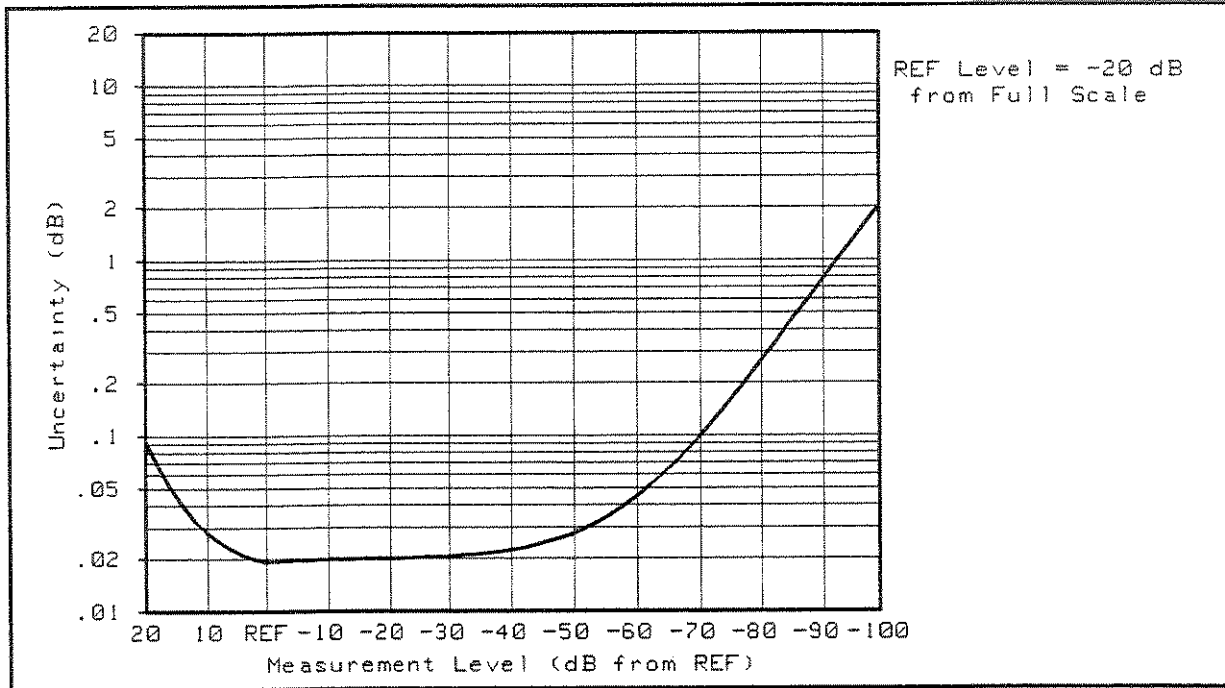

Figure 11-12.
Typical Magnitude Dynamic Accuracy Error
 (@Reference Power Level = -20 dB from Full Scale)

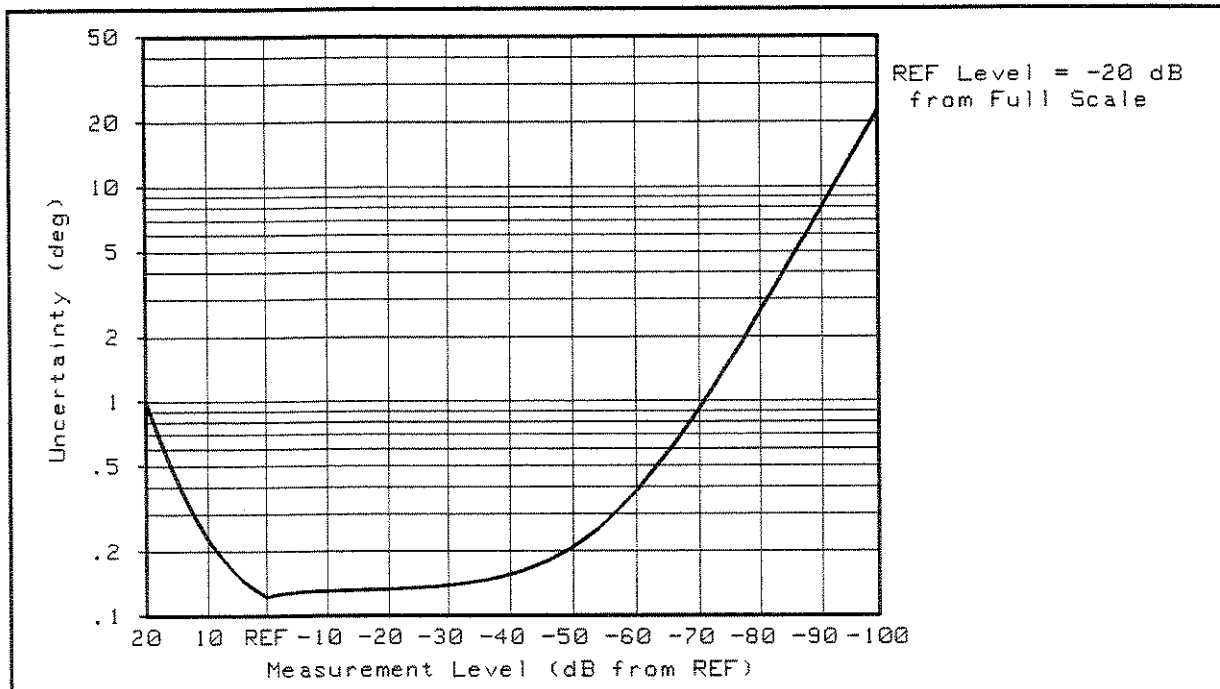

Figure 11-13.
Typical Phase Dynamic Accuracy Error
 (@Reference Power Level = -20 dB from Full Scale)

Dynamic Accuracy Error Contribution

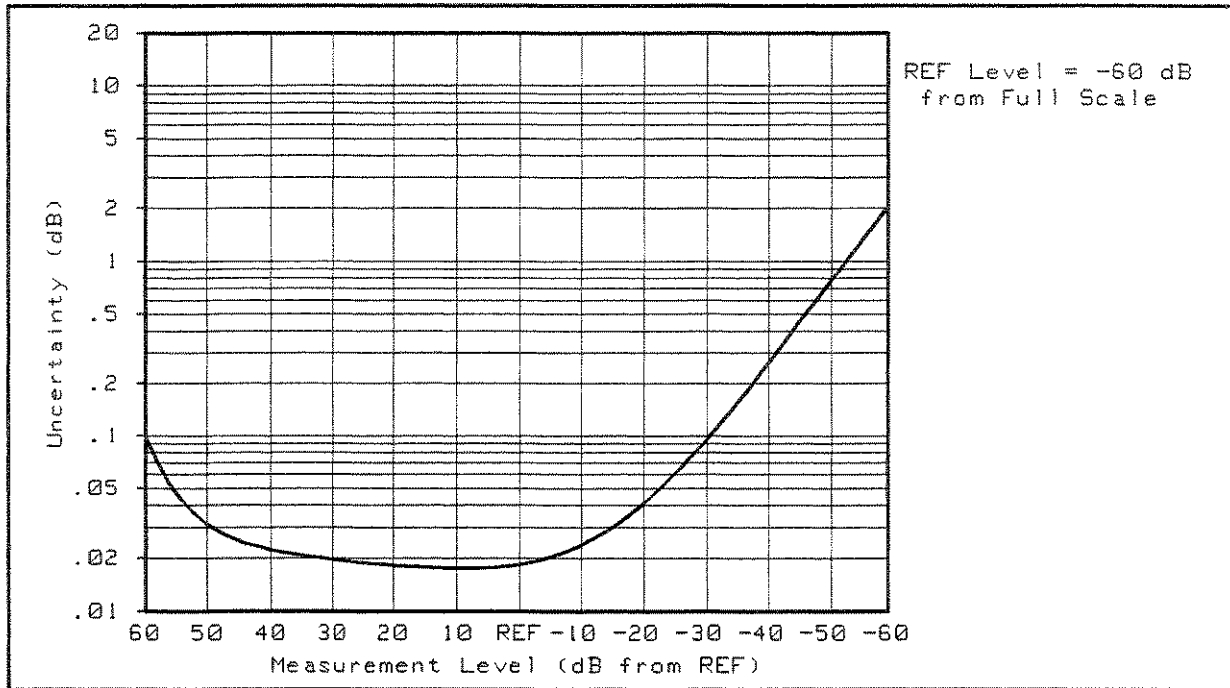

Figure 11-14.
Typical Magnitude Dynamic Accuracy Error
(@Reference Power Level = -60 dB from Full Scale)

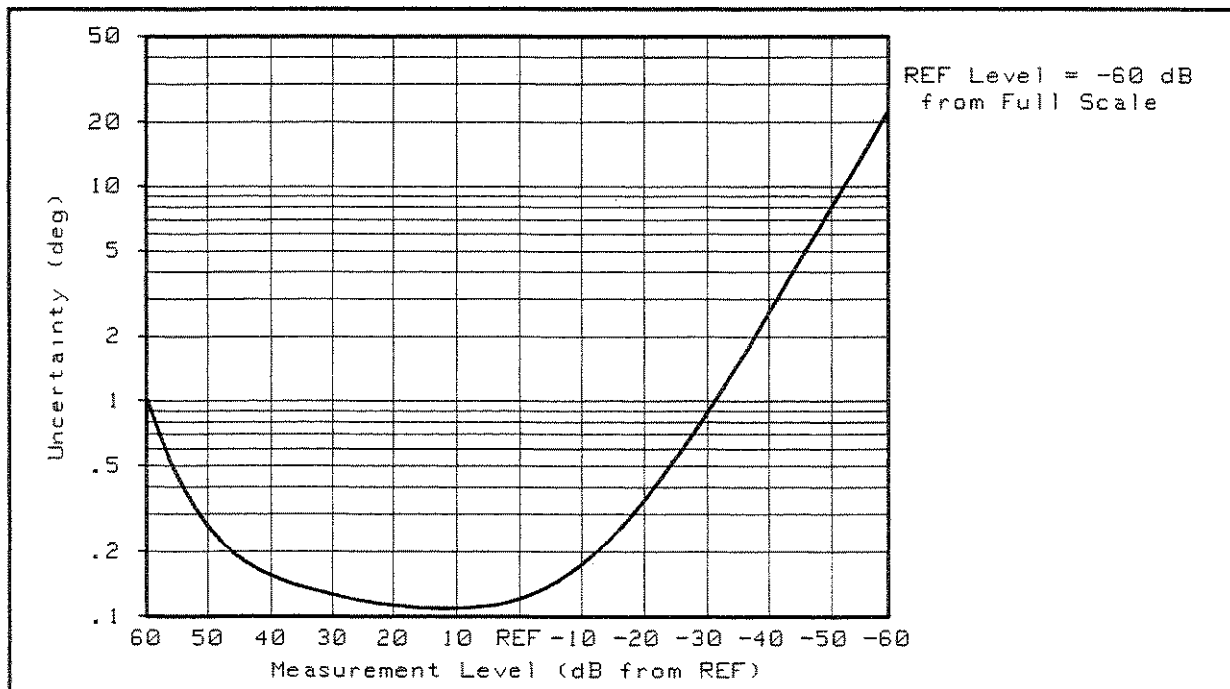

Figure 11-15.
Typical Phase Dynamic Accuracy Error
(@Reference Power Level = -60 dB from Full Scale)

Effects of Temperature Drift

Figure 11-16 to Figure 11-19 are graphs showing the effects of temperature drift on error-corrected measurement uncertainty values. Values are shown for changes of $\pm 1^\circ\text{C}$, $\pm 3^\circ\text{C}$ and $\pm 5^\circ\text{C}$ from the ambient temperature. Figure 11-16 and Figure 11-17 show total reflection magnitude and phase uncertainty with temperature drift following an S_{11} one-port calibration. Figure 11-18 and Figure 11-19 show total transmission magnitude and phase uncertainty with temperature drift following a full two-port error correction. The graphs apply to measurements up to 1.8 GHz.

Temperature Drift with S_{11} One-Port Calibration

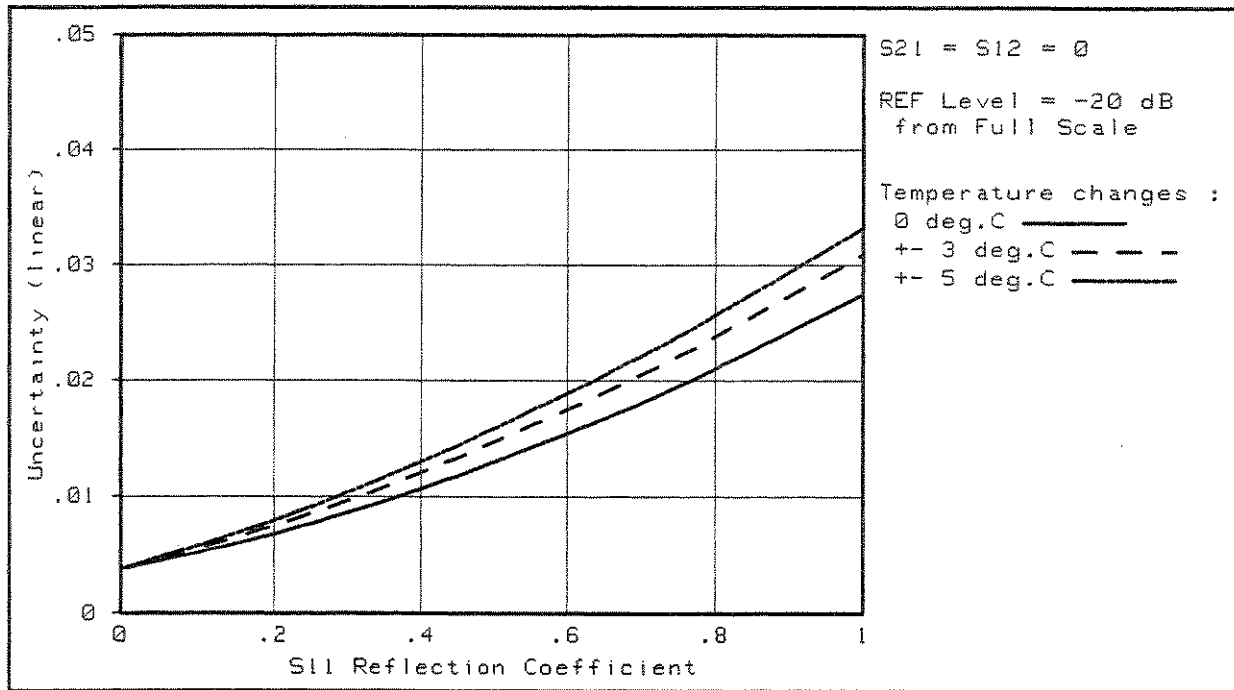

Figure 11-16. Total Reflection Magnitude Uncertainty (@One-Port Cal)

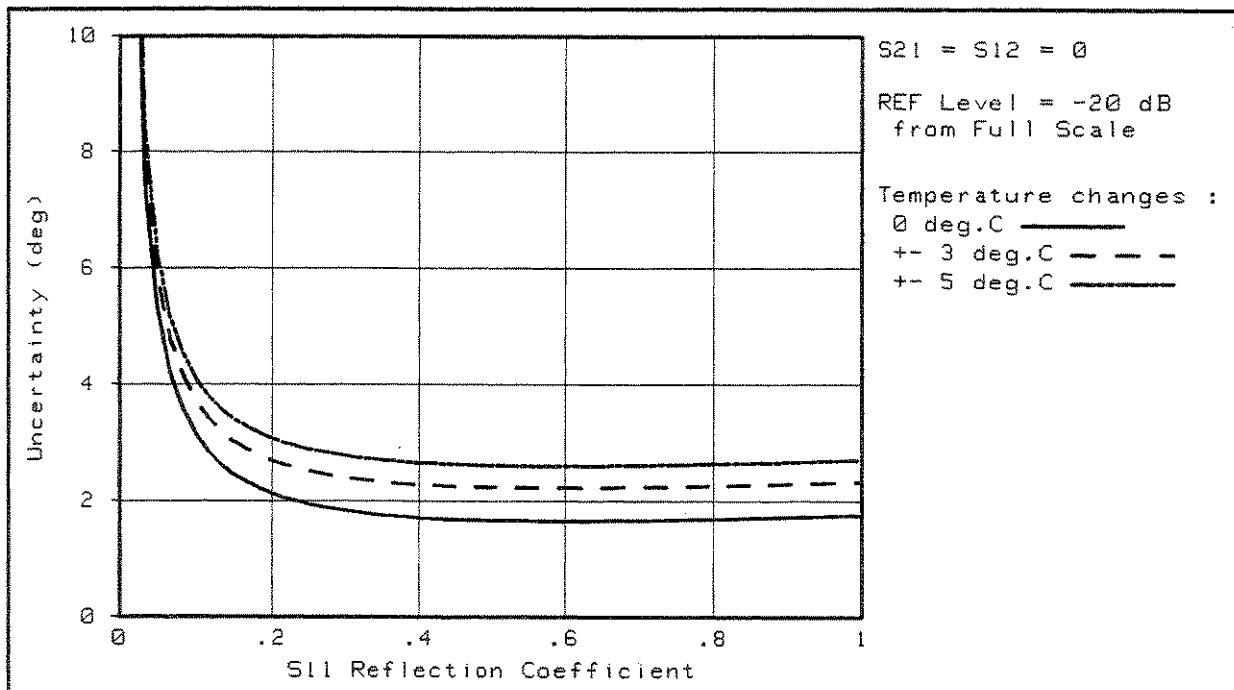

Figure 11-17. Total Reflection Phase Uncertainty (@One-Port Cal)

Temperature Drift with Full Two-Port Calibration

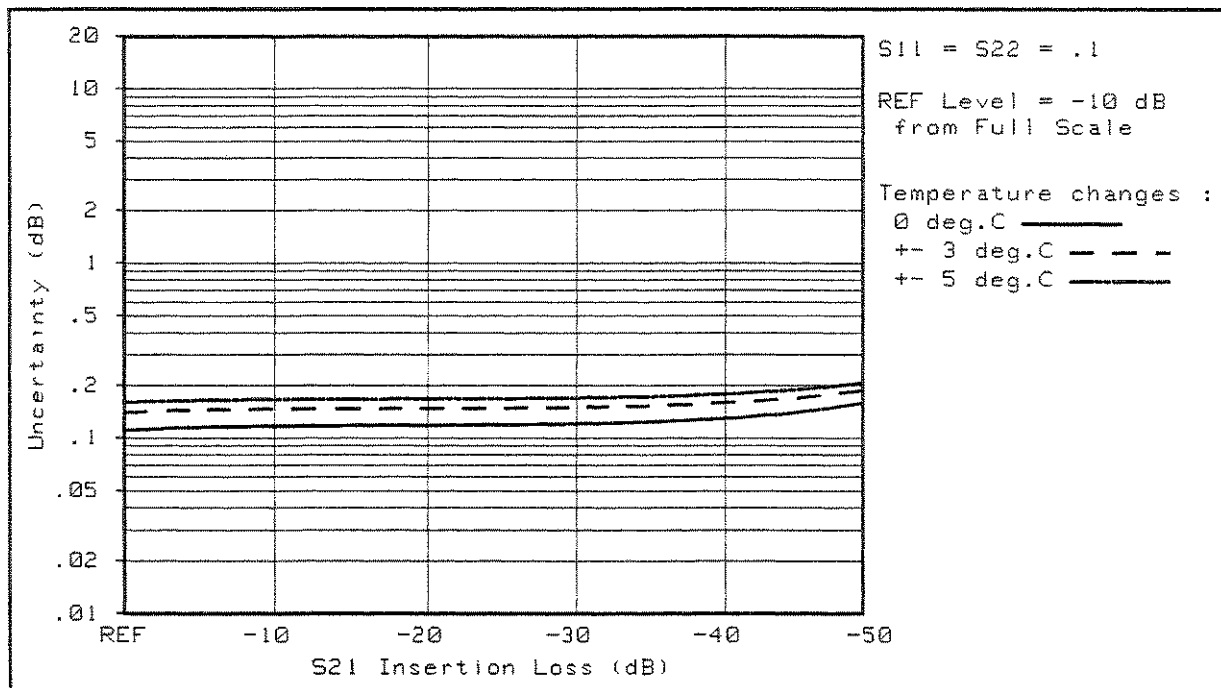

Figure 11-18. Total Transmission Magnitude Uncertainty (@Full Two-Port Cal)

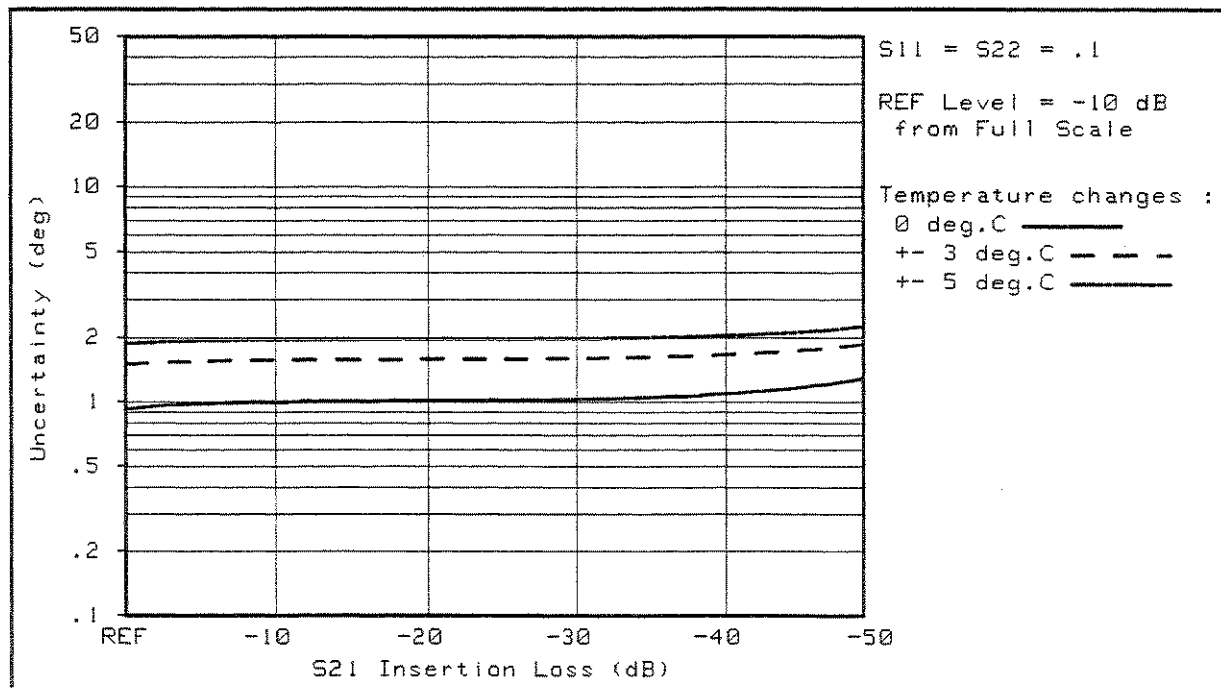

Figure 11-19. Total Transmission Phase Uncertainty (@Full Two-Port Cal)

System performance with Different Test Sets and Connector Types

The tables in the following pages provides typical system performance for sytems using different test sets and different connector types. The values listed are for uncorrected measurements and for corrected measurements after measurement calibration. The linear value is shown in parenthesis with the dB value.

Table 11-2.
Typical System Performance for Devices with 7 mm Connectors
HP 4396B with HP 85046A Test Set (300 kHz to 1.8 GHz)

Symbol	Error Terms	Uncorrected	Typical Residual after Accuracy Enhancement ^{1, 2}			
			Response Only	Response and Isolation	One-Port	Full two port
D	Directivity	-30 dB (3.2×10^{-2})	-30 dB (3.2×10^{-2})	-50 dB ³ (3.2×10^{-3})	-50 dB (3.2×10^{-3})	-50 dB (3.2×10^{-3})
M _s	Source Match	-16 dB (0.16)	-16 dB (0.16)	-16 dB (0.16)	-40 dB (0.01)	-40 dB (0.01)
T _r	Reflection Tracking	±1.8 dB (0.23)	±1.5 dB (0.19)	±1.3 dB (0.16)	±0.05 dB (5.8×10^{-3})	±0.05 dB (5.8×10^{-3})
M _l	Load Match	-16 dB (0.16)	-16 dB (0.16)	-16 dB (0.16)	-	-42 dB (7.9×10^{-3})
T _t	Trans. Tracking	±1.8 dB (0.23)	±0.2 dB (0.023)	±0.2 dB (0.023)	-	±0.03 dB (3.5×10^{-3})
C	Cross Talk	-100 dB (1.0×10^{-5})	-100 dB (1.0×10^{-5})	-110 dB (3.2×10^{-6})	-110 dB (3.2×10^{-6})	-110 dB (3.2×10^{-6})
R _{r1}	Port1 Refl. Connector Repeatability	-70 dB (3.2×10^{-4})				
R _{t1}	Port1 Trans. Connector Repeatability	-70 dB (3.2×10^{-4})				
R _{r2}	Port2 Refl. Connector Repeatability	-70 dB (3.2×10^{-4})				
R _{t2}	Port2 Trans. Connector Repeatability	-70 dB (3.2×10^{-4})				
N _l	Low-Level Noise ²	-110 dB from full scale (3.2×10^{-6})				
N _h	High Level Noise ^{2,4}	Magnitude: 0.003 dB (3.5×10^{-4})				
A _m , A _p	Dynamic Accuracy Error	See "Dynamic Accuracy" in Chapter 10.				
U _m , U _p	Multiplexer Switching Uncertainty	Magnitude: ±0.0025 dB (2.9×10^{-4}) Phase: 0.015 degrees				
S _{t1}	Port1 Cable Trans. Phase Stability ⁵	0.05 × f (GHz) degrees				
S _{r1}	Port1 Cable Refl. Stability ⁵	-70 dB (3.2×10^{-4})				
S _{t2}	Port2 Cable Trans. Phase Stability ⁵	0.05 × f (GHz) degrees				
S _{r2}	Port2 Cable Refl. Stability ⁵	-70 dB (3.2×10^{-4})				
T _{td}	Trans. Tracking Drift	Magnitude: 0.01 dB/°C (1.1×10^{-3} /°C) Phase: ⁶ ±[0.1 + 0.15×f(GHz)]degrees/°C				
T _{rd}	Refl. Tracking Drift	Magnitude: 0.01 dB/°C (1.1×10^{-3} /°C) Phase: ⁶ ±[0.1 + 0.15×f(GHz)]degrees/°C				
T _{sw}	Switch Tracking	±0.03 dB (3.5×10^{-3})				
M _{sw}	Switch Port Match	-70 dB (3.2×10^{-4})				

1 Accuracy enhancement procedures are performed using HP 85031B 7 mm calibration kit. Environmental temperature is 23°C ±3°C at calibration: ±1°C from calibration temperature must be maintained for valid measurement calibration.

2 With IF bandwidth of 10 Hz.

3 With impedance matched load.

4 High-level noise is the RMS of a continuous measurement of a short circuit or thru.

5 Arrived at by bending HP 11857D cables out perpendicular to front panel and reconnecting. Stability is much better with less flexing.

6 Arrived at using HP 11857D cables and full 2-port calibration. Drift is much better without cables and with 1-port calibration. For this case, drift typically is [0.1 + 0.05 × f (GHz)] × Δ°C, degrees.

Table 11-3.
Typical System Performance for Devices with 3.5 mm Connectors
HP 4396B with HP 85046A Test Set (300 kHz to 1.8 GHz)

Symbol	Error Terms	Uncorrected	Typical Residual after Accuracy Enhancement ^{1, 2}			
			Response Only	Response and Isolation	One-Port	Full two port
D	Directivity	-30 dB (3.2×10^{-2})	-30 dB (3.2×10^{-2})	-40 dB ³ (0.01)	-40 dB (0.01)	-40 dB (0.01)
M _s	Source Match	-16 dB (0.16)	-16 dB (0.16)	-16 dB (0.16)	-36 dB (0.016)	-36 dB (0.016)
T _r	Reflection Tracking	±1.8 dB (0.23)	±1.5 dB (0.19)	±1.3 dB (0.16)	±0.14 dB (0.016)	±0.14 dB (0.016)
M _l	Load Match	-16 dB (0.16)	-16 dB (0.16)	-16 dB (0.16)	-	-38 dB (0.013)
T _t	Trans. Tracking	±1.8 dB (0.23)	±0.2 dB (0.023)	±0.2 dB (0.023)	-	±0.05 dB (5.8×10^{-3})
C	Cross Talk	-100 dB (1.0×10^{-5})	-100 dB (1.0×10^{-5})	-110 dB (3.2×10^{-6})	-110 dB (3.2×10^{-6})	-110 dB (3.2×10^{-6})
R _{r1}	Port1 Refl. Connector Repeatability	-70 dB (3.2×10^{-4})				
R _{t1}	Port1 Trans. Connector Repeatability	-70 dB (3.2×10^{-4})				
R _{r2}	Port2 Refl. Connector Repeatability	-70 dB (3.2×10^{-4})				
R _{t2}	Port2 Trans. Connector Repeatability	-70 dB (3.2×10^{-4})				
N _l	Low-Level Noise ²	-110 dB from full scale (3.2×10^{-6})				
N _h	High Level Noise ^{2,4}	Magnitude: 0.003 dB (3.5×10^{-4})				
A _m , A _p	Dynamic Accuracy Error	See "Dynamic Accuracy" in Chapter 10.				
U _m , U _p	Multiplexer Switching Uncertainty	Magnitude: ±0.0025 dB (2.9×10^{-4}) Phase: 0.015 degrees				
S _{t1}	Port1 Cable Trans. Phase Stability ⁵	0.05 × f (GHz) degrees				
S _{r1}	Port1 Cable Refl. Stability ⁵	-70 dB (3.2×10^{-4})				
S _{t2}	Port2 Cable Trans. Phase Stability ⁵	0.05 × f (GHz) degrees				
S _{r2}	Port2 Cable Refl. Stability ⁵	-70 dB (3.2×10^{-4})				
T _{td}	Trans. Tracking Drift	Magnitude: 0.01 dB/°C (1.1×10^{-3} /°C)		Phase: ⁶ ±[0.1 + 0.15 × f(GHz)]degrees/°C		
T _{rd}	Refl. Tracking Drift	Magnitude: 0.01 dB/°C (1.1×10^{-3} /°C)		Phase: ⁶ ±[0.1 + 0.15 × f(GHz)]degrees/°C		
T _{sw}	Switch Tracking	±0.03 dB (3.5×10^{-3})				
M _{sw}	Switch Port Match	-70 dB (3.2×10^{-4})				

1 Accuracy enhancement procedures are performed using HP 85033C 3.5 mm calibration kit. Environmental temperature is 23°C ±3°C at calibration: ±1°C from calibration temperature must be maintained for valid measurement calibration.

2 With IF bandwidth of 10 Hz.

3 With impedance matched load.

4 High-level noise is the RMS of a continuous measurement of a short circuit or thru.

5 Arrived at by bending HP 11857D cables out perpendicular to front panel and reconnecting. Stability is much better with less flexing.

6 Arrived at using HP 11857D cables and full 2-port calibration. Drift is much better without cables and with 1-port calibration. For this case, drift typically is [0.1 + 0.05 × f (GHz)] × Δ°C, degrees.

Table 11-4.
Typical System Performance for Devices with 50 Ω Type-N Connectors
HP 4396B with HP 85046A or 85044A Test Set (300 kHz to 1.8 GHz)

Symbol	Error Terms	Uncorrected	Typical Residual after Accuracy Enhancement ^{1, 2}			
			Response Only	Response and Isolation	One-Port	Full two port
D	Directivity	-30 dB (3.2×10^{-2})	-30 dB (3.2×10^{-2})	-44 dB ³ (6.3×10^{-3})	-44 dB (6.3×10^{-3})	-44 dB (6.3×10^{-3})
M _s	Source Match	-16 dB (0.16)	-16 dB (0.16)	-16 dB (0.16)	-35 dB (0.018)	-35 dB (0.018)
T _r	Reflection Tracking	± 1.8 dB (0.23)	± 1.5 dB (0.19)	± 1.4 dB (0.18)	± 0.06 dB (6.9×10^{-3})	± 0.06 dB (6.9×10^{-3})
M _l	Load Match	-16 dB (0.16)	-16 dB (0.16)	-16 dB (0.16)	-	-42 dB (7.9×10^{-3})
T _t	Trans. Tracking	± 1.8 dB (0.23)	± 0.2 dB (0.023)	± 0.2 dB (0.023)	-	± 0.05 dB (5.8×10^{-3})
C	Cross Talk	-100 dB (1.0×10^{-5})	-100 dB (1.0×10^{-5})	-110 dB (3.2×10^{-6})	-110 dB (3.2×10^{-6})	-110 dB (3.2×10^{-6})
R _{r1}	Port1 Refl. Connector Repeatability	-65 dB (5.6×10^{-4})				
R _{t1}	Port1 Trans. Connector Repeatability	-65 dB (5.6×10^{-4})				
R _{r2}	Port2 Refl. Connector Repeatability	-65 dB (5.6×10^{-4})				
R _{t2}	Port2 Trans. Connector Repeatability	-65 dB (5.6×10^{-4})				
N _l	Low-Level Noise ²	-110 dB from full scale (3.2×10^{-6})				
N _h	High Level Noise ^{2,4}	Magnitude: 0.003 dB (3.5×10^{-4})				
A _m , A _p	Dynamic Accuracy Error	See "Dynamic Accuracy" in Chapter 10.				
U _m , U _p	Multiplexer Switching Uncertainty	Magnitude: ± 0.0025 dB (2.9×10^{-4}) Phase: 0.015 degrees				
S _{t1}	Port1 Cable Trans. Phase Stability ⁵	0.05 \times f (GHz) degrees				
S _{r1}	Port1 Cable Refl. Stability ⁵	-70 dB (3.2×10^{-4})				
S _{t2}	Port2 Cable Trans. Phase Stability ⁵	0.05 \times f (GHz) degrees				
S _{r2}	Port2 Cable Refl. Stability ⁵	-70 dB (3.2×10^{-4})				
T _{td}	Trans. Tracking Drift	Magnitude: 0.01 dB/ $^{\circ}$ C (1.1×10^{-3} / $^{\circ}$ C) Phase: ⁶ $\pm [0.1 + 0.15 \times f(\text{GHz})]$ degrees/ $^{\circ}$ C				
T _{rd}	Refl. Tracking Drift	Magnitude: 0.01 dB/ $^{\circ}$ C (1.1×10^{-3} / $^{\circ}$ C) Phase: ⁶ $\pm [0.1 + 0.15 \times f(\text{GHz})]$ degrees/ $^{\circ}$ C				
T _{sw}	Switch Tracking	± 0.03 dB (3.5×10^{-3})				
M _{sw}	Switch Port Match	-70 dB (3.2×10^{-4})				

1 Accuracy enhancement procedures are performed using HP 85032B 50 Ω type-N calibration kit. Environmental temperature is 23°C \pm 3°C at calibration: $\pm 1^{\circ}$ C from calibration temperature must be maintained for valid measurement calibration.

2 With IF bandwidth of 10 Hz.

3 With impedance matched load.

4 High-level noise is the RMS of a continuous measurement of a short circuit or thru.

5 Arrived at by bending HP 11857D cables out perpendicular to front panel and reconnecting. Stability is much better with less flexing.

6 Arrived at using HP 11857D cables and full 2-port calibration. Drift is much better without calbes and with 1-port calibration. For this case, drift typically is $[0.1 + 0.05 \times f(\text{GHz})] \times \Delta^{\circ}$ C, degrees.

Table 11-5.
Typical System Performance for Devices with 75 Ω Type-N Connectors
HP 4396B with HP 85046B or 85044B Test Set (300 kHz to 1.8 GHz)

Symbol	Error Terms	Uncorrected	Typical Residual after Accuracy Enhancement ^{1, 2}			
			Response Only	Response and Isolation	One-Port	Full two port
D	Directivity	-30 dB (3.2×10^{-2})	-30 dB (3.2×10^{-2})	-44 dB ³ (6.3×10^{-3})	-44 dB (6.3×10^{-3})	-44 dB (6.3×10^{-3})
M _s	Source Match	-16 dB (0.16)	-16 dB (0.16)	-16 dB (0.16)	-35 dB (0.018)	-35 dB (0.018)
T _r	Reflection Tracking	±1.8 dB (0.23)	±1.5 dB (0.19)	±1.4 dB (0.18)	±0.06 dB (6.9×10^{-3})	±0.06 dB (6.9×10^{-3})
M _i	Load Match	-16 dB (0.16)	-16 dB (0.16)	-16 dB (0.16)	-	-42 dB (7.9×10^{-3})
T _i	Trans. Tracking	±1.8 dB (0.23)	±0.2 dB (0.023)	±0.2 dB (0.023)	-	±0.05 dB (5.8×10^{-3})
C	Cross Talk	-94 dB (2.0×10^{-5})	-94 dB (2.0×10^{-5})	-104 dB (6.3×10^{-6})	-104 dB (6.3×10^{-6})	-104 dB (6.3×10^{-6})
R _{r1}	Port1 Refl. Connector Repeatability	-65 dB (5.6×10^{-4})				
R _{t1}	Port1 Trans. Connector Repeatability	-65 dB (5.6×10^{-4})				
R _{r2}	Port2 Refl. Connector Repeatability	-65 dB (5.6×10^{-4})				
R _{t2}	Port2 Trans. Connector Repeatability	-65 dB (5.6×10^{-4})				
N _i	Low-Level Noise ²	-94 dB from full scale (2.0×10^{-5})				
N _h	High Level Noise ^{2,4}	Magnitude: 0.003 dB (3.5×10^{-4})				
A _{m,Ap}	Dynamic Accuracy Error	See "Dynamic Accuracy" in Chapter 10.				
U _{m,U_p}	Multiplexer Switching Uncertainty	Magnitude: ±0.0025 dB (2.9×10^{-4}) Phase: 0.015 degrees				
S _{t1}	Port1 Cable Trans. Phase Stability ⁵	0.05 × f (GHz) degrees				
S _{r1}	Port1 Cable Refl. Stability ⁵	-70 dB (3.2×10^{-4})				
S _{t2}	Port2 Cable Trans. Phase Stability ⁵	0.05 × f (GHz) degrees				
S _{r2}	Port2 Cable Refl. Stability ⁵	-70 dB (3.2×10^{-4})				
T _{td}	Trans. Tracking Drift	Magnitude: 0.01 dB/°C (1.1×10^{-3} /°C)		Phase: ⁶ ±[0.1+0.15×f(GHz)]degrees/°C		
T _{rd}	Refl. Tracking Drift	Magnitude: 0.01 dB/°C (1.1×10^{-3} /°C)		Phase: ⁶ ±[0.1+0.15×f(GHz)]degrees/°C		
T _{sw}	Switch Tracking	±0.03 dB (3.5×10^{-3})				
M _{sw}	Switch Port Match	-70 dB (3.2×10^{-4})				

1 Accuracy enhancement procedures are performed using HP 85036B 75 Ω type-N calibration kit. Environmental temperature is 23°C ±3°C at calibration: ±1°C from calibration temperature must be maintained for valid measurement calibration.

2 With IF bandwidth of 10 Hz.

3 With impedance matched load.

4 High-level noise is the RMS of a continuous measurement of a short circuit or thru.

5 Arrived at by bending HP 11857D cables out perpendicular to front panel and reconnecting. Stability is much better with less flexing.

6 Arrived at using HP 11857D cables and full 2-port calibration. Drift is much better without cables and with 1-port calibration. For this case, drift typically is [0.1 + 0.05 × f (GHz)] × Δ°C, degrees.

Table 11-6.
 Typical System Performance for Devices with 50 Ω Type-N Connectors
 HP 4396B with HP 87512A Test Set (100 kHz to 1.8 GHz)

Symbol	Error Terms	Uncorrected	Typical Residual after Accuracy Enhancement ^{1, 2}			
			Response Only ³	Response and Isolation ³	One-Port	Full two port
D	Directivity	-	-	-	-40 dB (0.01)	-
M _s	Source Match	-24 dB (0.063)	-24 dB (0.063)	-24 dB (0.063)	-25 dB (0.056)	-25 dB (0.056)
T _r	Reflection Tracking	-	-	-	±0.83 dB (0.1)	±0.83 dB (0.1)
M _l	Load Match	-22 dB (0.079)	-22 dB ⁴ (0.079)	-22 dB (0.079)	-	-40 dB (0.01)
T _t	Trans. Tracking	±0.8 dB (0.096)	±0.2 dB (0.023)	±0.2 dB (0.023)	-	±0.05 dB (5.8×10 ⁻³)
C	Cross Talk	-	-	-	-110 dB (3.2×10 ⁻⁶)	-110 dB (3.2×10 ⁻⁶)
R _{r1}	Port1 Refl. Connector Repeatability	-65 dB (5.6×10 ⁻⁴)				
R _{t1}	Port1 Trans. Connector Repeatability	-65 dB (5.6×10 ⁻⁴)				
R _{r2}	Port2 Refl. Connector Repeatability	-65 dB (5.6×10 ⁻⁴)				
R _{t2}	Port2 Trans. Connector Repeatability	-65 dB (5.6×10 ⁻⁴)				
N _l	Low-Level Noise ²	-110 dB from full scale (3.2×10 ⁻⁶)				
N _h	High Level Noise ^{2,5}	Magnitude:0.003 dB (3.5×10 ⁻⁴)				
A _m ,A _p	Dynamic Accuracy Error	See "Dynamic Accuracy" in Chapter 10.				
U _m ,U _p	Multiplexer Switching Uncertainty	Magnitude:±0.017 dB (2.0 ×10 ⁻³) Phase:0.1 degrees				
S _{t1}	Port1 Cable Trans. Phase Stability ⁶	0.05 × f (GHz) degrees				
S _{r1}	Port1 Cable Refl. Stability ⁶	-70 dB (3.2×10 ⁻⁴)				
S _{t2}	Port2 Cable Trans. Phase Stability ⁶	0.05 × f (GHz) degrees				
S _{r2}	Port2 Cable Refl. Stability ⁶	-70 dB (3.2×10 ⁻⁴)				
T _{td}	Trans. Tracking Drift	Magnitude: 0.01 dB/°C (1.1×10 ⁻³ /°C)		Phase: ⁷ ±[0.1+0.15×f(GHz)]degrees/°C		
T _{rd}	Refl. Tracking Drift	Magnitude: 0.01 dB/°C (1.1×10 ⁻³ /°C)		Phase: ⁷ ±[0.1+0.15×f(GHz)]degrees/°C		

1 Accuracy enhancement procedures are performed using HP 85036B 75 Ω type-N calibration kit. Environmental temperature is 23°C ±3°C at calibration: ±1°C from calibration temperature must be maintained for valid measurement calibration.

2 With IF bandwidth of 10 Hz.

3 Transmission Only

4 @ f ≥ 500 kHz.

5 High-level noise is the RMS of a continuous measurement of a short circuit or thru.

6 Arrived at by bending HP 11857D cables out perpendicular to front panel and reconnecting. Stability is much better with less flexing.

7 Arrived at using HP 11857D cables and full 2-port calibration. Drift is much better without calbes and with 1-port calibration. For this case, drift typically is [0.1 + 0.05 × f (GHz)] × Δ°C, degrees.

Table 11-7.
Typical System Performance for Devices with 75 Ω Type-N Connectors
HP 4396B with HP 87512B Test Set (100 kHz to 1.8 GHz)

Symbol	Error Terms	Typical Residual after Accuracy Enhancement ^{1, 2}	
		One-Port	
D	Directivity	-40 dB (0.01)	
M _s	Source Match	-25 dB (0.056)	
T _r	Reflection Tracking	±0.83 dB (0.1)	
M _l	Load Match	-	
T _t	Trans. Tracking	-	
C	Cross Talk	±104 dB (6.3×10 ⁻⁶)	
R _{r1}	Port1 Refl. Connector Repeatability	-65 dB (5.6×10 ⁻⁴)	
R _{t1}	Port1 Trans. Connector Repeatability	-65 dB (5.6×10 ⁻⁴)	
R _{r2}	Port2 Refl. Connector Repeatability	-65 dB (5.6×10 ⁻⁴)	
R _{t2}	Port2 Trans. Connector Repeatability	-65 dB (5.6×10 ⁻⁴)	
N _l	Low-Level Noise ²	-94 dB from full scale (2.0×10 ⁻⁵)	
N _h	High Level Noise ^{2,3}	0.003 dB (3.5×10 ⁻⁴)	
A _m , A _p	Dynamic Accuracy Error	See "Dynamic Accuracy" in Chapter 10.	
U _m , U _p	Multiplexer Switching Uncertainty	Magnitude: 0.017 dB (2×10 ⁻³) Phase: 0.1 degrees	
S _{t1}	Port1 Cable Trans. Phase Stability ⁴	[0.05×f(GHz)] degrees	
S _{r1}	Port1 Cable Refl. Stability ⁴	-70 dB (3.2×10 ⁻⁴)	
S _{t2}	Port2 Cable Trans. Phase Stability ⁴	[0.05×f(GHz)] degrees	
S _{r2}	Port2 Cable Refl. Stability ⁴	-70 dB (3.2×10 ⁻⁴)	
T _{td}	Trans. Tracking Drift	Magnitude: 0.01 dB/°C (1.1×10 ⁻³ /°C)	Phase: ⁵ ±[0.1+0.15×f(GHz)] degrees/°C
T _{rd}	Refl. Tracking Drift	Magnitude: 0.01 dB/°C (1.1×10 ⁻³ /°C)	Phase: ⁵ ±[0.1+0.15×f(GHz)] degrees/°C

1 Accuracy enhancement procedures are performed using HP 85032B 50 Ω type-N calibration kit. Environmental temperature is 23°C ±3°C at calibration: ±1°C from calibration temperature must be maintained for valid measurement calibration.

2 With IF bandwidth of 10 Hz.

3 High-level noise is the RMS of a continuous measurement of a short circuit or thru.

4 Arrived at by bending HP 11857D cables out perpendicular to front panel and reconnecting. Stability is much better with less flexing.

5 Arrived at using HP 11857D cables and full 2-port calibration. Drift is much better without calbes and with 1-port calibration. For this case, drift typically is [0.1 + 0.05 × f (GHz)] × Δ°C, degrees.

Determining Expected System performance

The uncertainty equations, dynamic accuracy calculations, and tables of system performance values provided in the preceding pages can be used to calculate the expected system performance. The following pages explain how to determine the residual errors of a particular system and combine them to obtain total error-corrected residual uncertainty values, using worksheets provided. The uncertainty graphs at the beginning of this *System performance* section are examples of the results that can be calculated using this information.

Procedures

Table 11-8 is a worksheet used to calculate the residual uncertainty in reflection measurements. Table 11-9 is a worksheet for residual uncertainty in transmission measurements. Determine the linear values of the residual error terms and the nominal linear S-parameter data of the device under test as described below and enter these values in the worksheets. Then use the instructions and equations in the worksheets to combine the residual errors for total system uncertainty performance.

S-parameter Values. Convert the S-parameters of the test device to their absolute linear terms.

Noise Floor. See the *Receiver Noise Level Performance Test* in the *Performance Test Manual* to determine the actual noise floor performance of your measurement setup.

Crosstalk. See the *Input Crosstalk Performance Test*. Connect an impedance-matched load to each of the test ports and measure S_{21} or S_{12} after calibration. Turn on the marker statistics function (see Chapter 7, and measure the mean value of the trace. Use the mean value plus one standard deviation as the residual crosstalk value of your system.

Dynamic Accuracy. Determine the absolute linear magnitude dynamic accuracy as described under *Dynamic Accuracy* In this chapter.

Other Error Terms. See Table 11-2 through Table 11-7, depending on the test set and connector type in your system. Find the absolute linear magnitude of the remaining error terms.

Combining Error Terms. Combine the above terms using the reflection or transmission uncertainty equation in the worksheets.

Table 11-8. Reflection Measurement Uncertainty Worksheet

In the columns below, enter the appropriate values for each term. Frequency: _____			
Error Term	Symbol	dB Value	Linear Value
Directivity	D		
Reflection tracking	T_r		
Source match	M_s		
Load match	M_l		
Dynamic accuracy (magnitude) ¹	A_m		
Dynamic accuracy (phase) ¹	A_p		
Multiplexer Switching Uncertainty (magnitude)	U_m		
Multiplexer Switching Uncertainty (phase)	U_p		
S_{11}	S_{11}		
S_{21}	S_{21}		
S_{12}	S_{12}		
Noise floor	N_l		
High level noise	N_h		
Connector reflection repeatability	R_{r1}, R_{r2}		
Connector transmission repeatability	R_{t1}, R_{t2}		
Magnitude drift due to temperature	$T_{rd}(\text{mag})$		
Phase drift due to temperature	$T_{rd}(\text{phase})$		
Cable reflection stability	S_{r1}, S_{r2}		
Cable transmission phase stability	S_{t1}, S_{t2}		
Switch Tracking	T_{sw}		
Switch Port Match	M_{sw}		
Magnitude			
Combine Systematic Errors. In the space provided, enter the appropriate linear values from the list of errors. Then combine these errors to obtain the total sum of systematic errors.			
$(1 + T_{sw}) \times (D + S_{r1})$	$(\text{_____} + \text{_____}) \times (\text{_____} + \text{_____}) = \text{_____} \quad (\text{k})$		
$(T_{sw} + T_r) \times S_{11}$	$(\text{_____} + \text{_____}) \times \text{_____} = \text{_____} \quad (\text{l})$		
$(M_{sw} + S_{r1} + M_s) \times S_{11} \times S_{11}$	$(\text{_____} + \text{_____} + \text{_____}) \times \text{_____} \times \text{_____} = \text{_____} \quad (\text{m})$		
$(M_{sw} + S_{r2} + M_l) \times S_{21} \times S_{12}$	$(\text{_____} + \text{_____} + \text{_____}) \times \text{_____} \times \text{_____} = \text{_____} \quad (\text{n})$		
$(A_m + U_m) \times S_{11}$	$(\text{_____} + \text{_____}) \times \text{_____} = \text{_____} \quad (\text{o})$		
Subtotal: k + l + m + n + o	$\text{_____} + \text{_____} + \text{_____} + \text{_____} + \text{_____} = \text{_____} \quad (\text{S})$		
Combine Random Errors. In the space provided, enter the appropriate linear values from the list of errors. Then combine these errors in an RSS fashion to obtain a total sum of the random errors.			
$3 \times N_l$	$3 \times \text{_____} = \text{_____} \quad (\text{w})$		
$3 \times N_h \times S_{11}$	$3 \times \text{_____} \times \text{_____} = \text{_____} \quad (\text{x})$		
$R_{r1} + 2 \times R_{t1} \times S_{11} + R_{r1} \times S_{11} \times S_{11}$	$\text{_____} + 2 \times \text{_____} \times \text{_____} + \text{_____} \times \text{_____} \times \text{_____} = \text{_____} \quad (\text{y})$		
$R_{r2} \times S_{21} \times S_{12}$	$\text{_____} \times \text{_____} \times \text{_____} = \text{_____} \quad (\text{z})$		
$\sqrt{w^2 + x^2 + y^2 + z^2}$	$\sqrt{\text{_____} \times \text{_____} + \text{_____} \times \text{_____} + \text{_____} \times \text{_____} + \text{_____} \times \text{_____}} = \text{_____} \quad (\text{R})$		
Subtotal: S + R	$\text{_____} + \text{_____} = \text{_____} \quad (\text{V}_r)$		
Total Magnitude Errors:			
$E_{rm}(\text{linear}) = V_r + T_{rd}(\text{mag}) \times S_{11}$	$\text{_____} + (\text{_____} \times \text{_____}) = \text{_____}$		
$E_{rm}(\text{log}) = 20 \text{Log}(1 \pm E_{rm}/S_{11})$	$20 \text{Log}(1 \pm \text{_____} / \text{_____}) = \text{_____} \text{ dB}$		
Phase			
$E_{rp} = \text{Arcsin}\{V_r - (A_m + U_m) \times S_{11}/S_{11}\} + T_{rd}(\text{phase}) + 2 \times S_{t1} + A_p + U_p$	$\text{Arcsin}\{(\text{_____} - (\text{_____} + \text{_____}) \times \text{_____}) / \text{_____}\} + \text{_____} + 2 \times \text{_____} + \text{_____} + \text{_____} = \pm \text{_____} \text{ deg.}$		

¹ With IF bandwidth of 10 Hz.

Table 11-9. Transmission Measurement Uncertainty Worksheet

In the columns below, enter the appropriate values for each term. Frequency: _____			
Error Term	Symbol	dB Value	Linear Value
Crosstalk	C	_____	_____
Transmission tracking	T _t	_____	_____
Source match	M _s	_____	_____
Load match	M _l	_____	_____
Dynamic accuracy (magnitude) ¹	A _m	_____	_____
Dynamic accuracy (phase) ¹	A _p	_____	_____
Multiplexer Switching Uncertainty (magnitude)	U _m	_____	_____
Multiplexer Switching Uncertainty (phase)	U _p	_____	_____
S ₁₁	S ₁₁	_____	_____
S ₂₁	S ₂₁	_____	_____
S ₁₂	S ₁₂	_____	_____
S ₂₂	S ₂₂	_____	_____
Noise floor	N _i	_____	_____
High level noise	N _h	_____	_____
Connector reflection repeatability	R _{r1} , R _{r2}	_____	_____
Connector transmission repeatability	R _{t1} , R _{t2}	_____	_____
Magnitude drift due to temperature	T _{td} (mag)	_____	_____
Phase drift due to temperature	T _{td} (phase)	_____	_____
Cable reflection stability	S _{r1} , S _{r2}	_____	_____
Cable transmission phase stability	S _{t1} , S _{t2}	_____	_____
Switch Tracking	T _{sw}	_____	_____
Switch Port Match	M _{sw}	_____	_____
Magnitude			
Combine Systematic Errors. In the space provided, enter the appropriate linear values from the list of errors. Then combine these errors to obtain the total sum of systematic errors.			
C	_____ = _____ (k)		
(T _{sw} + T _t) × S ₂₁	(_____ + _____) × _____ = _____ (l)		
(M _{sw} + S _{r1} + M _s) × S ₁₁ × S ₂₁	(_____ + _____ + _____) × _____ × _____ = _____ (m)		
(M _{sw} + S _{r2} + M _l) × S ₂₁ × S ₂₂	(_____ + _____ + _____) × _____ × _____ = _____ (n)		
(A _m + U _m) × S ₂₁	(_____ + _____) × _____ = _____ (o)		
Subtotal: k + l + m + n + o	_____ + _____ + _____ + _____ + _____ = _____ (S)		
Combine Random Errors. In the space provided, enter the appropriate linear values from the list of errors. Then combine these errors in an RSS fashion to obtain a total sum of the random errors.			
3 × N _i	3 × _____ = _____ (w)		
3 × N _h × S ₂₁	3 × _____ × _____ = _____ (x)		
R _{t1} × S ₂₁ + R _{r1} × S ₁₁ × S ₂₁	_____ × _____ + _____ × _____ × _____ = _____ (y)		
R _{t2} × S ₂₁ + R _{r2} × S ₂₂ × S ₂₁	_____ × _____ + _____ × _____ × _____ = _____ (z)		
$\sqrt{w^2 + x^2 + y^2 + z^2}$	$\sqrt{\text{_____}^2 + \text{_____}^2 + \text{_____}^2 + \text{_____}^2} = \text{_____}$ (R)		
S + R	_____ + _____ = _____ (V _t)		
Total Magnitude Errors:			
E _{tm} (linear) = V _t + T _{td} (mag) × S ₂₁	_____ + (_____ × _____) = _____		
E _{tm} (log) = 20 Log(1 ± E _{tm} /S ₂₁)	20 Log(1 ± _____ / _____) = _____ dB		
Phase			
E _{tp} = Arcsin[(V _t - (A _m + U _m) × S ₂₁)/S ₂₁] + T _{td} (phase) + S _{r1} + S _{r2} + A _p + U _p	Arcsin[(_____ - (_____ + _____) × _____) / _____] + _____ + _____ + _____ + _____ + _____ = ± _____ deg.		

¹ With IF bandwidth of 10 Hz.

Analyzer Features

This chapter provides additional information on analyzer features beyond the basic concepts covered in the previous chapters.

The following subjects are covered in this chapter:

- System Overview
- Data Processing Flow
- Network Analyzer Basic
 - Network Measurement Basic
 - S-parameters
 - Conversion
 - Smith Chart
 - Polar Chart
 - Electrical Delay
 - Averaging
 - IF Band Reduction
 - Group Delay
- Spectrum Analyzer Basic
 - Detection Mode
 - Swept and FFT Mode
 - Resolution Bandwidth (RBW)
 - Selectivity of the RBW
 - Noise Measurement
 - Reference Level Calibration
 - Spectrum Monitor at inputs R, A, and B
- Measurement and Display Points
- Channel Coupling
- Limit Line Concept
- Gated Sweep for Spectrum Measurement
- Repetitive Sampling
- Marker
- HP-IB
- Calibration for Network Measurement
- I/O Port

System Overview

The analyzer has two measurement modes of operation; a network analyzer mode and a spectrum analyzer mode. Network analyzers measure the reflection and transmission characteristics of devices and networks by applying a known swept signal and measuring the response of the test device. The signal transmitted through the device or reflected from its input is compared with the incident signal generated by a swept RF source. The signals are applied to a receiver for measurement, signal processing, and display. A network analyzer system consists of a source, signal separation devices, a receiver, and a display.

Spectrum analyzers measure the amplitude and frequency of a signal spectral line by sweeping the tuning frequency of the receiver. The test signal is applied to a receiver through an input attenuator. A spectrum analyzer consists of an input attenuator, a receiver, and a display.

Figure 12-1 is a simplified block diagram of the analyzer. A detailed block diagram of the analyzer is provided in the *Service Manual*, together with a complete theory of system operation.

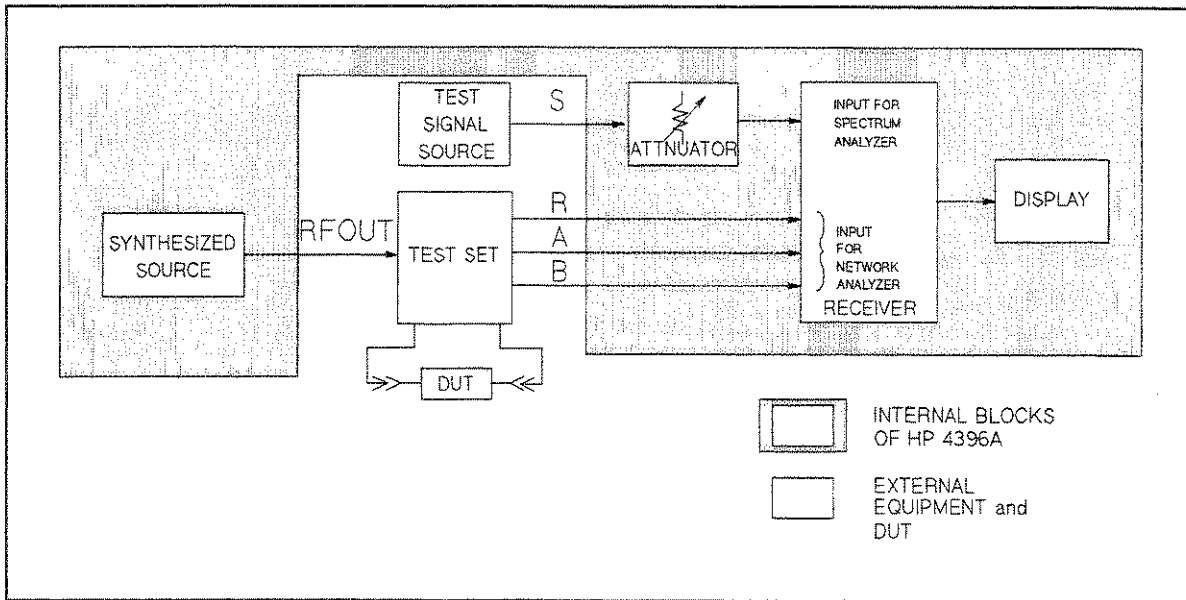

Figure 12-1. Analyzer Simplified Block Diagram

Data processing

Overview

The analyzer's receiver converts the R, A, B, or S input signals into useful measurement information. This conversion occurs in two main steps. First, the high frequency input signal is translated to fixed low frequency IF signals using analog mixing techniques. See the "Theory of Operation" in the *Service Manual* for details. Second, the IF signals are converted into digital data by an analog-to-digital converter (ADC). From this point on, all further signal processing is performed mathematically by the analyzer microprocessor and digital signal processor. The following paragraphs describe the sequence of math operations and the resulting data arrays as the information flows from the ADC to the display. They provide a good foundation for understanding most of the measurement functions and the order in which they are performed.

The analyzer has two data processing flow paths. One is for network analyzer mode and the other is for spectrum analyzer mode. The data flow is automatically changed when analyzer mode is changed. Additionally, the data flow of the spectrum analyzer mode has two flow paths. One is for stepped FFT mode ($RBW \leq 3$ kHz) and the other is for swept mode ($RBW \geq 10$ kHz). (For more information on stepped

FFT and swept mode, see "Swept Mode and FFT Mode" in this chapter.

Figure 12-2 and Figure 12-3 are data processing flow diagrams that represent the flow of numerical data from IF detection to display. The data passes through several math operations (shown as single-line boxes). Most of these operations can be selected and controlled by the front panel MEASUREMENT block menus. The data is also stored in data arrays (shown as double-line boxes). These arrays are places in the flow path where the data is accessible via HP-IB or using the internal disk drive or the RAM disk memory.

Note



While only a single flow path is shown, two identical paths are available that correspond to channel 1 and channel 2. When the channels are uncoupled, each channel can be independently controlled so that the data processing operations for one can be different from the other.

Data Processing for Network Measurement

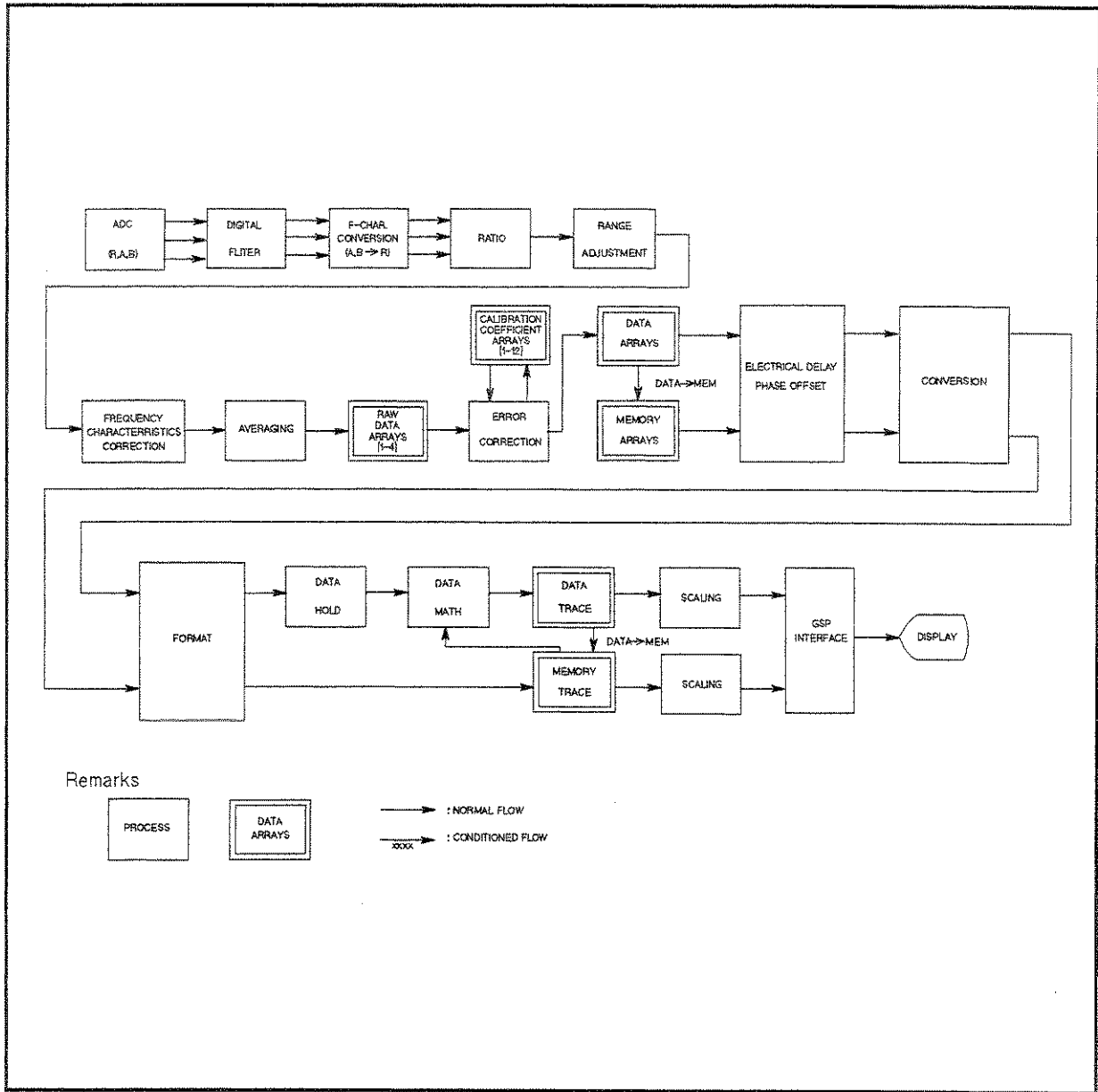

C5072/020

Figure 12-2. Data Processing for Network Measurement

AD converter (ADC)

The ADC converts an analog signal (which is already down-converted to a fixed low frequency IF) into digital data.

Digital Filter

The digital filter detects the IF signal by performing a discrete Fourier transform (DFT) on the digital data. The samples are converted into complex number pairs (real plus imaginary, $R + jI$) that represent both the magnitude and phase of the IF signal. The filter shape can be altered

by selecting the IF bandwidth in Hz from the 10, 30, 100, 300, 1 k, 3 k, 10 k, and 40 k choices. Changing the filter shape is a highly effective technique for noise reduction.

Frequency characteristics conversion

This process digitally corrects for frequency response errors in the analog down-conversion path.

Ratio Calculations

These calculations are performed if the selected measurement is a ratio of two inputs (for example, A/R or B/R). This is simply a complex divide operation. If the selected measurement is absolute (for example, A or B), no operation is performed. The R, A, and B values are also split into channel data at this point.

Range Adjustment

This corrects the value to what it was before being ranged. The correction is required because the input signal is ranged before it is input to the ADC.

Frequency Characteristics Correction

This corrects the frequency response for absolute measurement value. If the selected measurement is ratio (for example, A/R or B/R), no operation is performed.

Averaging

This is one of the noise reduction techniques. This calculation involves taking the complex exponential average of up to 999 consecutive sweeps. See “Averaging” in this chapter.

Raw Data Arrays

These arrays store the results of all the preceding data processing operations. When full 2-port error correction is on, the raw data arrays contain all four S-parameter measurements required for accuracy enhancement. When the channels are uncoupled (coupled channels OFF), there may be as many as eight raw data arrays. These arrays are directly accessible via HP-IB, or using the internal disk drive or the RAM disk memory. Note that the numbers here are still complex pairs.

Calibration Coefficient Arrays

When a measurement calibration has been performed and correction is turned on, error correction removes the repeatable systematic errors (stored in the calibration coefficient arrays) from the raw data arrays. This can vary from simple vector normalization to full 12-term error correction. See “**Cal**” in Chapter 5 and “Calibration for Network Measurement” for details.

The calibration coefficient arrays themselves are created during a measurement calibration using data from the raw data arrays. These are subsequently used whenever correction is on, and are accessible via HP-IB, or using the internal disk drive or the RAM disk memory.

Data Arrays

The results of error correction are stored in the data arrays as complex number pairs. These arrays are accessible via HP-IB or by using the internal disk drive or the RAM disk memory.

Memory Arrays

If the data-to-memory operation is performed, the data arrays are copied into the memory arrays (data trace arrays are also copied into the memory trace array at same time). See “**Display**” in Chapter 5 in this chapter. These arrays are accessible using the internal disk drive

or the RAM disk memory. These arrays are also output via HP-IB, but data cannot be input into this array via HP-IB.

If memory is displayed, the data from the memory arrays goes through the same data processing flow path as the data from the data arrays.

Electrical Delay and Phase Offset

This involves adding or subtracting a linear phase in proportion to frequency. This is equivalent to “line-stretching” or artificially moving the measurement reference plane. See “Electrical Delay” for details.

Conversion

Transforms S-parameter measurement data into equivalent complex impedance (Z) or admittance (Y) values, to inverse S-parameters (1/S), or to phase multiples of 4, 8, or 16. See “Conversion Function” in this chapter.

Format

This converts the complex number pairs into a scalar representation for display, according to the selected format. This includes group delay calculations. These formats are often easier to interpret than the complex number representation. (Polar and Smith chart formats are not affected by the scalar formatting.) Note that after formatting, it is impossible to recover the complex data. See “Group Delay” for information on group delay principles.

Data Hold

This keeps the maximum or minimum value at each display point when the data hold function is turned on.

Data Math

This calculates the complex ratio of the two (data/memory), the difference (data–memory), or summation (data+memory) when the data math function is selected. In addition, this function multiplies the ratio, difference, or summation by a constant, or subtracts a constant from them.

Data Trace Arrays

The results are stored in the data trace arrays. It is important to note those marker values and marker functions are all derived from the data trace arrays. Limit testing is also performed on this array. The data trace arrays are accessible via HP-IB, or using the internal disk drive or the RAM disk memory.

Memory Trace Arrays

If the data-to-memory operation is performed, the data trace arrays are copied into the memory trace arrays (data arrays are also copied into the memory array at same time). These arrays are accessible using the internal disk drive or the RAM disk memory. These arrays are also output via HP-IB, but data cannot be input into these arrays via HP-IB.

Scaling

These operations prepare the formatted data for display on the CRT. This is where the appropriate reference line position, reference line value, and scale calculations are performed. See “Scale Ref” in Chapter 5 in this chapter.

Data Processing for Spectrum Measurement

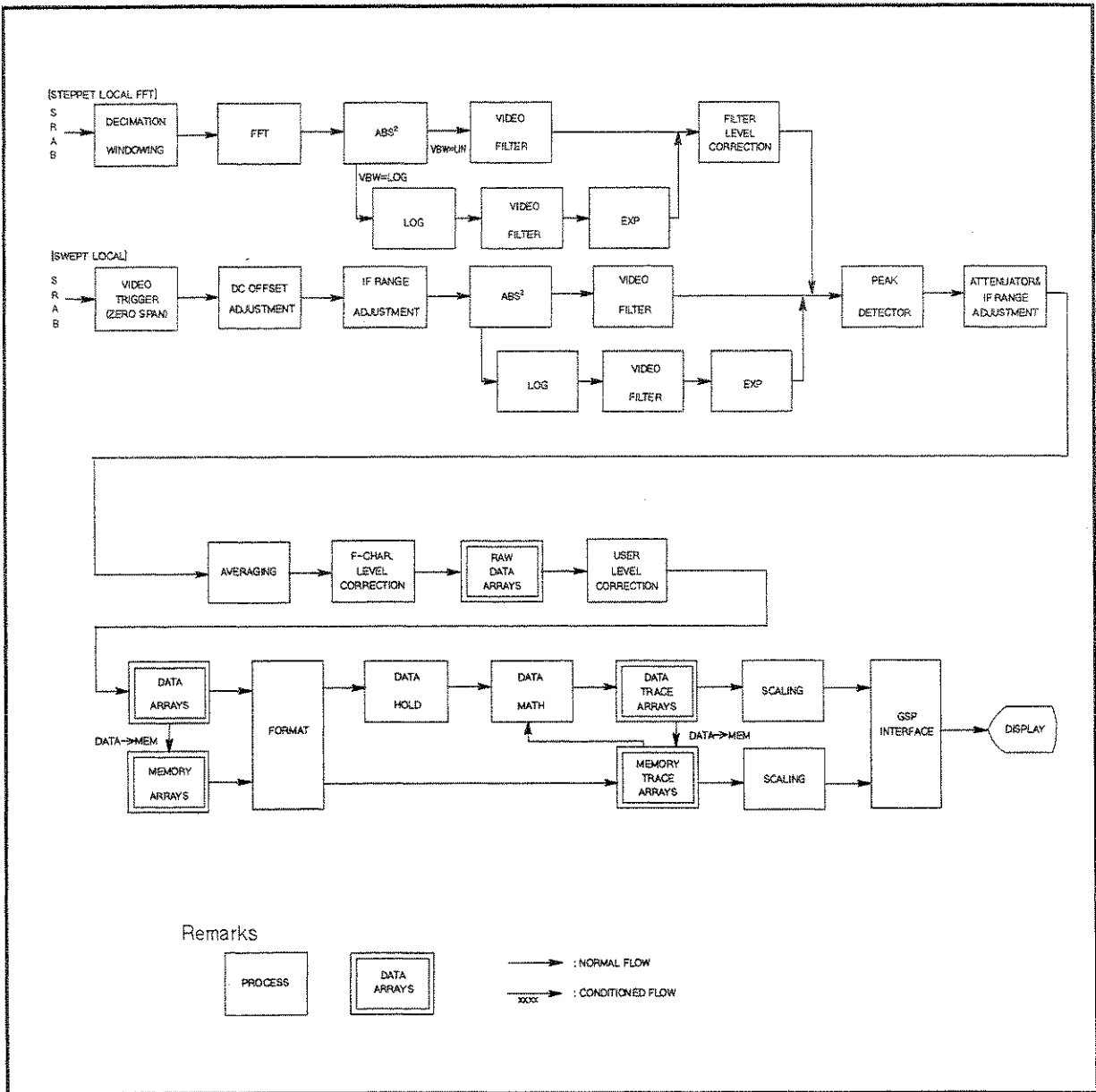

C502046

Figure 12-3. Data Processing for Spectrum Measurement

Decimation Windowing

This function reduces the sampling rate to resolve the spectrum closer than the frequency resolution (which is decided by an inherent sampling rate and finite sampling number). In other words, this process allows any frequency resolution to be set using an inherent sampling rate in FFT.

Fast Fourier Transform (FFT)

This operation transforms a time domain signal into a frequency domain data using the Fast Fourier Transform.

Absolute Squared

This calculates the power of the spectrum.

Video Averaging

Video Averaging is one of the noise reduction techniques. The video bandwidth can be selected to be RBW/1, RBW/3, RBW/10, RBW/100, or RBW/300.

Filter Level Correction

This correction removes the error caused by the passband ripple of the crystal filter (IF filter).

Video Trigger

If SPAN is set to ZERO, the video trigger is available. This triggers the measurement when the amplitude of signal measured is over the threshold value.

DC Offset Correction

This cancels the dc offset generated in the phase detector and sample/hold block of the analog circuit.

IF Range Adjustment

This adjustment corrects the value to what it was before being ranged by the IF block.

Peak Detector

This detects the peak value of the displayed points. Three detection modes are provided, the positive, negative, and sample mode. See "Detection Mode" for information on detection techniques.

Attenuator and IF Range Adjustment

This adjustment corrects the value to what it was before being attenuated and ranged.

Averaging

This is the same as Averaging in the data processing flow for the network measurement.

Frequency Characteristics Level Correction

This process digitally corrects for frequency response errors in the analog down-conversion path.

Raw Data Arrays

These arrays store the results of all the data produced by the peak detector. These arrays are directly accessible via HP-IB or by using the internal disk drive or the RAM disk memory.

User Level Correction

This correction cancels the offset error level.

Data Arrays

The results of error correction are stored in the data arrays. These arrays are accessible via HP-IB or by using the internal disk drive or the RAM disk memory.

Memory Arrays

If the data-to-memory operation is performed, the data arrays are copied into the memory arrays (data trace arrays are also copied into the memory trace arrays at same time). See **Display** in chapter 5. These arrays are accessible using the internal disk drive or the RAM disk memory. These arrays are also output via HP-IB, but data cannot be input into these arrays via HP-IB.

If memory is displayed, the data from the memory arrays goes through the same data processing flow path as the data from the data arrays.

Format/Unit conversion

This converts the measured values (dB value) to other unit (dBV, dB μ V, watt, and volt). When noise measurement is selected, this divides measured values by the equivalent noise bandwidth to measure noise level directly.

Data Hold

This is the same as the Data Hold in the data processing flow for the network measurement.

Data Math

This is the same as the Data Math in the data processing flow for the network measurement.

Data Trace Array

This is the same as the data trace array in the data processing flow for the network measurement.

Memory Trace Array

This is the same as the memory trace array in the data processing flow for the network measurement.

Scaling

This is the same as the scaling in the data processing flow for the network measurement.

Network Measurement Basics

S-parameters

S-parameters (scattering parameters) are a convention that characterizes the way a device modifies signal flow. A brief explanation is provided here of the S-parameters of a two-port device. For additional details see Hewlett-Packard Application Notes *A/N 95-1* and *A/N 154*.

S-parameters are always a ratio of two complex (magnitude and phase) quantities. S-parameter notation identifies these quantities using the numbering convention:

$$S_{\text{out in}}$$

Where the first number (**out**) refers to the port where the signal is emerging and the second number (**in**) is the port where the signal is incident. For example, the S-parameter S_{21} identifies the measurement as the complex ratio of the signal emerging at port 2 to the signal incident at port 1.

Figure 12-4 is a representation of the S-parameters of a two-port device, together with an equivalent flow graph. In the illustration, "a" represents the signal entering the device and "b" represents the signal emerging. Note that a and b are not related to the A and B input ports on the analyzer.

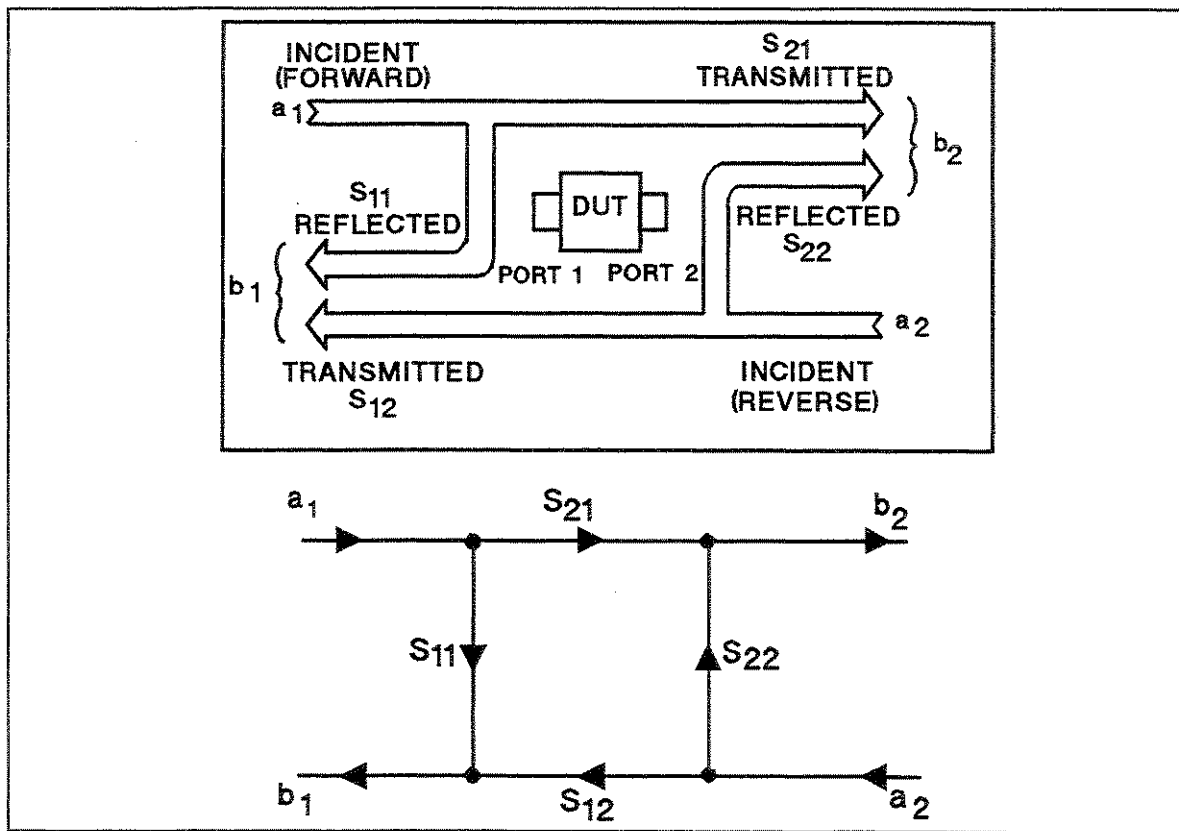

Figure 12-4. S-Parameters of a Two-Port Device

S-parameters are exactly equivalent to the more common description terms below, requiring only that the measurements are taken with all DUT ports properly terminated.

S-Parameter	Definition	Test Set Description	Direction
S_{11}	$\frac{b_1}{a_1} _{a_2=0}$	Input reflection Coefficient	FWD
S_{21}	$\frac{b_2}{a_1} _{a_2=0}$	Forward gain	FWD
S_{12}	$\frac{b_1}{a_2} _{a_1=0}$	Reverse gain	REV
S_{22}	$\frac{b_2}{a_2} _{a_1=0}$	Output reflection coefficient	REV

Conversion Function

This function converts the measured reflection or transmission data to the equivalent complex impedance (Z) or admittance (Y) values. This is not the same as a two-port Y or Z parameter conversion, as only the measured parameter is used in the equations. Two simple one-port conversions are available, depending on the measurement configuration.

An S_{11} or S_{22} trace measured as reflection can be converted to an equivalent parallel impedance or admittance using the model and equations shown in Figure 12-5.

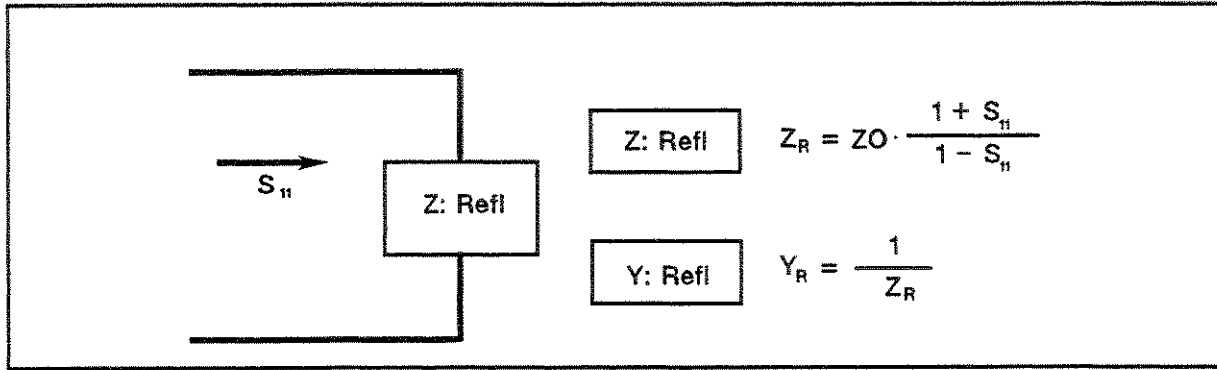

Figure 12-5. Reflection Impedance and Admittance Conversions

In a transmission measurement, the data can be converted to its equivalent series impedance or admittance using the model and equations shown in Figure 12-6.

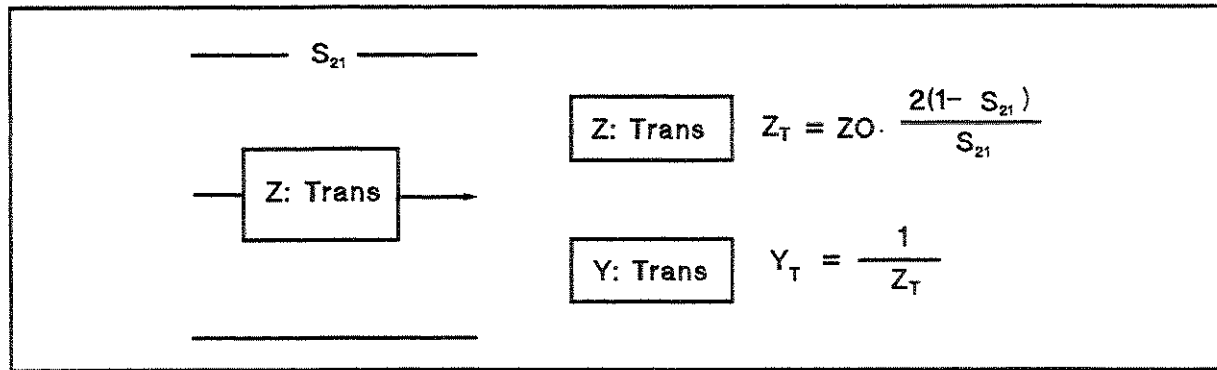

Figure 12-6. Transmission Impedance and Admittance Conversions

Avoid using Smith chart, SWR, and delay formats for displaying Z and Y conversions, as these formats are not easily interpreted.

Marker values are impedance values in Ω units for Z conversions, or admittance values in S units for Y conversions in any format.

Smith Chart

A Smith chart is used in reflection measurements to provide a readout of the data in terms of impedance. The intersecting lines on the Smith chart represent constant resistance and constant reactance values, normalized to the characteristic impedance, Z_0 , of the system. Reactance values in the upper half of the Smith chart circle are positive (inductive) reactance, and in the lower half of the circle are negative (capacitive) reactance.

Polar Chart

Each point on the polar format corresponds to a particular value of both magnitude and phase. Quantities are read vectorally: the magnitude at any point is determined by its displacement from the center (which has zero value), and the phase by the angle counterclockwise from the positive x-axis. Magnitude is scaled in a linear fashion, with the value of the outer circle usually set to a ratio value of 1. Because there is no frequency axis, frequency information is read from the markers.

Electrical Delay

The electrical delay function simulates a variable length lossless transmission line that can be added to or removed from a receiver input to compensate for interconnecting cables, etc. This function is similar to the mechanical or analog "line stretchers" of other network analyzers. Delay is annotated in units of time with secondary labeling in distance for the current velocity factor.

An equivalent length of air is added or subtracted according to the following formula:

$$\text{Length (meters)} = \frac{\phi}{\text{Frequency (MHz)} \times 1.20083}$$

Once the linear portion of the DUT's phase has been removed, the equivalent length of air can be read out in the active entry area. If the average relative permittivity (ϵ_r) of the DUT is known over the frequency span, the length calculation can be adjusted to indicated the actual length of the DUT more closely. This can be done by entering the relative velocity factor for the DUT using **VELOCITY FACTOR** softkey under **[Cal]** key. The relative velocity factor for a given dielectric can be calculated by:

$$\text{Velocity factor} = \frac{1}{\sqrt{\epsilon_r}}$$

assuming a relative permeability of 1.

Averaging

Averaging computes each data point based on an exponential average of consecutive sweeps weighted by a user-specified averaging factor. Each new sweep is averaged into the trace until the total number of sweeps is equal to the averaging factor, for a fully averaged trace. Each point on the trace is the vector sum of the current trace data and the data from the previous sweep. A high averaging factor gives the best signal-to-noise ratio, but slows the trace update time. Doubling the averaging factor reduces the noise by 3 dB. The algorithm used for averaging is:

$$A_{(n)} = \frac{S_{(n)}}{F} + \left(1 - \frac{1}{F}\right) \times A_{(n-1)}$$

where

$A(n)$ = current average

$S(n)$ = current measurement

F = average factor

IF Band Reduction

IF bandwidth reduction lowers the noise floor by reducing the receiver input bandwidth. It has an advantage over averaging in reliably filtering out unwanted responses such as spurs, odd harmonics, higher frequency spectral noise, and line-related noise. Sweep-to-sweep averaging, however, is better at filtering out very low frequency noise. A tenfold reduction in IF bandwidth (from 200 Hz to 20 Hz, for example) lowers the measurement noise floor by about 10 dB.

Another difference between sweep-to-sweep averaging and variable IF bandwidth is the sweep time. Averaging displays the first complete trace faster but takes several sweeps to reach a fully averaged trace. IF bandwidth reduction lowers the noise floor in one sweep, but the sweep time may be slower.

Group Delay

For many networks, the amount of insertion phase is not as important as the linearity of the phase shift over a range of frequencies.

The analyzer can measure this linearity and express it in two different ways: directly, as deviation from linear phase, or as group delay, a derived value. See the **SCALE REF** key description in this chapter for information on deviation from linear phase.

Group delay is the measurement of signal transmission time through a test device. It is defined as the derivative of the phase characteristic with respect to frequency. Because the derivative is the instantaneous slope (or rate of change of phase with frequency), a perfectly linear phase shift results in a constant slope, and therefore a constant group delay (Figure 12-7).

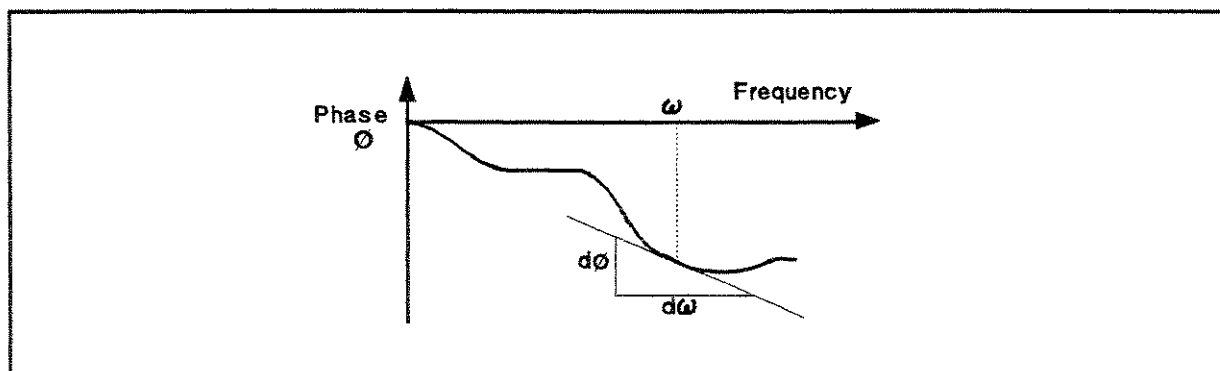
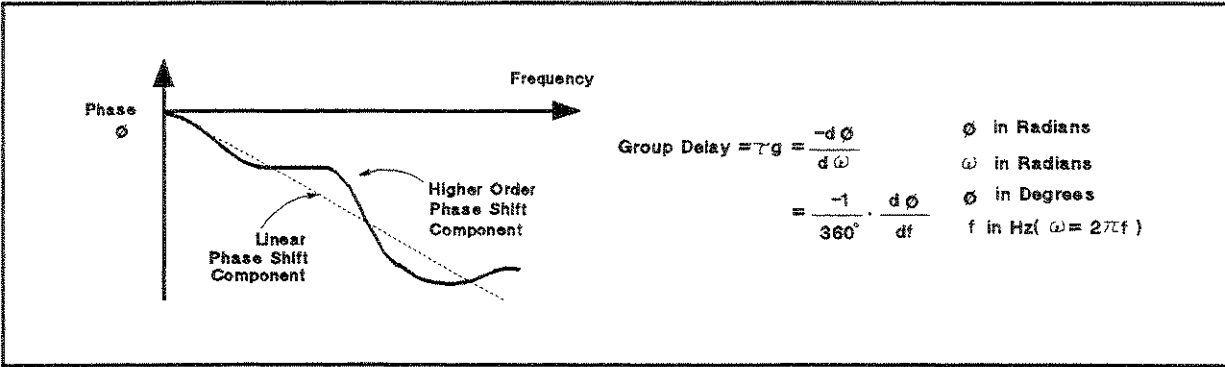

Figure 12-7. Constant Group Delay

Note, however, that the phase characteristic typically consists of both linear (first order) and higher order (deviations from linear) components. The linear component can be attributed to the electrical length of the test device and represents the average signal transit time. The higher order components are interpreted as variations in transit time for different frequencies, and represent a source of signal distortion (Figure 12-8).



C5012002

Figure 12-8. Higher Order Phase Shift

The analyzer computes group delay from the phase slope. Phase data is used to find the phase deviation, $\Delta\phi$, at the center point of a specified frequency aperture, Δf , to obtain an approximation for the rate of change of phase with frequency (Figure 12-9). This value, τ_g , represents the group delay in seconds assuming linear phase change over Δf .

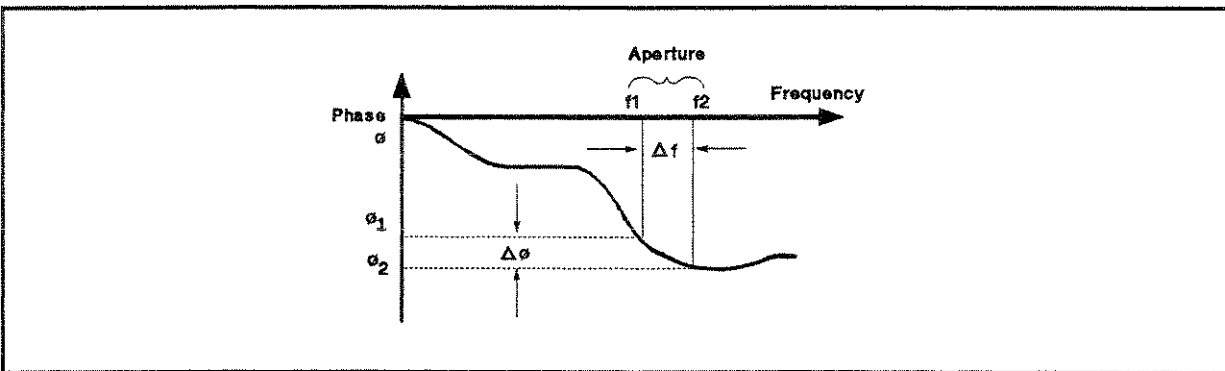

C5012003

Figure 12-9. Rate of Phase Change Versus Frequency

When deviations from linear phase are present, changing the frequency step can result in different values for group delay. Note that in this case the computed slope varies as the aperture Δf is increased (Figure 12-10). A wider aperture results in loss of the fine grain variations in group delay. This loss of detail is the reason that in any comparison of group delay data it is important to know the aperture used to make the measurement.

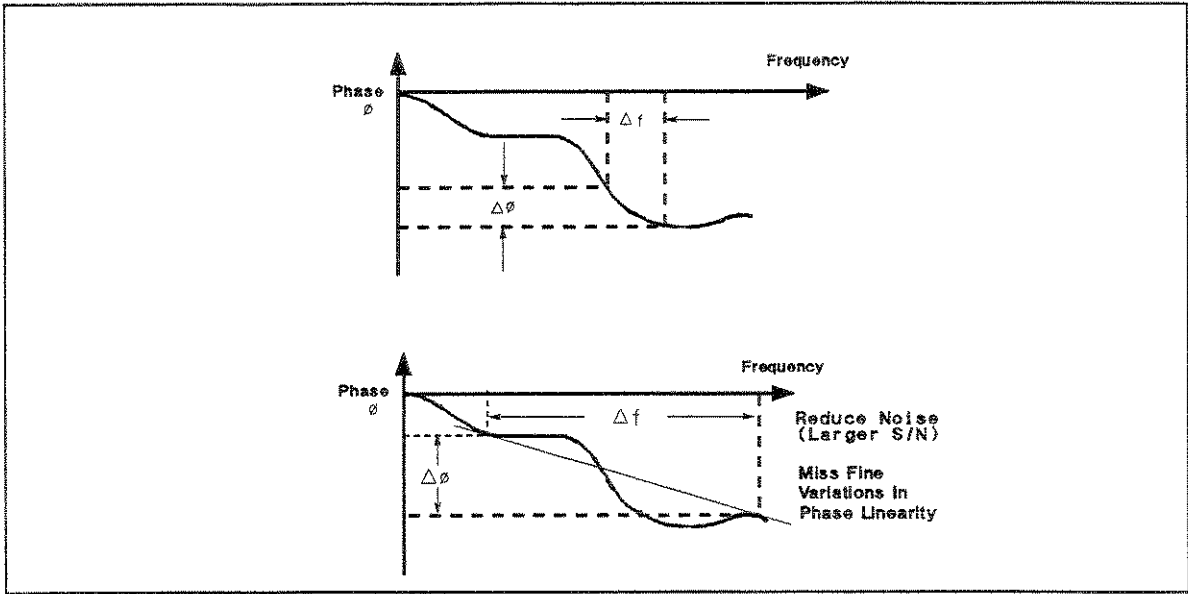

CS012004

Figure 12-10. Variations in Frequency Aperture

In determining the group delay aperture, there is a tradeoff between resolution of fine detail and the effects of noise. Noise can be reduced by increasing the aperture, but this will tend to smooth out the fine detail. More detail will become visible as the aperture is decreased, but the noise will also increase, possibly to the point of obscuring the detail. A good practice is to use a smaller aperture to assure that small variations are not missed, then increase the aperture to smooth the trace.

Spectrum Measurement Basics

Detection Modes

The analyzer displays the value measured at the display point specified by NOP. However, analyzer sweeps with the resolution specified by RBW. Detection chooses one level measured between display points for displaying the trace. One of three detection modes can be selected:

Positive and Negative Peak Modes

Positive and negative peak modes store signal maximums and minimums between the display points, respectively, in a data array.

Sample Mode

In the sample mode, the signal value at the display point is placed in a data array. Sample mode is used to measure noise level.

Swept Mode and FFT Mode

Usually, two analyzers are used to analyze waveforms transformed from the time domain test signal to the frequency domain; one is a swept spectrum analyzer and the other is an FFT analyzer.

When measuring signals over a wide frequency span with a wide RBW, swept spectrum analyzers are better than FFT analyzers. This is true because the FFT analyzer requires a large memory and a fast AD converter to measure the signal and therefore, is not practical. When measuring signals with narrow RBW, FFT analyzers are better than swept spectrum analyzers because the swept spectrum analyzer requires much more time to measure (sweep) the signal. The FFT analyzer can measure the signal in very short time.

The HP 4396A analyzer uses both the swept spectrum analyzer and the FFT analyzer modes. The two modes (swept mode and FFT mode) are automatically selected. Swept mode is selected if RBW is ≥ 10 kHz and FFT mode is selected if RBW is ≤ 3 kHz.

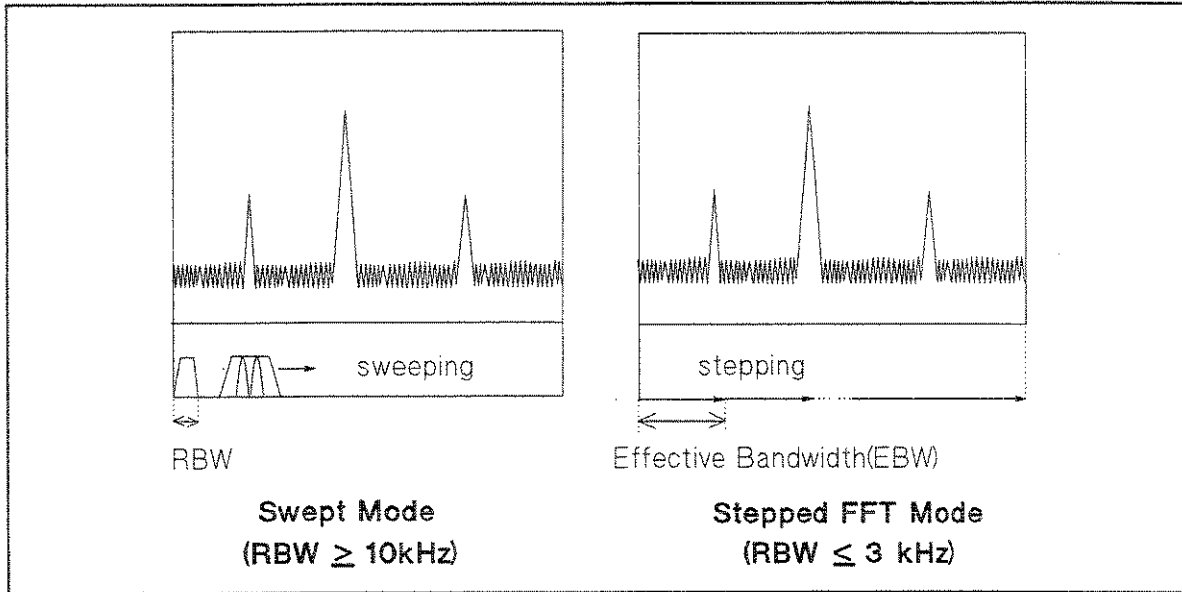

C5012032

Figure 12-11. Swept Mode and Stepped FFT Mode

Selectivity of the RBW

The selectivity of the RBW is the ratio of the 60 dB bandwidth to 3 dB bandwidth (RBW) of the filter. The selectivity defines the shape of the filter. This factor is important when resolving small signal that is adjacent to a large signal. The small adjacent signal is hidden by the large signal even when the resolution bandwidth is set to smaller than the difference of frequency between the signals. To resolve small adjacent signals, the resolution bandwidth must be set so that the small signal is not hidden by the large signals as shown in Figure 12-12.

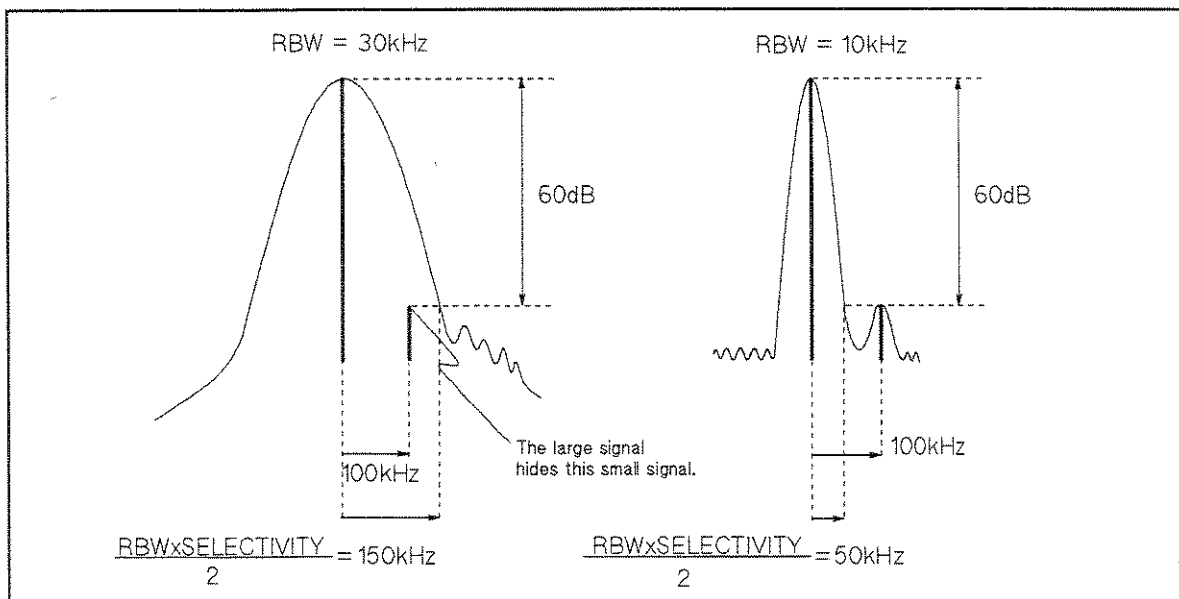

C5012025

Figure 12-12. Resolving Small Adjacent Signal

Because the analyzer uses a digital filter technique, the selectivity of the analyzer is better (smaller) than a conventional spectrum analyzer (which uses analog filter technique). This means the analyzer can detect a small signal that cannot be detected by a conventional spectrum analyzer. Especially in the stepped FFT mode ($RBW \leq 3$ kHz), the selectivity of the analyzer is less than one third of one at the swept mode ($RBW \geq 10$ kHz).

Noise measurement

Noise Format and Marker Noise Form

When a spectrum analyzer measures noise, the power shown by an analyzer is in proportion to RBW (because spectrum analyzers measure total power coming thorough RBW). For noise measurement, the measurement value is usually normalized by an equivalent noise bandwidth of an RBW filter (frequency). The noise format automatically normalizes noise power by the equivalent noise bandwidth and displays the trace on the screen. The marker noise form also reads out the noise level normalized, even if the format is the spectrum.

Sample Detection Mode for Noise Measurement

For noise measurement, the sample detection mode is best. Because the power of noise is uniformly distributed over frequency, it is not necessary to measure all the frequencies between the display points. It is sufficient to measure only the display points.

Reference Level Calibration

Spectrum measurement level calibration is an accuracy enhancement procedure that reduces the system error caused by uncertainty when switching the analyzer and temperature drift. It reduces the error by measuring a known calibrator's signal (the analyzer uses a -20 dBm, 20 MHz signal).

Spectrum measurement level accuracy is decided by the following error items

- Calibrator signal level accuracy
- Frequency response
- Amplitude fidelity
- IF gain switching uncertainty
- Input attenuator switching uncertainty
- RBW switching uncertainty
- Temperature drift

When level calibration is performed (and reference level, input attenuator, RBW, and temperature are not changed), the three switching uncertainties and temperature drift are removed. The error factors are then only the calibrator signal level accuracy, frequency response, and scale fidelity. For specifications or typical values of these error factors, see Chapter 10.

Spectrum Monitor at inputs R, A, and B

Input S is usually used for the spectrum measurement. However, the analyzer can also select input A, B, or R for spectrum monitoring. Note that because inputs R, A, and B are provided for network measurements, the input attenuators of these inputs are fixed.

The spectrum monitor at inputs A, B, and R can be used to observe the input signal during network measurement. See the *User's Guide* for a typical application measurement using the spectrum monitor.

Measurement Points and Display Points

In a network measurement, the analyzer measures at only the display points specified by NOP. In a spectrum measurement, the analyzer measures all the frequencies between the display points (except for sampling detection mode). This is done so that the analyzer can detect spectrums existing between the display points

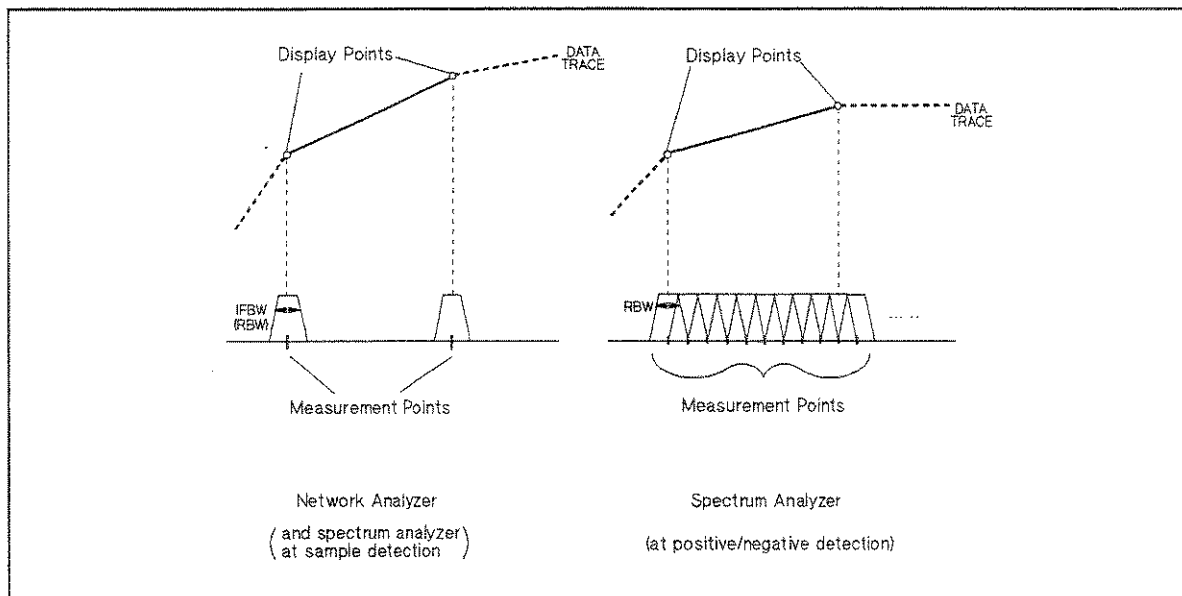

CS012039

Figure 12-13. Measurement Points and Display Points

Channel Coupling

When the analyzer type of both channels is the network analyzer mode, the sweep parameters can be coupled. But, when one channel measures a ratio measurement and the other one measures an absolute measurement (for example A/R and B), sweep parameters can not be coupled.

In the sweep parameter coupled mode, the following parameters are coupled:

- Frequency
- Number of points
- Source power level
- Number of groups
- IF bandwidth
- Sweep time
- Trigger type
- Sweep type

If both channels also have the same input parameter (such as S_{11} or A/R), the following parameters are coupled:

- Correction mode
- Calibration coefficient

The following parameters are always common to both channels when the analyzer types of both channels are the same (even if the sweep parameter mode is not coupled):

- Trigger source
- List sweep table
- Calibration kit type and data

The following parameters are always set separately for each channel (even if the sweep parameter mode is coupled):

- Measurement parameter
- Display Format
- Title
- Traces displayed
- Scale value
- Electrical delay
- Phase offset
- Averaging (on/off, factor)

Coupling of sweep parameter values for the two channels is independent of **DUAL CHAN on OFF** in the display menu and **MARKERS: UNCOUPLED** in the marker mode menu. **COUPLED CH OFF** becomes an alternate sweep function when dual channel display is on. In this mode, the analyzer alternates between the two sets of sweep parameter values for measurement of data and both are displayed.

Limit Line Concept

These are lines drawn on the display to represent upper and lower limits or device specifications with which to compare the DUT. Limits are defined by specifying several segments, where each segment is a portion of the sweep parameter span. Each limit segment has an upper and a lower starting limit value.

Limits can be defined independently for the two channels with up to 18 segments for each channel (a total of 36 for both channels). These can be in any combination of the two limit types.

Limit testing compares the measured data with the defined limits, and provides pass or fail information for each measured data point. An out-of-limit test condition is indicated in the following ways:

- Displaying a FAIL message on the screen
- Emitting a beep
- Displaying an asterisk in tabular listings of data
- Writing a bit into HP-IB event status register B

Limits are entered in tabular form. Limit lines and limit testing can be either ON or OFF while limits are defined. As new limits are entered, the tabular columns on the display are updated, and the limit lines (if on) are modified to the new definitions. The complete limit set can be offset in either sweep parameter or amplitude value.

How Limit Lines are Entered

Before limit lines can be explained, the concept of “segments” must be understood. A segment is the node of two limit lines. See Figure 12-14.

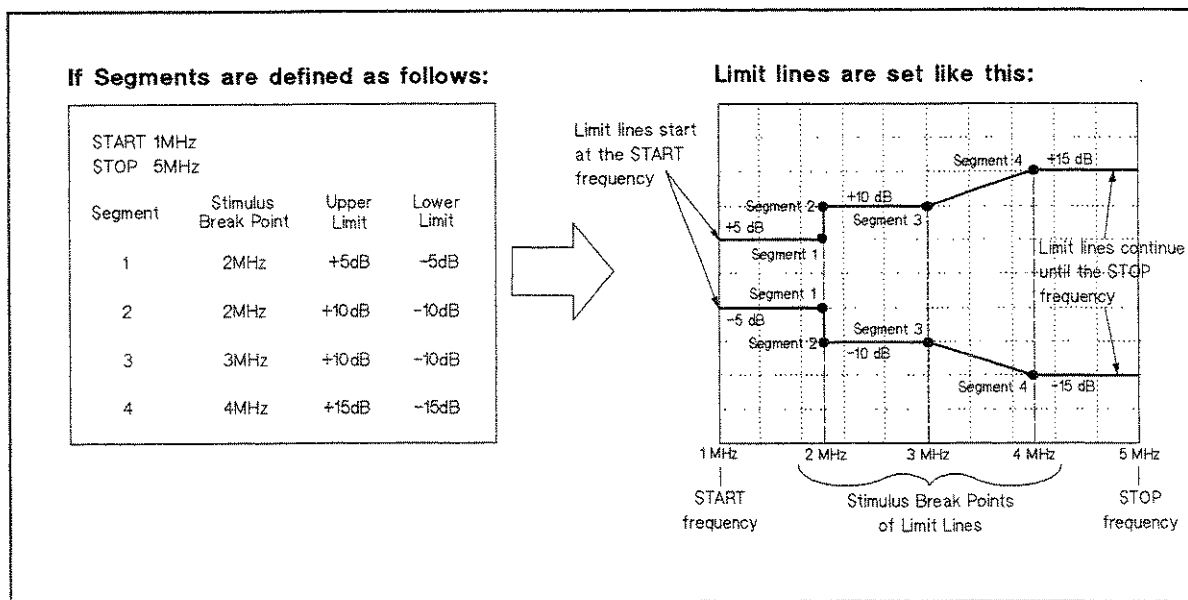

C5012042

Figure 12-14. The Concept of Segments as a Point between Two Sets of Limit Lines

As you can see in Figure 12-14, segments are distinct points that define where limit lines begin or end. Limit lines span the distance between segments and represent the upper and lower test limits. Figure 12-14 shows another important aspect of limit lines. The far left hand side of a set of limit lines will continue from the minimum sweep parameter value (START) and the far

right hand side of a set of limit lines will continue until the maximum sweep parameter value (STOP).

A segment is placed at a specific sweep parameter value (a single frequency for example). The first segment defines the limit line value from the minimum sweep parameter value. Once its sweep parameter value is entered, the upper and lower test limit (+5 dB and -5 dB for example) need to be supplied.

Defining a second segment defines where the first set of limit lines ends. This process is repeated to create different sets of limit lines, each having new upper and lower limits. Up to 18 segments can be entered.

Limits can be defined independently for the two channels.

The example in Figure 12-14 shows a combination of limit lines that change instantly and gradually.

Segment 1 is at 2 MHz and has an upper and lower limit of +5 and -5 dB, respectively. Notice the upper and lower limit lines start at the START frequency (1 MHz) and end at segment 1.

Segment 2 is also at 2 MHz with different upper and lower limits of +10 dB and -10 dB, changing the limit values instantly.

Segment 3 is at 3 MHz with the same limit value as segment 2 to obtain a flat limit lines.

Segment 4 is at 4 MHz with upper and lower limit values of +15 dB and -15 dB, changing the limit values gradually. Notice the upper and lower limit lines start at the segment and continue until the STOP frequency (5 MHz).

Note

Limit lines cannot be cut. Therefore, when limit lines are needed partially along the sweep parameter axis, the non-limit-testing portion must also be entered. Set the non-limit-testing portion by forcing the upper and lower limit values out of range (+500 dB and -500 dB for example).

Both an upper limit and a lower limit (or delta limits) must be defined. If only one limit is required for a particular measurement, force the other limit out of range (+500 dB or -500 dB for example).

Turning Limit Lines Limit Testing On and Off

Limit lines and limit testing features are OFF unless explicitly turned ON by the user. After entering the limit line information, you can turn ON the limit line feature and optionally the limit testing features. Turning these features OFF has no effect on the entered limit line information.

Segments Entering Order Needs Notice

Generally, the segments do not have to be entered in any particular order. The analyzer automatically sorts them and lists them on the display in increasing order of sweep parameter value.

One exception is when two segments have the same sweep parameter value as described in Figure 12-14. If the same sweep parameter values exist, the analyzer draws the limit lines according to entered segment order. For example, in Figure 12-14, segment 1 should be entered in advance of segment 2.

Saving the Limit Line Table

Limit line information is lost if the LINE switch is turned off. However, the **Save** and **Recall** keys can save limit line information along with all other current analyzer settings. Limit line table information can be saved on a disk.

Offsetting the Sweep Parameter or Amplitude of the Limit Lines

All limit line entries can be offset in either sweep parameter or amplitude values. The offset affects all segments simultaneously.

Supported Display Formats

Limit lines are displayed only in Cartesian format. In polar and Smith chart formats, limit testing of one value is available. The value tested depends on the marker mode and is the magnitude or the first value in a complex pair. The message "NO LIMIT LINES DISPLAYED" is shown on the display in polar and Smith formats.

Use a Sufficient Number of Points or Errors May Occur

Limits are checked only at the actual measured data points. If you do not select a sufficient number of points, it is possible for a device to be out of specification without a limit test failure indication.

To avoid this, be sure to specify a high enough number of points. In addition, if specific sweep parameter points must be checked, use the list sweep features described in "**Sweep**" in Chapter 6 so that the actual measured data points are checked.

Displaying, Printing, or Plotting Limit Test Data

The "list values" feature in the copy menu prints or displays a table of each measured sweep parameter value. The table includes limit line and limit test information (if these functions are turned on). If limit testing is ON, an asterisk "*" is listed next to any measured value that is out of limits.

If the limit lines are ON, and other listed data allows sufficient space, the following information is also displayed:

- Upper limit and lower limit
- The margin by which the device passes or fails the nearest limit

For more information about the list values feature, see "Copy Menu

Network Analyzer
Spectrum Analyzer" in Chapter 8.

Results of Plotting or Printing the Display with Limit Lines ON

If limit lines are on, they are shown when you print or plot the display. If limit testing is ON, the PASS or FAIL message is included as well.

Note



An example of a measurement using limit lines and limit testing is provided in the *User's Guide*.

A sample program performing a limit test using HP-IB commands is provided in the *HP-IB Programming Guide*.

Gated Sweep

The gated sweep function can be used to measure any one of several signals separated in time (for example, burst modulated, pulsed RF, and time multiplexed). Using the gated sweep function allows the analyzer to measure the spectrum of a specific part of the signal or separate signals, and mask out interfering or transient signals. In the gated sweep mode, the analyzer is triggered to start and interrupt sweep selectively by an external trigger signal. By controlling the external trigger signal, the analyzer measures only the signals that are present when the analyzer sweeps.

The gate sweep is controlled by the following factors:

- Trigger polarity, which determines which positive or negative edge (level) causes triggering
- Gate trigger mode, which selects one of two modes (EDGE or LEVEL)
- Gate Delay, which determines how long after the trigger signal the gate actuarially becomes active.
- Gate Length, which determines how long the gate is on.

Trigger Polarity

The analyzer can select the external trigger polarity (positive and negative). When POSITIVE is selected, the analyzer starts the sweep when the external trigger signal is a positive edge or level.

Gate Trigger Mode

Two gate trigger modes (EDGE and LEVEL) are provided for the gate trigger to match the trigger signal used.

Edge Mode

The edge mode allows you to position the gate relative to either the rising or falling edge of a TTL trigger signal. The edge initiates the gate delay. For the edge mode, the gate sweep is controlled by the following factors:

- Trigger polarity, which selects the edge (positive or negative) to initiate the start point of the gate sweep. At the start point, the edge initiates the gate delay.
- Gate Delay, which determines how long after the trigger signal the gate actuarially becomes active.
- Gate Length, which determines how long the gate is on.

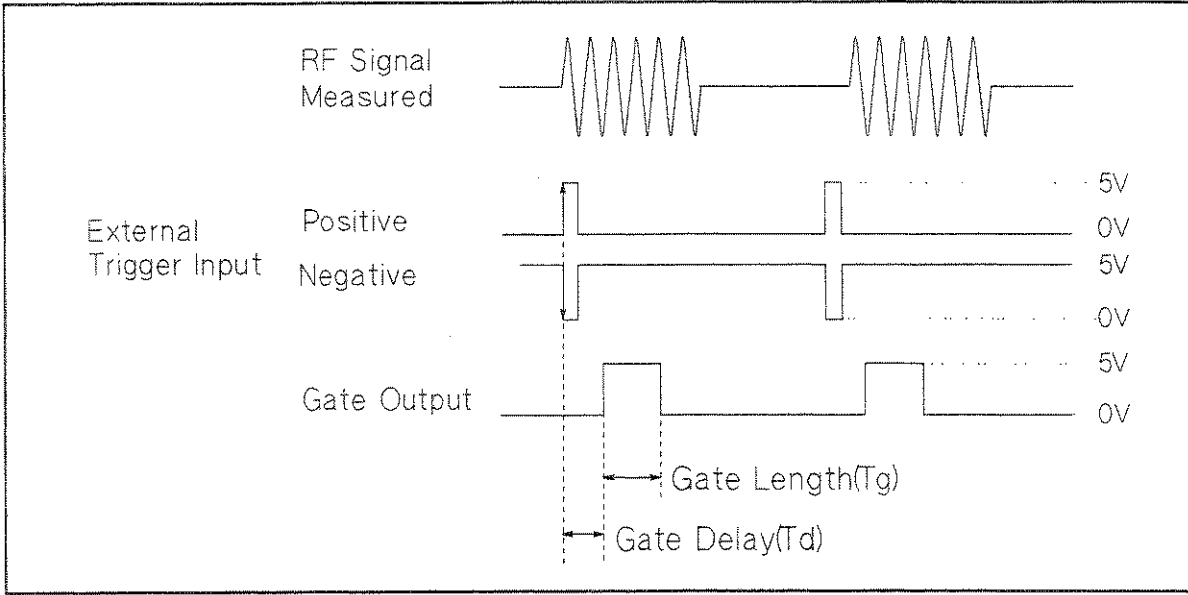

C6012026

Figure 12-15. Edge Mode

Level Mode

The level mode allows the external trigger signal to open and close the gate directly, without a programmed gate length. The level mode also provides the gate delay. For the level mode, the gate sweep is controlled by the following factors:

- Trigger polarity, which selects the polarity of TTL the level (+5 or 0) to open gate.
- Gate Delay, which determines how long after the trigger signal the gate becomes active.

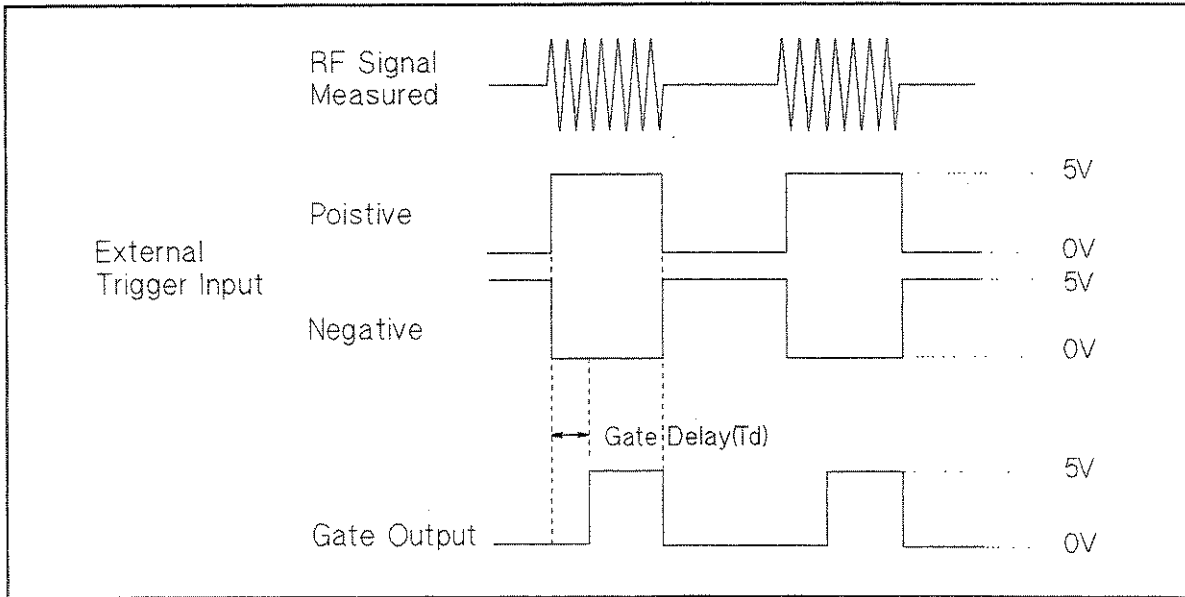

C6012027

Figure 12-16. Level Mode

RBW Filter Response Time

The resolution bandwidth filter requires the set-up time to fully charge before the gate comes on. Set-up time is the length of time that the signal is present and stable before the gate comes on. The set-up time should be greater than filter charge time (which is defined by $2/\text{RBW}$, where RBW is the -3 dB resolution bandwidth being used).

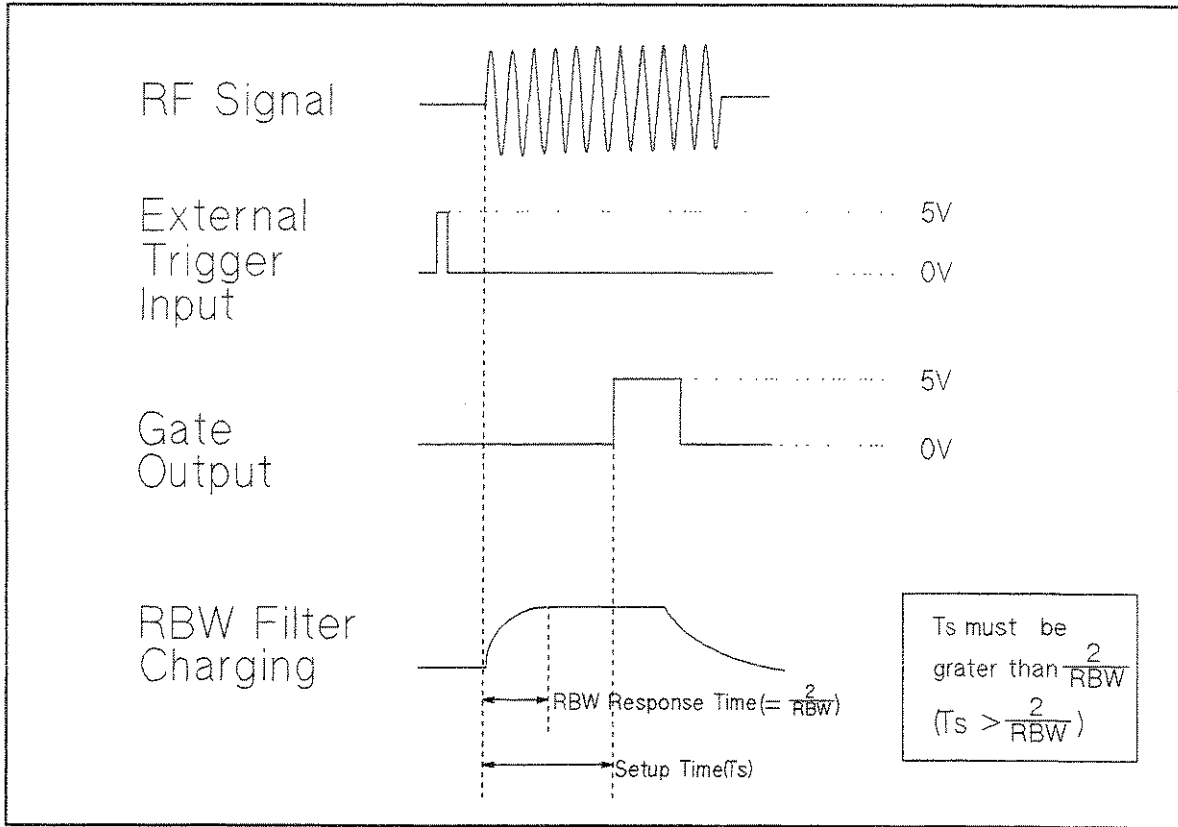

Figure 12-17. RBW Filter Response Time

Video bandwidth (VBW) can be set without concern for the gate length setting. The analyzer implements the video filter using digital processing. The video filter of the analyzer requires no settling time for normal operation. Therefore, it is not affected by the gate length setting.

Gated Sweep on the Stepped FFT

When RBW is less than or equal to 3 kHz, the analyzer uses stepped FFT mode. Because stepped FFT mode requires sampling time to get data, the gate length should be more than the minimum sampling time. The sampling time depends on the RBW being used as follows:

Table 12-1. Minimum Gate Length on the Stepped FFT mode

RBW [Hz]	Min. Gate Length [sec]
1	5.185625
3	1.6594
10	518.5625 m
30	134.5625 m
100	51.2 m
300	12.8 m
1 k	3.2 m
3 k	1.6 m

Repetitive Sampling

The analyzer provides a normal sampling mode and a repetitive sampling mode for zero span. The normal sampling mode samples the signal at a $25 \mu\text{s}$ sampling rate. The repetitive sampling mode can measure faster signals because the sampling rate of the repetitive mode is $0.5 \mu\text{s}$. Because the repetitive sampling mode needs an interval time ($\geq 25 \mu\text{s}$) after every sampling, the signal being measured must be a repetitive signal. Also, it takes a longer time to sweep than the sweep time displayed. (See Figure 12-18.)

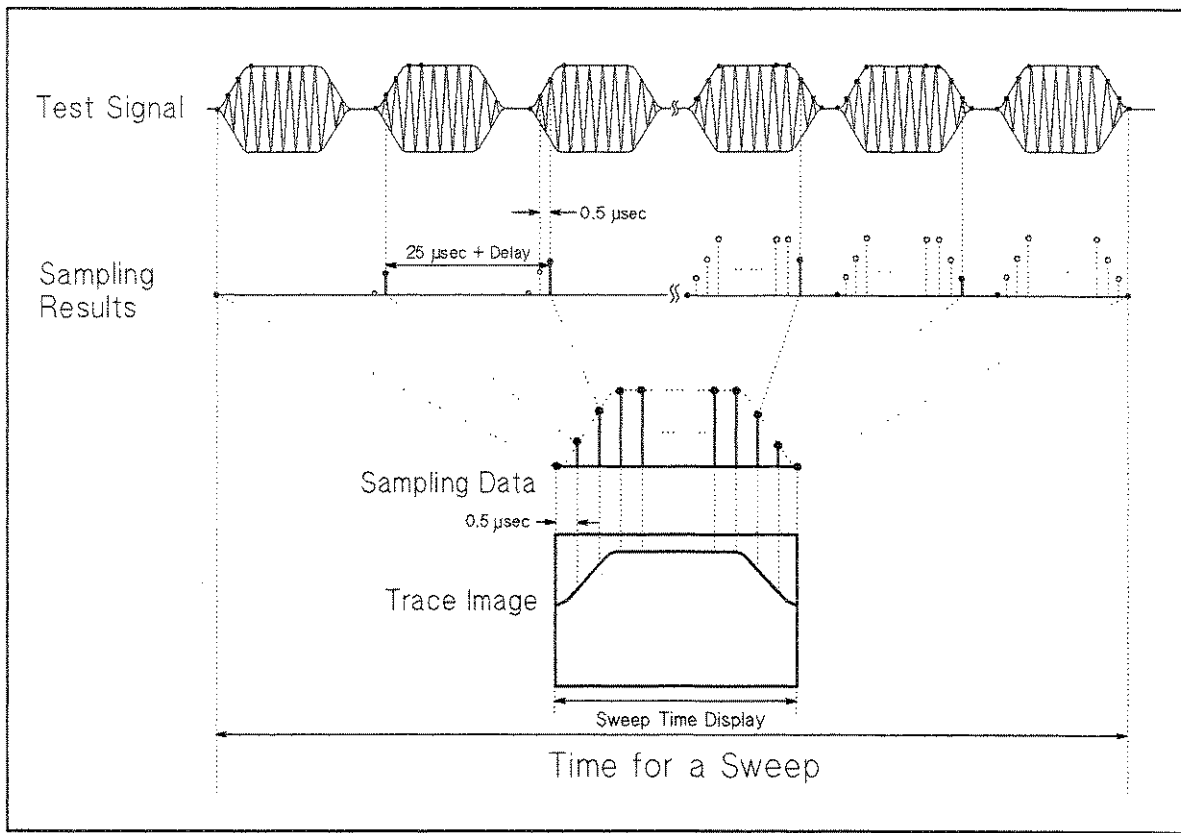

Figure 12-18. Repetitive Sampling

Markers

Three Types of Markers

Three types of markers are provided for each channel. The first is the movable marker that is displayed on the screen (as ∇) when **Marker**, **Marker→**, **Search**, or **Utility** is pressed. When a marker is turned on and no other function is active, the marker can be controlled with the knob, or the step keys. The second is the sub-markers that appear at the present marker position when a softkey in the sub-marker menu is pressed. The seven sub-markers can be displayed for each channel at same time (a total of 14). The third is the Δ marker that defines a reference position of the delta mode. There three Δ mode, Δ marker(normal), tracking Δ marker, and fixed Δ marker.

Marker Value

Markers have a sweep parameter value (the x-axis value in a Cartesian format) and a measurement value (the y-axis value in a Cartesian format). In a polar, Smith, or admittance chart format, the second part of a complex data pair is also provided as an auxiliary measurement value.

The marker can be moved to any point on the trace, Its measurement and sweep parameter values are displayed at the top right corner of the graticule for each displayed channel (in units appropriate to the display format). The displayed marker measurement values are valid even when the measured data is above or below the range displayed on the graticule. When marker list is turned on, sweep parameter values and measurement values of all markers are listed on the graticule. In a polar, Smith, or admittance chart format, auxiliary measurement values of all markers are also listed.

Marker Time Mode

When marker time mode is turned on, the x-axis is changed to the time scale. The start point of the x-axis is 0 seconds and the stop point indicates the sweep time. The markers have a time instead of a sweep parameter value.

Continuous/Discrete Mode

Marker values of the network analyzer are normally continuous (that is, they are interpolated between measured points). Alternatively, they can be set to read only discrete measured points. The marker of the spectrum analyzer always reads only the discrete measured point.

Marker on the Data Trace or on the Memory Trace

If both data and memory are displayed, you can select which marker values apply to the data trace or the memory trace. If data or memory is displayed (not both), the marker values apply to the trace displayed. In a data math display (data+memory, data-memory, or data/memory), the marker values apply to the trace resulting from the memory math function.

ΔMode

With the use of a delta marker, a delta marker mode is available that displays both the sweep parameter and measurement values of the marker relative to the reference. Any position on the trace or a fixed point can be designated as the delta marker. The Δmarker can be put on a current position of the marker. If the delta reference is the fixed Δmarker, both its sweep parameter value and its magnitude value (y-axis value) can be set arbitrarily anywhere in the display area (not necessarily on the trace). If the delta marker is the tracking Δmarker, its sweep parameter value can be controlled and its measurement value is the value of the trace at that sweep parameter value.

Marker Search Function

Markers can search for the trace maximum/minimum, mean point, any other point, peak maximum/minimum or peak-to-peak value of all or part of the trace. The marker and sub-markers can be used together to search for specified bandwidth cutoff points and calculate the bandwidth. Statistical analysis uses markers to provide a readout of the mean, standard deviation, and peak-to-peak values of all or part of the trace.

Width Function

The bandwidth search feature analyzes a bandpass or band reject trace and calculates the center point, bandwidth, and Q (quality factor) for the specified bandwidth. These parameters depend on the Δmarker mode. The following table shows how each parameter is determined for each Δmarker mode.

Parameter	TrackingΔMarker	FixedΔMarker
BW	Displays the bandwidth value set by WIDTH VALUE .	
Center	Displays the center sweep parameter value between the cutoff points (this is marked by sub-marker 1).	
Q	Displays the Q value (= cent/BW) of the trace.	
Insertion Loss	Displays the absolute value of the marker.	Displays the difference between the marker and the fixed Δmarker.
ΔF (left)	Displays the sweep parameter value difference between marker 2 and the center frequency specified by the Center key.	Displays the sweep parameter value difference between marker 2 and the fixed Δmarker.
ΔF (right)	Displays the sweep parameter value difference between marker 3 and center frequency specified by the Center key.	Displays the sweep parameter value difference between marker 3 and the fixed Δmarker.

Figure 12-19 shows an example of the bandwidth search feature.

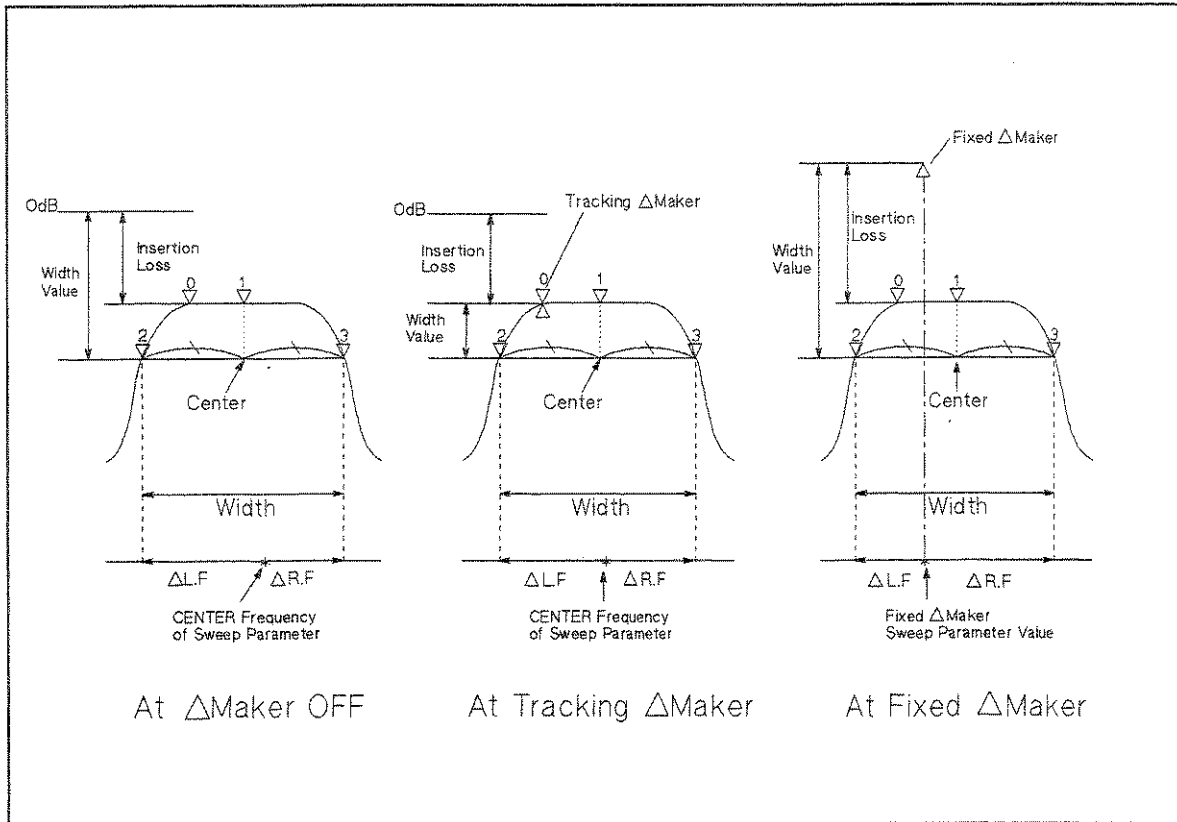

65012040

Figure 12-19. Bandwidth Search Example

Peak Definition

The search function provides the define peak feature, which specifies the properties of the peaks searched for by the peak search function. The define peak feature also allows the peak search function to discriminate peaks from noise.

The peak definitions are different for the network analyzer mode and the spectrum analyzer mode.

Peak Definition for Network Analyzer

The following parameters are used in the peak definition for the network measurement:

- Peak polarity (positive or negative)
- ΔX , ΔY (gradient)
- Threshold value

The search functions search for a peak where the parameters of the peak match the following conditions:

$$\frac{\Delta Y}{\Delta X} \times SPAN \leq \min(\Delta y_L, \Delta y_R)$$

and

$$Threshold \leq Peak \text{ Amplitude Value}$$

Where,

Δy_L , Δy_R are the difference in amplitude value between a peak and the adjacent measurement points on both sides.

That is, the search functions search for a peak where, the gradient is greater than $\Delta Y/\Delta X$, and the amplitude is greater than the threshold value. The search functions ignore a peak when the amplitude value is less than the threshold even if the peak polarity is set to negative.

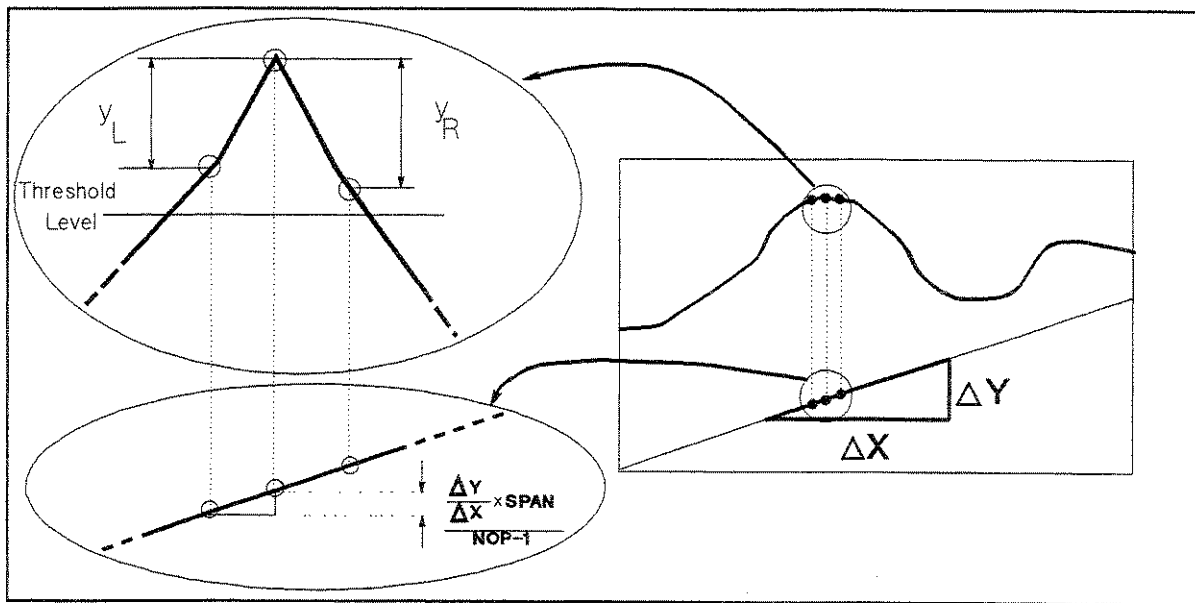

Figure 12-20. Peak Definition for Network Analyzer

Peak Definition for Spectrum Analyzer

The following parameters are used in the peak definition for the spectrum measurement:

- ΔY (difference of amplitude between a peak and an adjacent local minimum point)
- Threshold value

The search functions search for a peak where the parameters of the peak match the following conditions:

$$\Delta Y \leq \min(\max(\Delta y_L, \Delta y_R), \Delta y_{TH})$$

Where,

$\Delta y_L, \Delta y_R$ are the difference in amplitude value between a peak and the adjacent local minimum point.

Δy_{TH} is the difference between a peak and the threshold value.

That is, the search functions search for a peak where the difference of amplitude between the peak and the smaller of the adjacent local minimum points is greater than ΔY , and the difference between the peak and the threshold is greater than ΔY .

The peak polarity is always positive for the spectrum analyzer peak search functions.

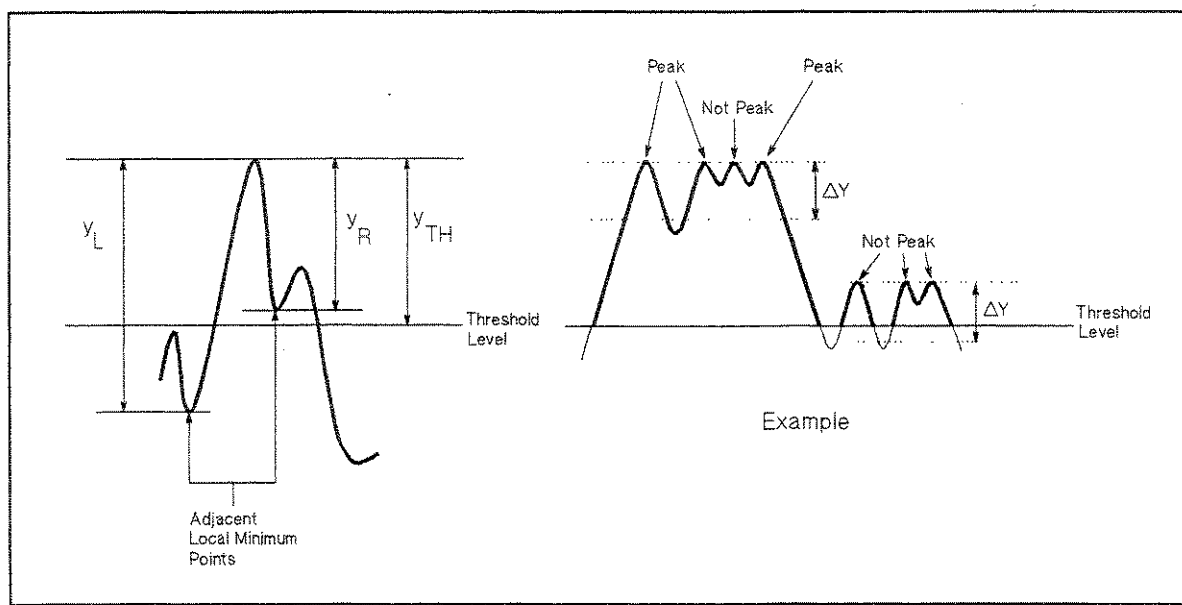

C6012045

Figure 12-21. Peak Definition for Spectrum Analyzer

HP-IB

The analyzer is factory-equipped with a remote programming digital interface using the Hewlett-Packard Interface Bus (HP-IB). (HP-IB is Hewlett-Packard's hardware, software, documentation, and support for IEEE 488.1, IEC-625, IEEE 488.2, and JIS-C1901 worldwide standards for interfacing instruments.) This allows the analyzer to be controlled by an external computer that sends commands or instructions to and receives data from the analyzer using the HP-IB. In this way, a remote operator has the same control of the instrument available to a local operator from the front panel, except for the line power switch.

In addition, the analyzer itself can use HP-IB to directly control compatible peripherals, without the use of an external controller. It can output measurement results directly to a compatible printer or plotter.

This section provides an overview of HP-IB operation. The *HP 4396B Task Reference* provides information on setting up the analyzer as a controller of peripherals. It also explains how to use the analyzer as a controller to print and plot. HP-IB equivalent mnemonics for front panel functions are provided in parentheses throughout this manual.

More complete information on programming the analyzer remotely over HP-IB is provided in *HP-IB Programming Guide*. The *HP-IB Programming Guide* includes examples of remote measurements using an HP 9000 series 200 or 300 computer with BASIC programming. The *HP-IB Programming Guide* assumes familiarity with front panel operation of the instrument.

A complete general description of the HP-IB is available in *Tutorial Description of the Hewlett-Packard Interface Bus*, HP publication 5952-0156. For more information on the IEEE 488.1 standard, see *IEEE Standard Digital Interface for Programmable Instrumentation*, published by the Institute of Electrical and Electronics Engineers, Inc., 345 East 47th Street, New York 10017, USA.

How HP-IB Works

The HP-IB uses a party-line bus structure in which up to 15 devices can be connected on one contiguous bus. The interface consists of 16 signal lines and 6 grounded lines in a shielded cable. With this cabling system, many different types of devices including instruments, computers, plotters and printers can be connected in parallel.

Every HP-IB device must be capable of performing one or more of the following interface functions:

Talker

A talker is a device capable of sending device-dependent data when addressed to talk. There can be only one active talker at any given time. Examples of this type of device are voltmeters, counters, and tape readers. The analyzer is a talker when it sends trace data or marker information over the bus.

Listener

A listener is a device capable of receiving device-dependent data when addressed to listen. There can be any number of active listeners at any given time. Examples of this type of device are printers, power supplies, and signal generators. The analyzer is a listener when it is controlled over the bus by a computer.

Controller

A controller is a device capable of managing the operation of the bus and addressing talkers and listeners. There can be only one active controller at any time. Examples of controllers include desktop computers and minicomputers. In a multiple-controller system, active control can be passed between controllers, but there can only be one *system controller* that acts as the master, and can regain active control at any time. The analyzer is an active controller when it plots or prints in the addressable mode. The analyzer is a system controller when it is in the system controller mode.

HP-IB Requirements

Number of Interconnected Devices:	15 maximum.
Interconnection Path/ Maximum Cable Length:	20 meters maximum or 2 meters per device, whichever is less.
Message Transfer Scheme:	Byte serial/bit parallel asynchronous data transfer using a 3-line handshake system.
Data Rate:	Maximum of 1 megabyte per second over limited distances with tri-state drivers. Actual data rate depends on the transfer rate of the slowest device involved.
Address Capability:	Primary addresses: 31 talk, 31 listen. A maximum of 1 active talker and 14 active listeners at one time.
Multiple Controller Capability:	In systems with more than one controller (like the analyzer system), only one can be active at any given time. The active controller can pass control to another controller, but only one system controller is allowed.

Analyzer HP-IB Capabilities

As defined by the IEEE 488.1 standard, the analyzer has the following capabilities:

SH1	Full source handshake.
AH1	Full acceptor handshake.
T6	Basic talker, answers serial poll, unaddresses if MLA is issued. No talk-only mode.
TE0	Does not have extended address of talker.
L4	Basic listener, unaddresses if MTA is issued. No listen-only mode.
LE0	Does not have extended address of listener.
SR1	Complete service request (SRQ) capabilities.
RL1	Complete remote/local capability including local lockout.
PP0	Does not respond to parallel poll.
DC1	Complete device clear.
DT1	Responds to a group execute trigger.
C1, C2, C3, C4	System controller capabilities in system controller mode.
C11	Pass control capabilities in addressable mode.
E2	Tri-state drivers.

Bus Mode

The analyzer uses a single-bus architecture. The single bus allows both the analyzer and the host controller to have complete access to the peripherals in the system.

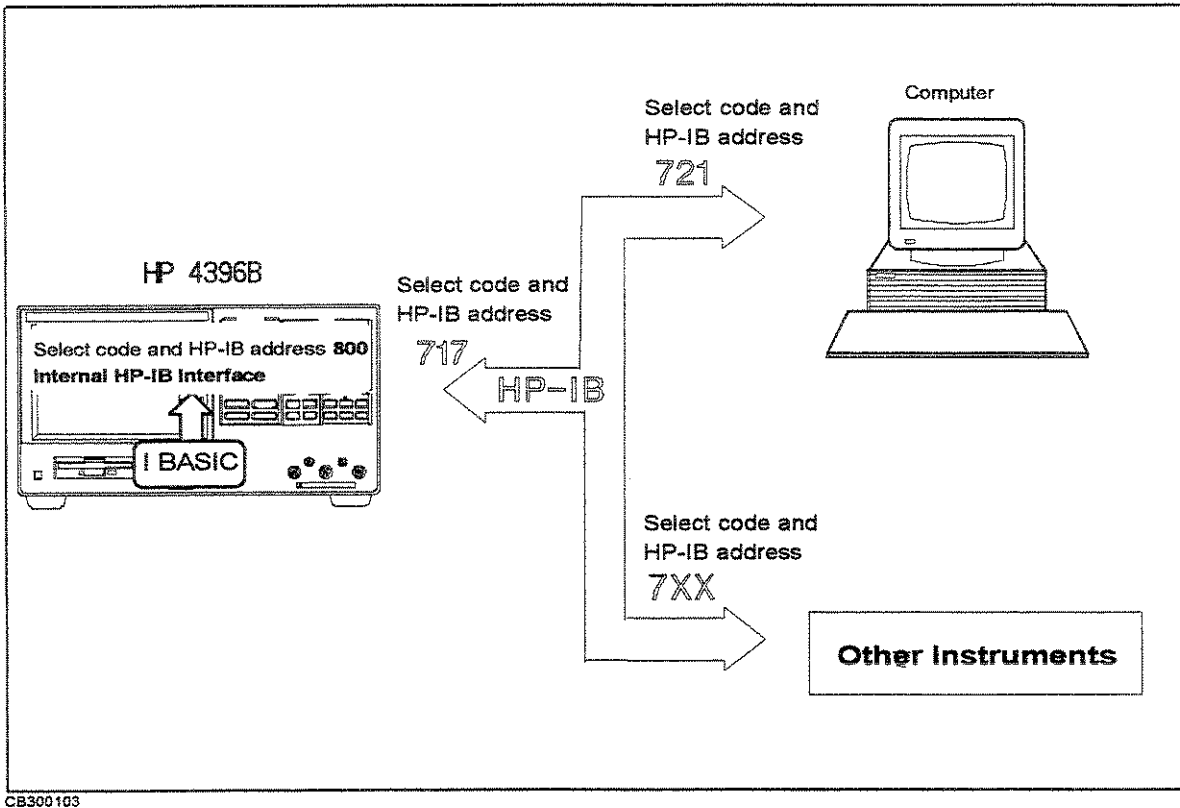

Figure 12-22. Analyzer Single Bus Concept

Two different modes are possible, system controller and addressable.

- | | |
|-------------------|--|
| System Controller | This mode allows the analyzer to control peripherals directly in a stand-alone environment (without an external controller). This mode can only be selected manually from the analyzer front panel. Use this mode for operation when no computer is connected to the analyzer. Printing and plotting use this mode. |
| Addressable | This is the traditional programming mode, in which the computer is involved in all peripheral access operations. When the external controller is connected to the analyzer through HP-IB (as shown in Figure 12-22), this mode allows you to control the analyzer over HP-IB in the talker mode in order to send data, and in the listener mode to receive commands. It also allows the analyzer to take or pass control in order to plot and print. |

The *HP 4396B Task Reference* provides information on setting the correct bus mode. Programming information for the addressable mode is provided in the *HP-IB Programming Guide*.

Setting Addresses

In HP-IB communications, each instrument on the bus is identified by an HP-IB address. This address code must be different for each instrument on the bus. See Appendix D for information on default addresses, and on setting and changing addresses. These addresses are not affected when you press **Preset** or cycle the power.

Calibration for Network Measurement

Introduction

Network measurement calibration is an accuracy enhancement procedure that effectively reduces the system errors that cause uncertainty in measuring a DUT. It measures known standard devices, and uses the results of these measurements to characterize the system.

This section explains the theoretical fundamentals of accuracy enhancement and the sources of measurement errors. It describes the different measurement calibration procedures available in the analyzer, which errors they correct, and the measurements for which each should be used. The later part of this section provides further information on characterizing systematic errors and using error models to analyze the overall measurement performance.

Accuracy Enhancement

If it were possible for a perfect measurement system to exist, it would have infinite dynamic range, isolation, and directivity characteristics, no impedance mismatches in any part of the test setup, and flat frequency response. Vector accuracy enhancement, also known as measurement calibration or error correction, provides the means to simulate a perfect measurement system.

In any high frequency measurement, there are measurement errors associated with the system that contribute uncertainty to the results. Parts of the measurement setup such as interconnecting cables and signal separation devices (as well as the analyzer itself) all introduce variations in magnitude and phase that can mask the actual performance of the DUT.

For example, crosstalk due to the channel isolation characteristics of the analyzer can contribute an error equal to the transmission signal of a high-loss test device. For reflection measurements, the primary limitation of dynamic range is the directivity of the test setup. The measurement system cannot distinguish the true value of the signal reflected by the DUT from the signal arriving at the receiver input due to leakage in the system. For both transmission and reflection measurements, impedance mismatches within the test setup cause measurement uncertainties that appear as ripples superimposed on the measured data.

Measurement calibration simulates a perfect analyzer system. It measures the magnitude and phase responses of known standard devices, and compares the measurement with actual device data. It uses the results to characterize the system and effectively remove the system errors from the measurement data of a test device, using vector math capabilities internal to the analyzer.

When measurement calibration is used, the dynamic range and accuracy of the measurement are limited only by system noise and stability, connector repeatability, and the accuracy to which the characteristics of the calibration standards are known.

Sources of Measurement Errors

Network analysis measurement errors can be separated into systematic, random, and drift errors.

Correctable systematic errors are the repeatable errors that the system can measure. These are errors due to mismatch and leakage in the test setup, isolation between the reference and test signal paths, and system frequency response.

The system cannot measure and correct for the non-repeatable random and drift errors. These errors affect both reflection and transmission measurements. Random errors are measurement variations due to noise and connector repeatability. Drift errors include frequency drift, temperature drift, and other physical changes in the test setup between calibration and measurement.

The resulting measurement is the vector sum of the DUT response plus all error terms. The precise effect of each error term depends upon its magnitude and phase relationship to the actual test device response.

In most high frequency measurements the systematic errors are the most significant source of measurement uncertainty. Because each of these errors can be characterized, their effects can be effectively removed to obtain a corrected value for the test device response. For the purpose of vector accuracy enhancement these uncertainties are quantified as directivity, source match, load match, isolation (crosstalk), and frequency response (tracking). Each of these systematic errors is described below.

Random and drift errors cannot be precisely quantified, so they must be treated as producing a cumulative uncertainty in the measured data.

Directivity

Normally a device that can separate the reverse from the forward traveling waves (a directional bridge or coupler) detects the signal reflected from the DUT. Ideally the coupler would completely separate the incident and reflected signals, and only the reflected signal would appear at the coupled output (Figure 12-23-a).

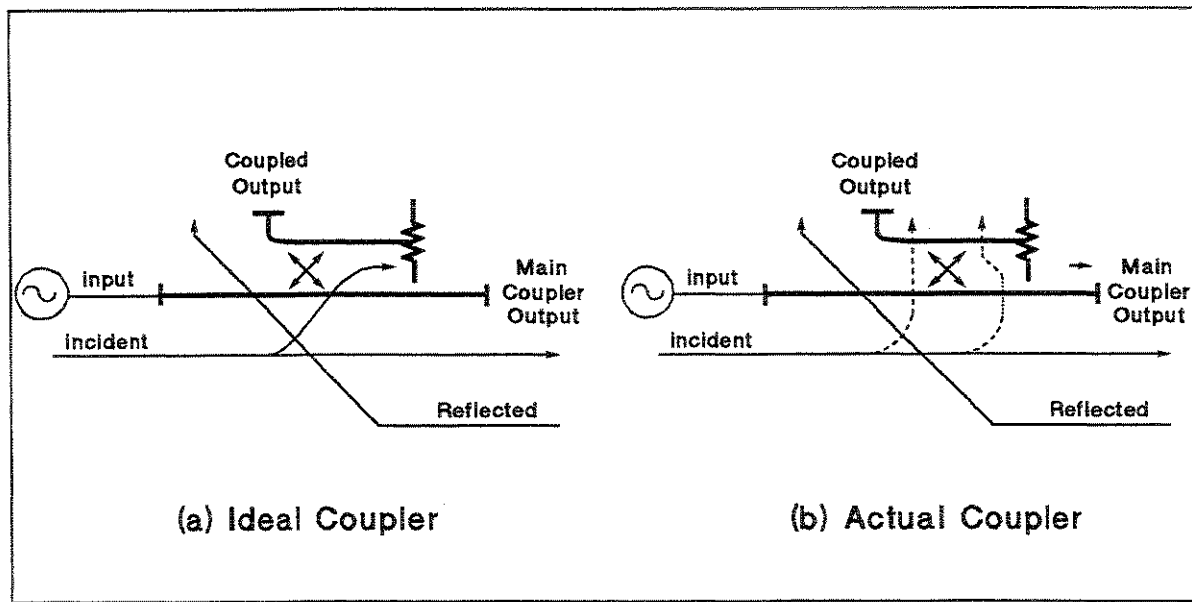

CS012036

Figure 12-23. Directivity

However, an actual coupler is not perfect (Figure 12-23-b). A small amount of the incident signal appears at the coupled output due to leakage as well as to reflection from the termination in the coupled arm. Also, reflections from the main coupler output connector appear at the coupled output, adding uncertainty to the signal reflected from the device. The figure of merit for how well a coupler separates forward and reverse waves is directivity. The greater the directivity of the device, the better the signal separation. Directivity is the vector sum of all leakage signals appearing at the analyzer receiver input due to the inability of the signal separation device to separate incident and reflected waves, and to residual reflection effects of test cables and adapters between the signal separation device and the measurement plane. The error contributed by directivity is independent of the characteristics of the test device and it usually produces the major ambiguity in measurements of low reflection devices.

Source Match

Source match is defined as the vector sum of signals appearing at the analyzer receiver input due to the impedance mismatch at the test device looking back into the source. Source match is degraded by adapters and extra cables. A non-perfect source match leads to mismatch uncertainties that affect both transmission and reflection measurements. Source match is most often given in terms of return loss in dB (therefore, the larger the number, the smaller the error).

- In a reflection measurement, the source match error signal is caused by some of the reflected signal from the DUT being reflected from the source back toward the DUT and re-reflected from the DUT (Figure 12-24).
- In a transmission measurement, the source match error signal is caused by reflection from the test device that is re-reflected from the source.

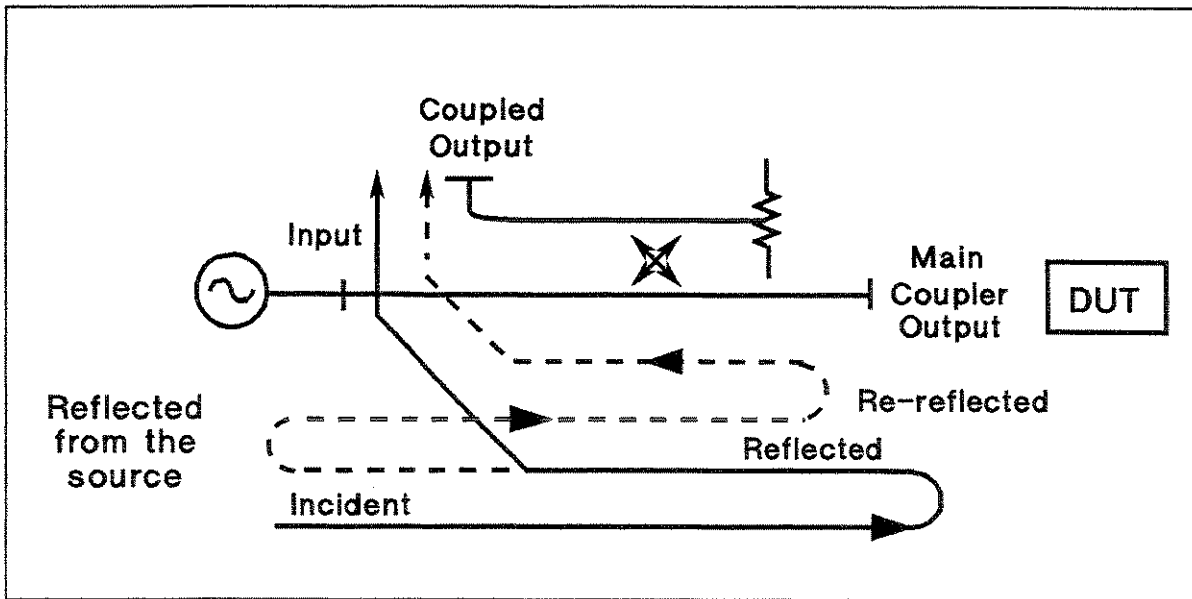

Figure 12-24. Source Match

The error contributed by source match is a mismatch error caused by the relationship between the actual input impedance of the test device and the equivalent match of the source. It is a factor in both transmission and reflection measurements. Mismatch uncertainty is particularly a problem in measurements where there is a large impedance mismatch at the measurement plane.

Load Match

Load match error results from an imperfect match at the output of the test device. It is caused by impedance mismatches between the test device output port and port 2 of the measurement system. As illustrated in Figure 12-25, some of the transmitted signal is reflected from port 2 back to the test device. A portion of this wave can be re-reflected to port 2, or part can be transmitted through the device in the reverse direction to appear at port 1. If the DUT has low insertion loss (for example a transmission line), the signal reflected from port 2 and re-reflected from the source causes a significant error because the DUT does not attenuate the signal significantly on each reflection. Load match is usually given in terms of return loss in dB (therefore, the larger the number, the smaller the error).

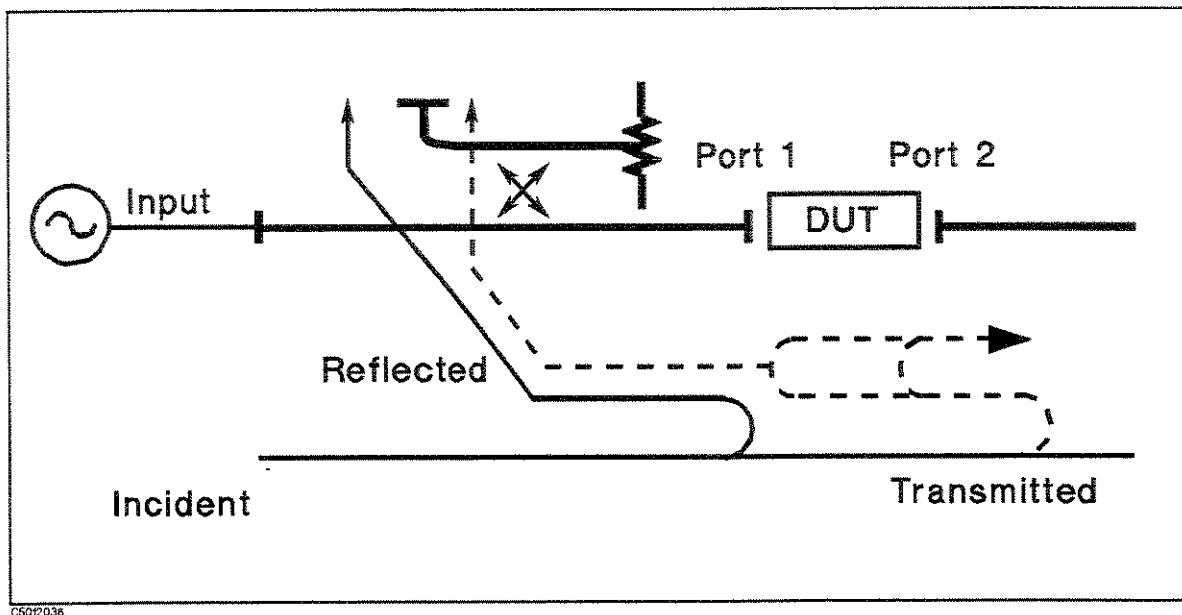

Figure 12-25. Load Match

The error contributed by load match depends on the relationship between the actual output impedance of the test device and the effective match of the return port (port 2). It is a factor in all transmission measurements and in reflection measurements of two-port devices. Load match and source match are usually ignored when the test device insertion loss is greater than about 6 dB. This happens because the error signal is greatly attenuated each time it passes through the DUT. However, load match effects produce major transmission measurement errors for a test device with a highly reflective output port.

Isolation (Crosstalk)

Leakage of energy between analyzer signal paths contributes to error in a transmission measurement much as directivity does in a reflection measurement. Isolation is the vector sum of signals appearing at the analyzer receivers due to crosstalk between the reference and test signal paths, including signal leakage within the test set and in both the RF and IF sections of the receiver.

The error contributed by isolation depends on the characteristics of the DUT. Isolation is a factor in high-loss transmission measurements. However, analyzer system isolation is more than sufficient for most measurements, and correction for it may be unnecessary. For measuring devices with high dynamic range, accuracy enhancement can provide improvements in isolation that are limited only by the noise floor.

Frequency Response (Tracking)

This is the vector sum of all test setup variations in which magnitude and phase change as a function of frequency. This includes variations contributed by signal separation devices, test cables, and adapters, and variations between the reference and test signal paths. This error is a factor in both transmission and reflection measurements.

For further explanation of systematic error terms and the way they are combined and represented graphically in error models, see the later section, titled Accuracy Enhancement Fundamentals - Characterizing Systematic Errors.

Correcting for Measurement Errors

There are twelve different error terms for a two-port measurement that can be corrected by accuracy enhancement in the analyzer. These are directivity, source match, load match, isolation, reflection tracking, and transmission tracking, each in both the forward and reverse direction. The analyzer has several different measurement calibration routines to characterize one or more of the systematic error terms and remove their effects from the measured data. The procedures range from a simple frequency response calibration to a full two-port calibration that effectively removes all twelve error terms.

The **Response Calibration** effectively reduces the frequency response errors of the test setup for reflection or transmission measurements. This calibration procedure may be adequate for measurement of well-matched low-loss devices. This is the simplest error correction to perform, and should be used when extreme measurement accuracy is not required.

The **Response and Isolation Calibration** effectively removes frequency response and crosstalk errors in transmission measurements, or frequency response and directivity errors in reflection measurements. This procedure may be adequate for measurement of well-matched high-loss devices.

The **S₁₁ and S₂₂ One-Port Calibration** procedures provide directivity, source match, and frequency response vector error correction for reflection measurements. These procedures provide high accuracy reflection measurements of one-port devices or properly terminated two-port devices.

The **Full Two-Port Calibration** provides directivity, source match, load match, isolation, and frequency response vector error correction, in both forward and reverse directions, for transmission and reflection measurements of two-port devices. This calibration provides the best magnitude and phase measurement accuracy for both transmission and reflection measurements of two-port devices, and requires an S-parameter test set.

The **One-Path Two-Port Calibration** provides directivity, source match, load match, isolation, and frequency response vector error correction in one direction. It is used for high accuracy transmission and reflection measurements using a transmission/reflection test kit, such as the HP 87512A, B. (The DUT must be manually reversed between sweeps to accomplish measurements in both the forward and reverse directions.)

All the calibration procedures described above are accessed from the **CAL** key and are described in the "**Cal**" in Chapter 5.

Modifying Calibration Kits

For most applications, use the default cal kit models provided in the select cal kit menu described in “Cal” in Chapter 5. Modifying calibration kits is necessary only if unusual standards are used or the very highest accuracy is required. Unless a cal kit model is provided with the calibration devices used, a solid understanding of error correction and the system error model are essential to making modifications. Read all of this section.

During measurement calibration, the analyzer measures actual, well-defined standards and mathematically compares the results with ideal “models” of those standards. The differences are separated into error terms which are later reduced during error correction. Most of the differences are due to systematic errors - repeatable errors introduced by the analyzer, test set, and cables - which are correctable. However, the difference between the standard’s mathematical *model* and its *actual performance* has an adverse affect; it reduces the system’s ability to remove systematic errors, and thus degrades error-corrected accuracy. Therefore, in addition to the default cal kit models, a “user kit” is provided that can be modified to an alternate calibration standards model.

Several situations exist that may require a user-defined cal kit:

- You use a connector interface different from the four built-in cal kits. (Examples: SMA, or BNC.)
- You are using standards (or combinations of standards) that are different from the predefined cal kits. (For example, using three offset SHORTs instead of an OPEN, SHORT, and LOAD to perform a 1-port calibration.)
- You want to improve the built-in standard models for predefined kits. Remember that the more closely the model describes the actual performance of the standard, the better the calibration. (Example: The 7 mm LOAD is determined to be 50.4 Ω instead of 50.0 Ω .)
- Unused standards for a given cal type can be eliminated from the default set, to eliminate possible confusion during calibration. (Example: A certain application requires calibrating a male test port. The standards used to calibrate a female test port can be eliminated from the set, and will not be displayed during calibration.)

Definitions

The following are definitions of terms:

- A **standard** is a specific, well-defined, physical device used to determine systematic errors.
- A **standard type** is one of five basic types that define the form or structure of the model to be used with that standard (for example, a SHORT or a LOAD).
- **Standard coefficients** are numerical characteristics of the standards used in the model selected.
- A **standard class** is a grouping of one or more standards that determines which standards are used in a particular calibration procedure.

Define Standard

Standard definition is the process of mathematically modeling the electrical characteristics (delay, attenuation, and impedance) of each calibration standard. These electrical characteristics (coefficients) can be mathematically derived from the physical dimensions and material of each calibration standard, or from its actual measured response. The parameters of the standards can be listed in Standards Definitions, Table 12-2.

Table 12-2. Standard Definitions

NO.	STANDARD TYPE	C0 ×10 ⁻¹⁵ F	C1 ×10 ⁻²⁷ F/Hz	C2 ×10 ⁻³⁶ F/Hz ²	OFFSET DELAY ps	OFFSET LOSS MΩ/s	OFFSET Z ₀ Ω	STANDARD LABEL
1								
2								
3								
4								
5								
6								
7								
8								

Each standard must be identified as one of five “types”: OPEN, SHORT, LOAD, DELAY/THRU, or arbitrary impedance.

Standard Type

■ OPEN

OPENS assigned a terminal impedance of infinite ohms, but delay and loss offsets may still be added. For information of the delay and loss offsets, see the “Offset and Delay” paragraph.

As a reflection standard, an OPEN offers the advantage of broadband frequency coverage. However, an OPEN rarely has perfect reflection characteristics because fringing (capacitance) effects cause phase shift that varies with frequency. This can be observed in measuring an OPEN termination after calibration, when an arc in the lower right circumference of the Smith chart indicates capacitive reactance. These effects are impossible to eliminate, but the calibration kit models include the OPEN termination capacitance at all frequencies for compatible calibration kits. The capacitance model is a second order polynomial (squared term), as a function of frequency, where the polynomial coefficients are user-definable. The capacitance model equation is:

$$C = C_0 + C_1 \times F + C_2 \times F^2$$

where F is the measurement frequency.

■ SHORT

SHORTs are assigned a terminal impedance of 0 Ω, but delay and loss offsets may still be added.

■ LOAD

LOADs are assigned a terminal impedance equal to the system characteristic impedance Z₀, but delay and loss offsets may still be added. If the LOAD impedance is not Z₀, use the arbitrary impedance standard definition.

■ DELAY/THRU

DELAY/THRUs are assigned a transmission line of specified length, for calibrating transmission measurements.

■ ARBITRARY IMPEDANCE

ARBITRARY IMPEDANCES are assigned a standard type (LOAD), but with an arbitrary impedance (different from system Z_0).

Offset and Delay

Offsets may be specified with any standard type. This means defining a uniform length of transmission line to exist between the standard being defined and the actual measurement plane. For reflection standards, the offset is assumed to be between the measurement plane and the standard (one-way only). For transmission standards, the offset is assumed to exist between the two reference planes (in effect, the offset is the THRU). Three characteristics of the offset can be defined: its delay (length), loss, and impedance.

- **Offset Delay** specifies the one-way electrical delay from the measurement (reference) plane to the standard, in seconds (s). (In a transmission standard, offset delay is the delay from plane to plane.) Delay can be calculated from the precise physical length of the offset, the permittivity constant of the medium, and the speed of light.
- **Offset Loss** specifies energy loss, due to skin effect, along a one-way length of coaxial cable offset. The value of loss is entered as ohms/nanosecond (or Giga ohms/second) at 1 GHz.
- **Offset Z_0** specifies the characteristic impedance of the coaxial cable offset. This is not the impedance of the standard itself.

Note

Numerical data for most Hewlett-Packard calibration kits is provided in the calibration kit manuals.



Specify Class

Once a standard is specified, it must be assigned to a standard *class*. This is a group of from one to seven standards that is required to calibrate for a single error term. The standards within a single class are assigned to locations A through G as listed on the Standard Class Assignments Table (Table 12-3). A class often consists of a single standard, but may be composed of more than one standard.

Table 12-3. Standard Class Assignments Table

CLASS	A	B	C	D	E	F	G	STANDARD CLASS LABEL
S _{11A}								
S _{11B}								
S _{11C}								
S _{22A}								
S _{22B}								
S _{22C}								
Forward Transmission								
Reverse Transmission								
Forward Match								
Reverse Match								
Response								
Response & Isolation								

The number of standard classes required depends on the type of calibration being performed, and is identical to the number of error terms corrected. (Examples: A response cal requires only one class, and the standards for that class may include an OPEN, or SHORT, or THRU. A 1-port cal requires three classes. A full 2-port cal requires 10 classes, not including two for isolation.)

The number of standards that can be assigned to a given class may vary from none (class not used) to one (simplest class) to seven. When a certain class of standards is required during calibration, the analyzer will display the labels for all the standards in that class (except when the class consists of a single standard). This does not, however, mean that all standards in a class must be measured during calibration. Only a single standard per class is required. Note that it is often simpler to keep the number of standards per class to the bare minimum needed (often one) to avoid confusion during calibration.

Standards are assigned to a class simply by entering the standard's reference number (established while defining a standard) under a particular class.

Each class can be given a user-definable label as described under "Modify Cal Kit Menu Network Analyzer" in Chapter 5.

Note

The class assignments table can be displayed on screen and printed using COPY function. (See "Copy Menu Network Analyzer Spectrum Analyzer" in Chapter 8.)

The standard class assignments of predefined standard kits are shown in Appendix D.

Note

Hewlett-Packard strongly recommends that you read application note 8510-5A before attempting to view or modify calibration standard definitions. The part number of this application note is 5956-4352. Although the application note is written for the HP 8510 family of network analyzers, it also applies to the analyzer.

Accuracy Enhancement Fundamentals-Characterizing Systematic Errors

One-Port Error Model

In a measurement of the reflection coefficient (magnitude and phase) of an unknown device, the measured data differs from the actual, no matter how carefully the measurement is made. Directivity, source match, and reflection signal path frequency response (tracking) are the major sources of error (Figure 12-26).

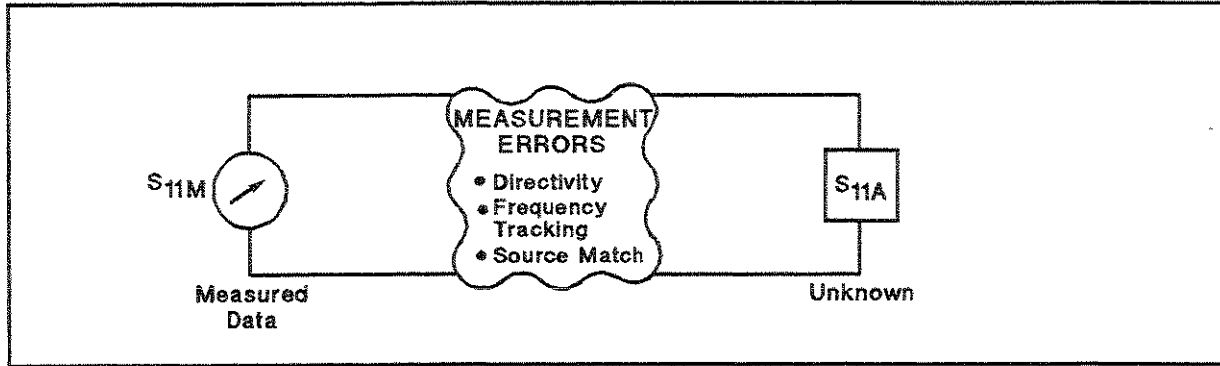

Figure 12-26. Sources of Error in a Reflection Measurement

Measuring reflection coefficient. The reflection coefficient is measured by first separating the incident signal (I) from the reflected signal (R), then taking the ratio of the two values (Figure 12-27). Ideally, (R) consists only of the signal reflected by the test device (S_{11A}).

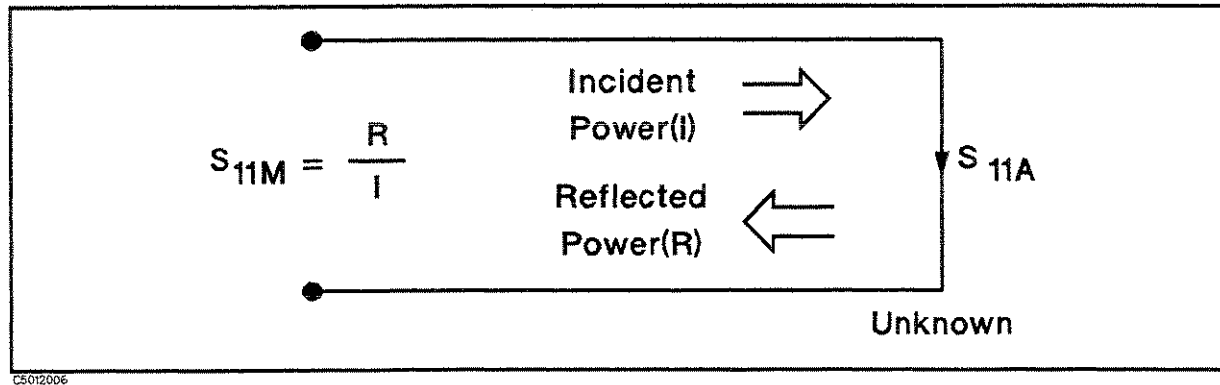
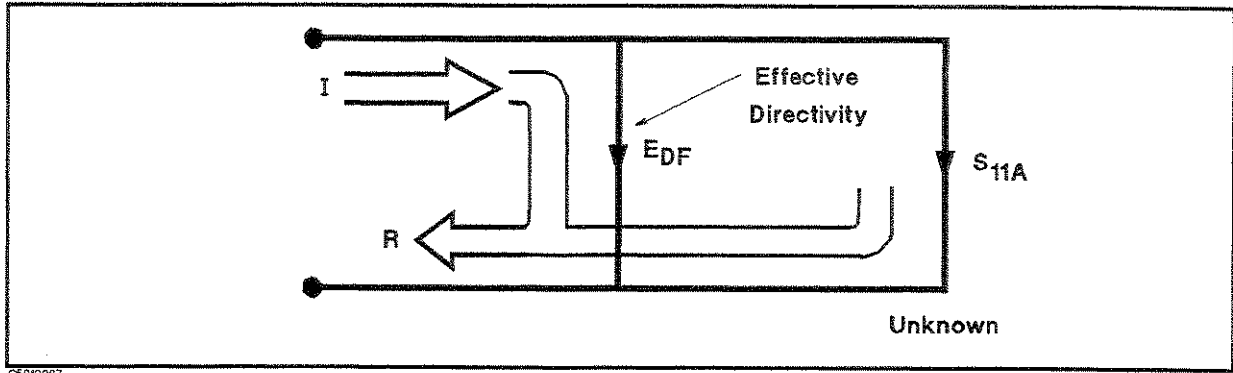

Figure 12-27. Reflection Coefficient

Directivity error. However, all of the incident signal does not always reach the unknown (see Figure 12-28). Some of (I) may appear at the measurement system input due to leakage through the test set or other signal separation device. Also, some of (I) may be reflected by imperfect adapters between signal separation and the measurement plane. The vector sum of the leakage and miscellaneous reflections is directivity, E_{DF} . Understandably, the measurement is distorted when the directivity signal combines vectorally with the actual reflected signal from the unknown, S_{11A} .



CS012007

Figure 12-28. Effective Directivity E_{DF}

Source match error. Because the measurement system test port is never exactly the characteristic impedance (50Ω or 75Ω), some of the reflected signal is re-reflected off the test port, or other impedance transitions further down the line, and back to the unknown, adding to the original incident signal (I). This effect causes the magnitude and phase of the incident signal to vary as a function of S_{11A} and frequency. Leveling the source to produce constant (I) reduces this error, but because the source cannot be exactly leveled at the test device input, leveling cannot eliminate all power variations. This re-reflection effect and the resultant incident power variation are caused by the source match error, E_{SF} (Figure 12-29).

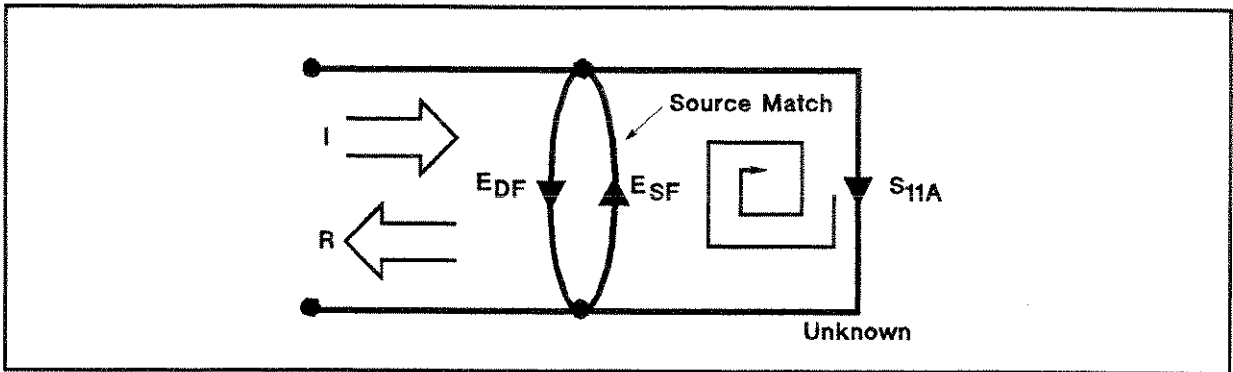

CS012008

Figure 12-29. Source Match E_{SF}

Frequency response error. Frequency response (tracking) error is caused by variations in magnitude and phase flatness versus frequency between the test and reference signal paths. These are due mainly to imperfectly matched receiver circuits and differences in length and loss between incident and test signal paths. The vector sum of these variations is the reflection path tracking error, E_{RF} (Figure 12-30).

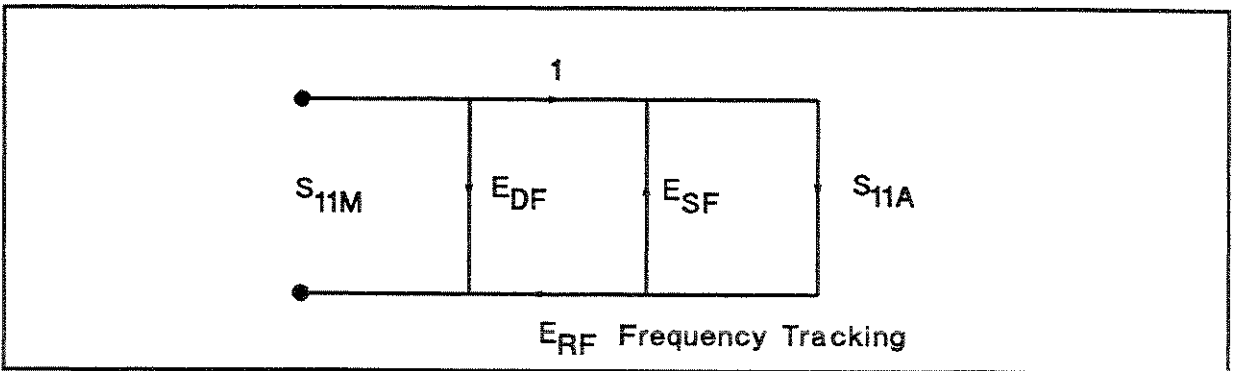

CS012009

Figure 12-30. Reflection Tracking E_{RF}

How calibration standards are used to quantify these error terms. It can be shown that these three errors are mathematically related to the actual data, S_{11A} , and measured data, S_{11M} , by the following equation:

$$S_{11M} = E_{DF} + \frac{S_{11A}(E_{RF})}{1 - E_{SF}S_{11A}}$$

If the value of these three “E” errors and the measured test device response were known for each frequency, the above equation could be solved for S_{11A} to obtain the actual test device response. Because each of these errors changes with frequency, their values must be known at each test frequency. These values are found by measuring the system at the measurement plane using three independent standards whose S_{11A} is known at all frequencies.

The first standard applied is a “perfect load” that makes $S_{11A} = 0$ and essentially measures directivity (Figure 12-31). “Perfect load” implies a reflectionless termination at the measurement plane. All incident energy is absorbed. With $S_{11A} = 0$ the equation can be solved for E_{DF} , the directivity term. In practice, of course, the “perfect load” is difficult to achieve, although very good broadband LOADs are available in the HP 4296A compatible calibration kits.

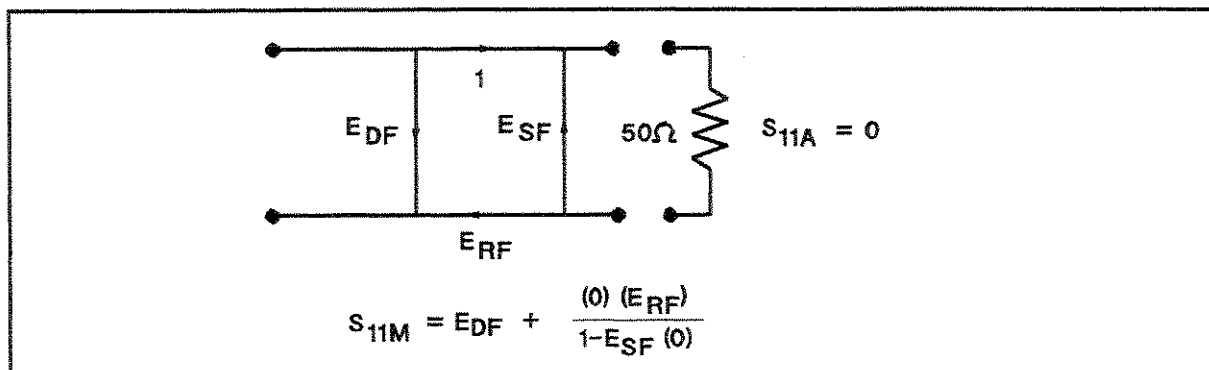
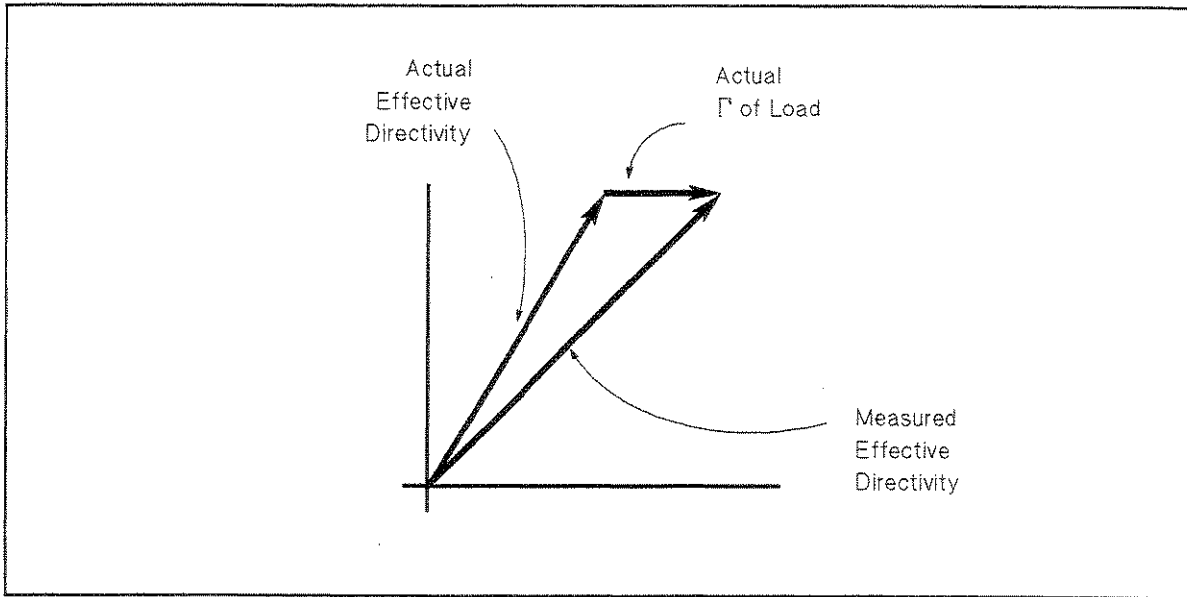

Figure 12-31. “Perfect Load” Termination

Because the measured value for directivity is the vector sum of the actual directivity plus the actual reflection coefficient of the “perfect load,” any reflection from the termination represents an error. System effective directivity becomes the actual reflection coefficient of the “perfect load” (Figure 12-32). In general, any termination having a return loss value greater than the uncorrected system directivity reduces reflection measurement uncertainty.



CS01201

Figure 12-32. Measured Effective Directivity

Next, a SHORT termination whose response is known to a very high degree establishes another condition (Figure 12-33).

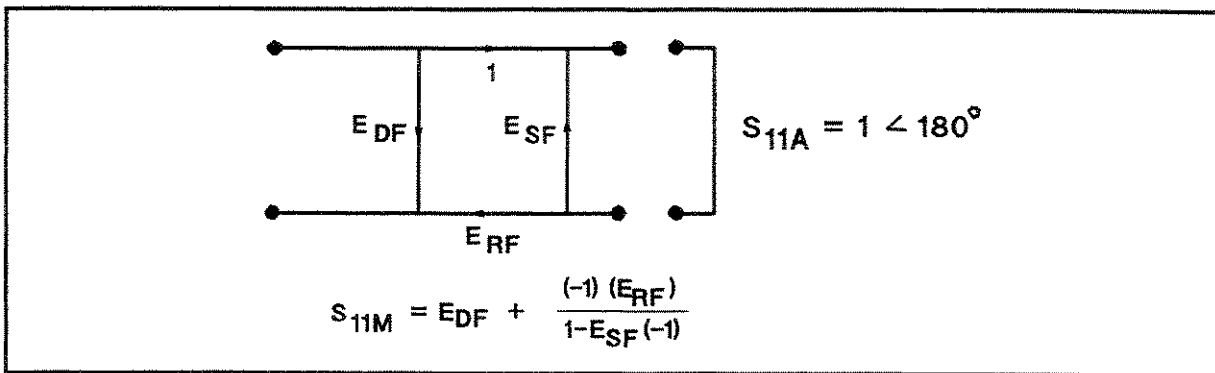

CS01202

Figure 12-33. Short Circuit Termination

The OPEN gives the third independent condition. In order to accurately model the phase variation with frequency due to radiation from the OPEN connector, a specially designed shielded OPEN is used for this step. (The OPEN capacitance is different with each connector type). Now the values for E_{DF} , directivity, E_{SF} , source match, and E_{RF} , reflection frequency response, are computed and stored (Figure 12-34).

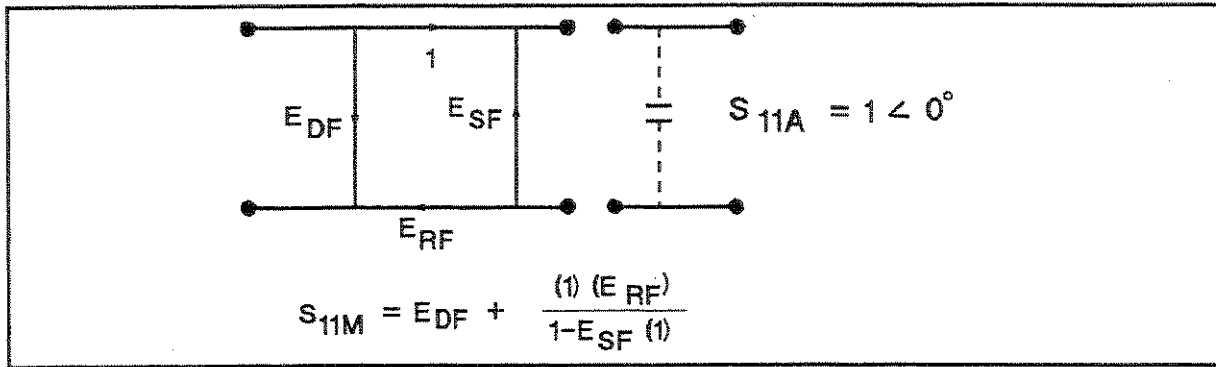

Figure 12-34. Open Circuit Termination

Now the unknown is measured to obtain a value for the measured response, S_{11M} , at each frequency (Figure 12-35).

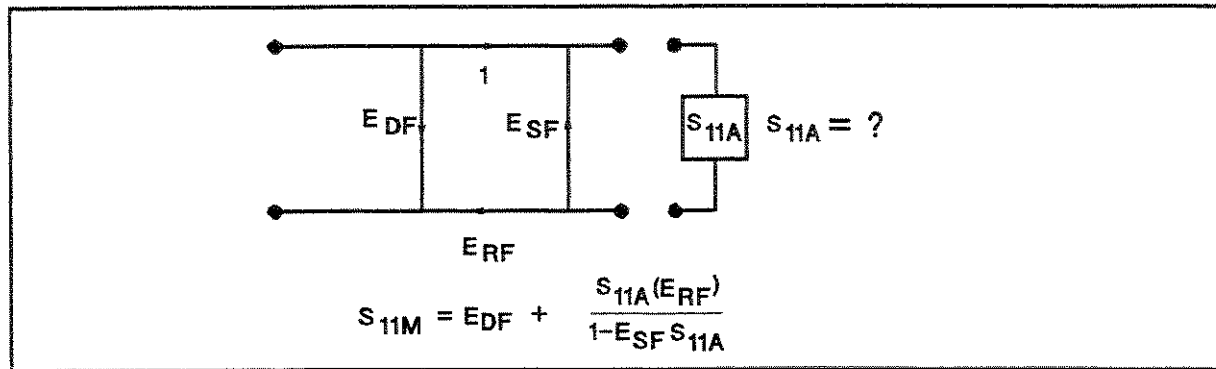

Figure 12-35. Measured S_{11}

This is the one-port error model equation solved for S_{11A} . Because the three errors and S_{11M} are now known for each test frequency, S_{11A} can be computed as follows

$$S_{11A} = \frac{S_{11M} - E_{DF}}{E_{SF}(S_{11M} - E_{DF}) + E_{RF}}$$

For reflection measurements on two-port devices, the same technique can be applied, but the test device output port must be terminated in the system characteristic impedance. This termination should be at least as good (have as low a reflection coefficient) as the LOAD used to determine directivity. The additional reflection error caused by an improper termination at the test device output port is not incorporated into one-port error model.

Two-Port Error Model

The error model for measurement of the transmission coefficients (magnitude and phase) of a two-port device is derived in a similar manner. The major sources of error are frequency response (tracking), source match, load match, and isolation (Figure 12-36). These errors are effectively removed using the full two-port error model

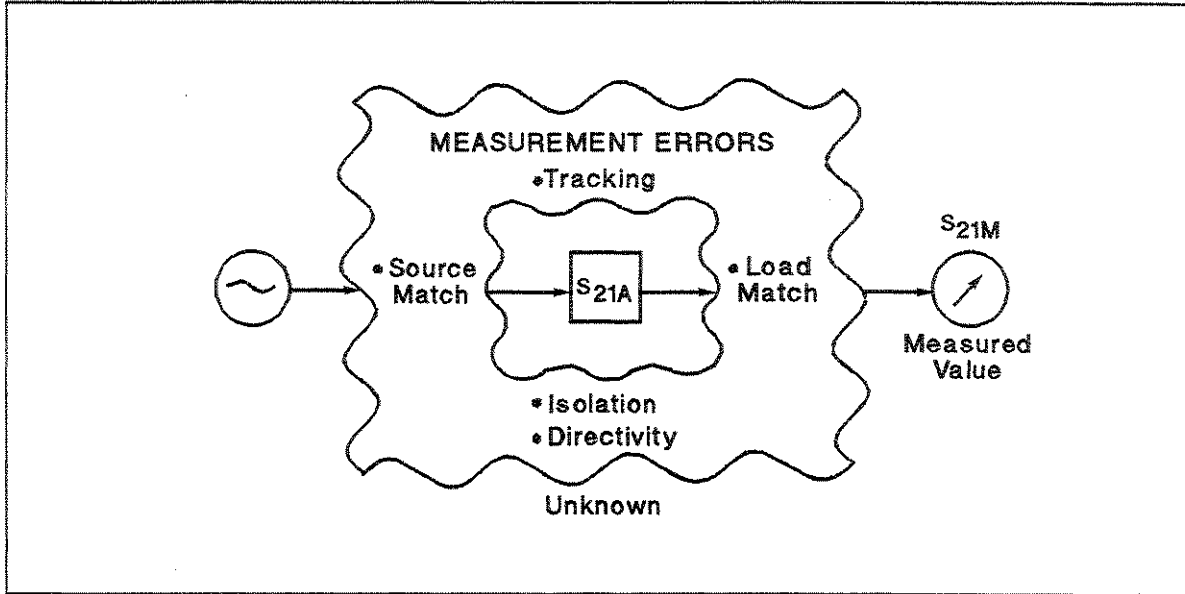

Figure 12-36. Major Sources of Error

Measuring Transmission Coefficient. The transmission coefficient is measured by taking the ratio of the incident signal (I) and the transmitted signal (T) (Figure 12-37). Ideally, (I) consists only of power delivered by the source, and (T) consists only of power emerging at the test device output.

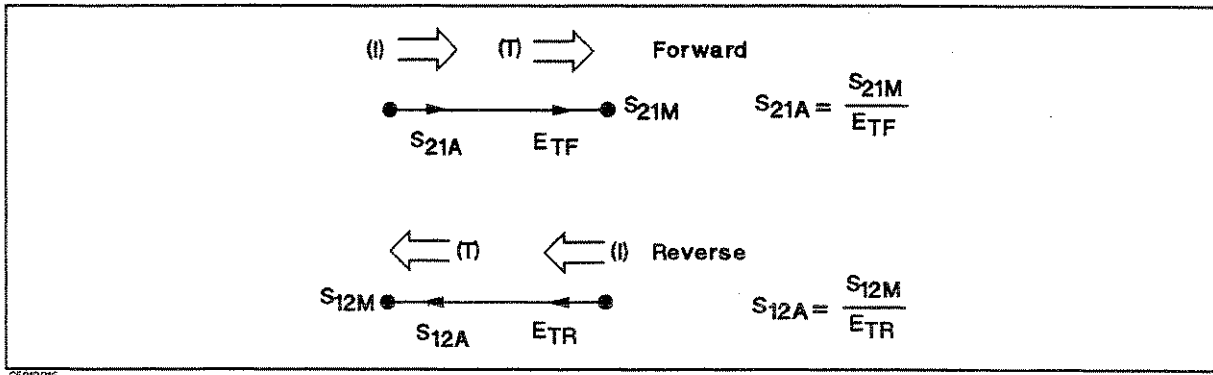
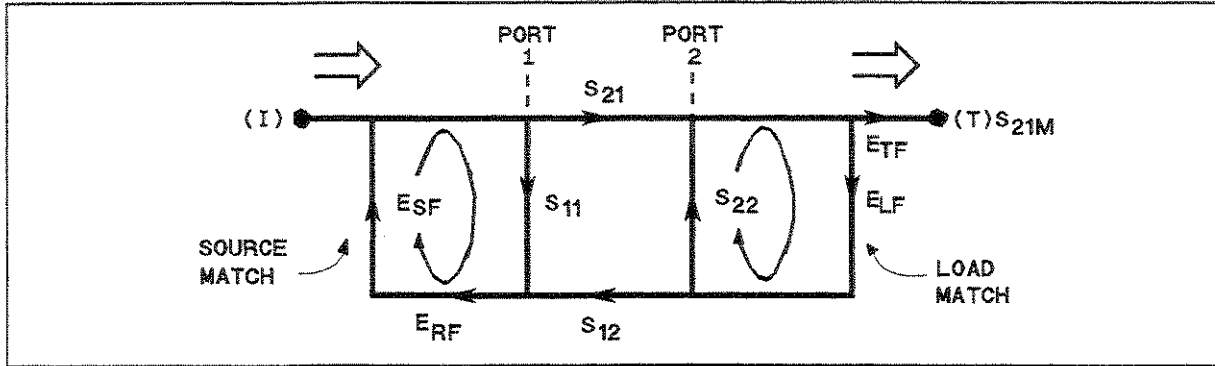

Figure 12-37. Transmission Coefficient

Load Match Error. As in the reflection model, source match can cause the incident signal to vary as a function of test device S_{11A} . Also, because the test setup transmission return port is never exactly the characteristic impedance, some of the transmitted signal is reflected from the test set port 2, and from other mismatches between the test device output and the receiver input, to return to the test device. A portion of this signal may be re-reflected at port 2, thus affecting S_{21M} , or part may be transmitted through the device in the reverse direction to appear at port 1, thus affecting S_{11M} . This error term, which causes the magnitude and phase of the transmitted signal to vary as a function of S_{22A} , is called load match, E_{LF} (Figure 12-38).



CS012017

Figure 12-38. Load Match E_{LF}

The measured value, S_{21M} , consists of signal components that vary as a function of the relationship between E_{SF} and S_{11A} as well as E_{LF} and S_{22A} , so the input and output reflection coefficients of the test device must be measured and stored for use in the S_{21A} error correction computation. Thus, the test setup is calibrated as described above for the reflection to establish the directivity, E_{DF} , source match, E_{SF} , and reflection frequency response, E_{RF} , terms for the reflection measurements.

Now, that a calibrated port is available for reflection measurements, the THRU is connected and load match, E_{LF} , is determined by measuring the reflection coefficient of the THRU connection.

Transmission signal path frequency response is then measured with the THRU connected. The data is corrected for source and load match effects, then stored as transmission frequency response, E_{TF} .

Isolation Errors. Isolation, E_{XF} , represents the part of the incident signal that appears at the receiver without actually passing through the test device (Figure 12-39). Isolation is measured with the test set in the transmission configuration and with terminations installed at the points where the test device will be connected.

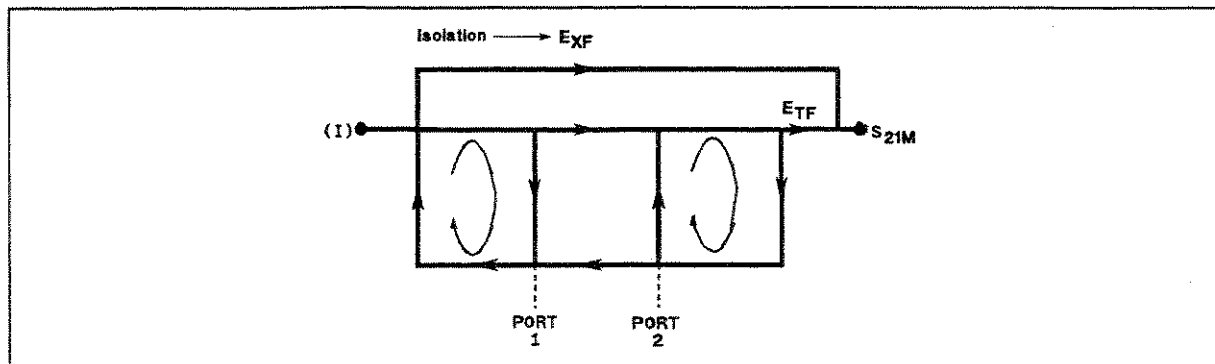

CS012016

Figure 12-39. Isolation E_{XF}

Error Terms the Analyzer Can Reduce. Thus there are two sets of error terms, forward and reverse, with each set consisting of six error terms, as follows:

- Forward
 - Directivity, E_{DF}
 - Isolation, E_{XF}
 - Source Match, E_{SF}
 - Load Match, E_{LF}
 - Transmission Tracking, E_{TF}
 - Reflection Tracking, E_{RF}

- Reverse
 - Directivity, E_{DR}
 - Isolation, E_{XR}
 - Source Match, E_{SR}
 - Load Match, E_{LR}
 - Transmission Tracking, E_{TR}
 - Reflection Tracking, E_{RR}

The HP 87511A, B S-parameter Test sets can measure both the forward and reverse characteristics of the test device without the need to manually remove and physically reverse it. With these test sets, the full two-port error model illustrated in Figure 12-40 effectively removes both the forward and reverse error terms for transmission and reflection measurements.

The HP 87512A, B Transmission/Reflection Test kits cannot switch between forward and reverse directions, so the reverse error terms cannot be automatically measured. Therefore, with the one-path two-port calibration, the forward error terms are duplicated and used for both forward and reverse measurements by manually reversing the test device.

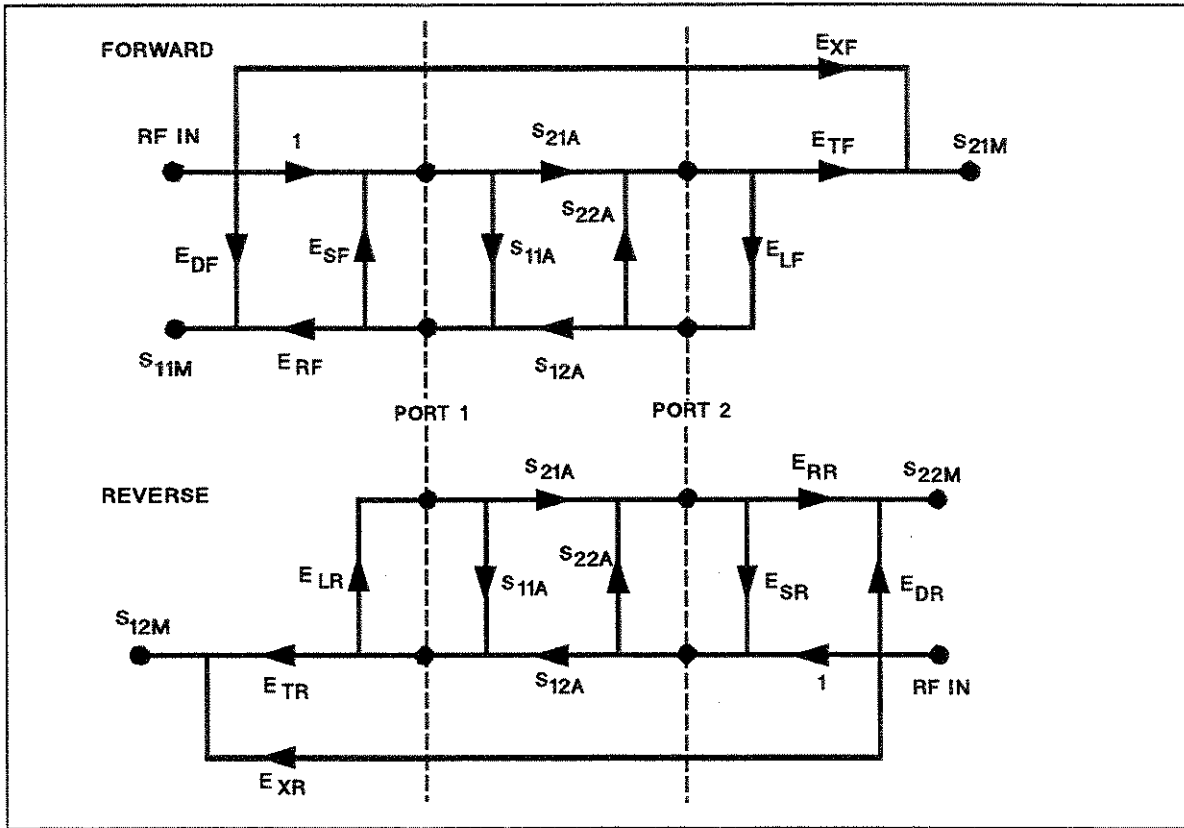

Figure 12-40. Full Two-Port Error Model

The following equations show the full two-port error model equations for all four S-parameters of a two-port device. Note that the mathematics for this comprehensive model use all forward and reverse error terms and measured values. Thus, to perform full error correction for any one parameter, all four S-parameters must be measured.

$$S_{11A} = \frac{\left[\left(\frac{S_{11M}-EDF}{ERF} \right) \left[1 + \left(\frac{S_{22M}-EDR}{ERR} \right) E_{SR} \right] - \left[\left(\frac{S_{21M}-EXF}{ETF} \right) \left(\frac{S_{12M}-EXR}{ETR} \right) E_{LF} \right] \right]}{\left[1 + \left(\frac{S_{11M}-EDF}{ERF} \right) E_{SF} \right] \left[1 + \left(\frac{S_{22M}-EDR}{ERR} \right) E_{SR} \right] - \left[\left(\frac{S_{21M}-EXF}{ETF} \right) \left(\frac{S_{12M}-EXR}{ETR} \right) E_{LF} E_{LR} \right]}$$

$$S_{21A} = \frac{\left[1 + \left(\frac{S_{22M}-EDR}{ERR} \right) (E_{SR} - E_{LF}) \right] \left(\frac{S_{21M}-EXF}{ETF} \right)}{\left[1 + \left(\frac{S_{11M}-EDF}{ERF} \right) E_{SF} \right] \left[1 + \left(\frac{S_{22M}-EDR}{ERR} \right) E_{SR} \right] - \left[\left(\frac{S_{21M}-EXF}{ETF} \right) \left(\frac{S_{12M}-EXR}{ETR} \right) E_{LF} E_{LR} \right]}$$

$$S_{12A} = \frac{\left[1 + \left(\frac{S_{11M}-EDF}{ERF} \right) (E_{SF} - E_{LR}) \right] \left(\frac{S_{12M}-EXR}{ETR} \right)}{\left[1 + \left(\frac{S_{11M}-EDF}{ERF} \right) E_{SF} \right] \left[1 + \left(\frac{S_{22M}-EDR}{ERR} \right) E_{SR} \right] - \left[\left(\frac{S_{21M}-EXF}{ETF} \right) \left(\frac{S_{12M}-EXR}{ETR} \right) E_{LF} E_{LR} \right]}$$

$$S_{22A} = \frac{\left[\left(\frac{S_{22M}-EDR}{ERR} \right) \left[1 + \left(\frac{S_{11M}-EDF}{ERF} \right) E_{SF} \right] - \left[\left(\frac{S_{21M}-EXF}{ETF} \right) \left(\frac{S_{12M}-EXR}{ETR} \right) E_{LF} \right] \right]}{\left[1 + \left(\frac{S_{11M}-EDF}{ERF} \right) E_{SF} \right] \left[1 + \left(\frac{S_{22M}-EDR}{ERR} \right) E_{SR} \right] - \left[\left(\frac{S_{21M}-EXF}{ETF} \right) \left(\frac{S_{12M}-EXR}{ETR} \right) E_{LF} E_{LR} \right]}$$

In addition to the errors removed by accuracy enhancement, other systematic errors exist due to limitations of dynamic accuracy, test set switch repeatability, and test cable stability. These, combined with random errors, also contribute to total system measurement uncertainty. Therefore, after accuracy enhancement procedures are performed, residual measurement uncertainties remain.

I/O PORT

The I/O port on the analyzer rear panel communicates with the external devices such as a handler on a production line.

Pin Assignment

The I/O port consists of 15 TTL compatible signals, which are 8-bit output, 4-bit input, and ground. The pin assignments are shown in Figure 12-41.

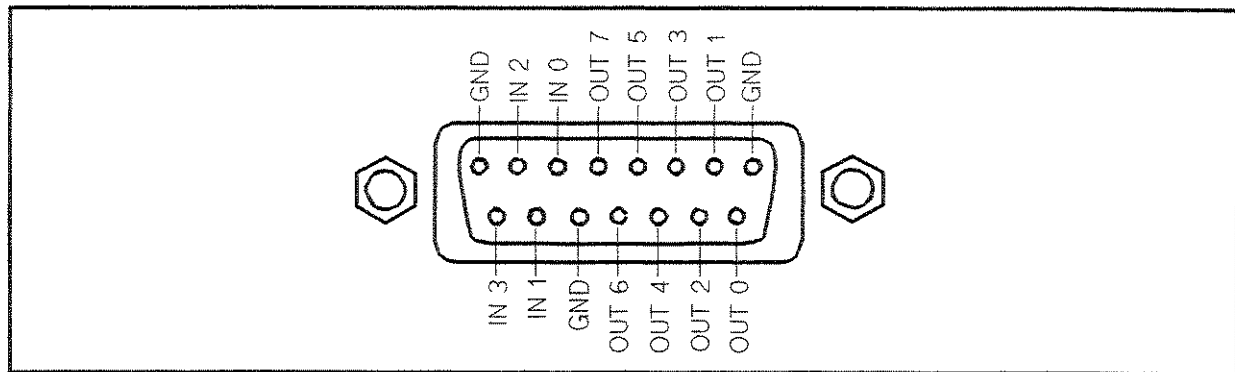

Figure 12-41. I/O Port Pin Assignments

The signals carried through each pin are described below.

- | | |
|--------------|---|
| OUT 0 thru 7 | output signals to external devices and are controlled by two HP-IB commands, OUT8IO, as described below. Once OUT8IO is executed, the signal is latched until OUT8IO is executed again. |
| IN 0 thru 4 | input signals from external devices and are read by the HP-IB command INP8IO?, as described below. |

Related HP-IB Commands

There are three HP-IB commands that directly control an I/O port.

- | | |
|---------|--|
| OUT8IO | outputs 8-bit data to the OUT 0 thru 7 lines. The OUT 0 signal is the LSB (least significant bit), while the OUT 7 signal is the MSB (most significant bit). |
| INP8IO? | inputs data from the 4-bit parallel input port to the analyzer, and outputs the data to the controller. |

Manual Changes

Introduction

This appendix contains the information required to adapt this manual to earlier versions or configurations of the analyzer than the current printing date of this manual. The information in this manual applies directly to the HP 4396B Network/Spectrum Analyzer serial number prefix listed on the title page of this manual.

Manual Changes

To adapt this manual to your HP 4396B, see Table A-1 and Table A-2, and make all the manual changes listed opposite your instrument's serial number and firmware version.

Instruments manufactured after the printing of this manual may be different from those documented in this manual. Later instrument versions will be documented in a manual changes supplement that will accompany the manual shipped with that instrument. If your instrument's serial number is not listed on the title page of this manual or in Table A-1, it may be documented in a *yellow MANUAL CHANGES* supplement.

In additions to change information, the supplement may contain information for correcting errors (Errata) in the manual. To keep this manual as current and accurate as possible, Hewlett-Packard recommends that you periodically request the latest *MANUAL CHANGES* supplement.

For information concerning serial number prefixes not listed on the title page or in the *MANUAL CHANGE* supplement, contact the nearest Hewlett-Packard office.

Turn on the line switch or execute the *IDN? command by HP-IB to confirm the firmware version. See the *HP-IB Command Reference* manual for information on the *IDN? command.

Table A-1. Manual Changes by Serial Number

Serial Prefix or Number	Make Manual Changes
JP1KE	

Table A-2. Manual Changes by Firmware Version

Version	Make Manual Changes
1.00	Changes 1
1.01	Changes 2

Serial Number

Hewlett-Packard uses a two-part, nine-character serial number that is stamped on the serial number plate (see Figure A-1) attached to the rear panel. The first four digits and the letter are the serial prefix and the last five digits are the suffix.

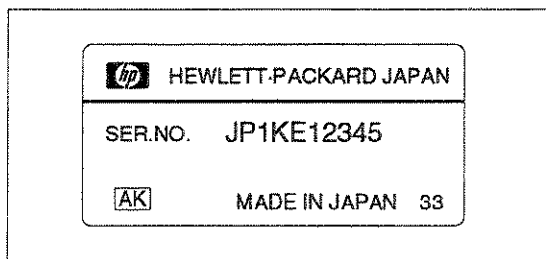

Figure A-1. Serial Number Plate

Changes 1

Page 8-38

Delete the following description.

4396A STATE (SAVDSTAC)

Saves the instrument state and the internal data arrays in the format so that the 4396A can recall.

Note

Following settings are not saved.



- Printing resolution (dpi)
- Sheet orientation
- Form feed
- Top margin
- Left margin
- Softkey label printing

Page 8-31, Figure 8-17

Change the figure as follows.

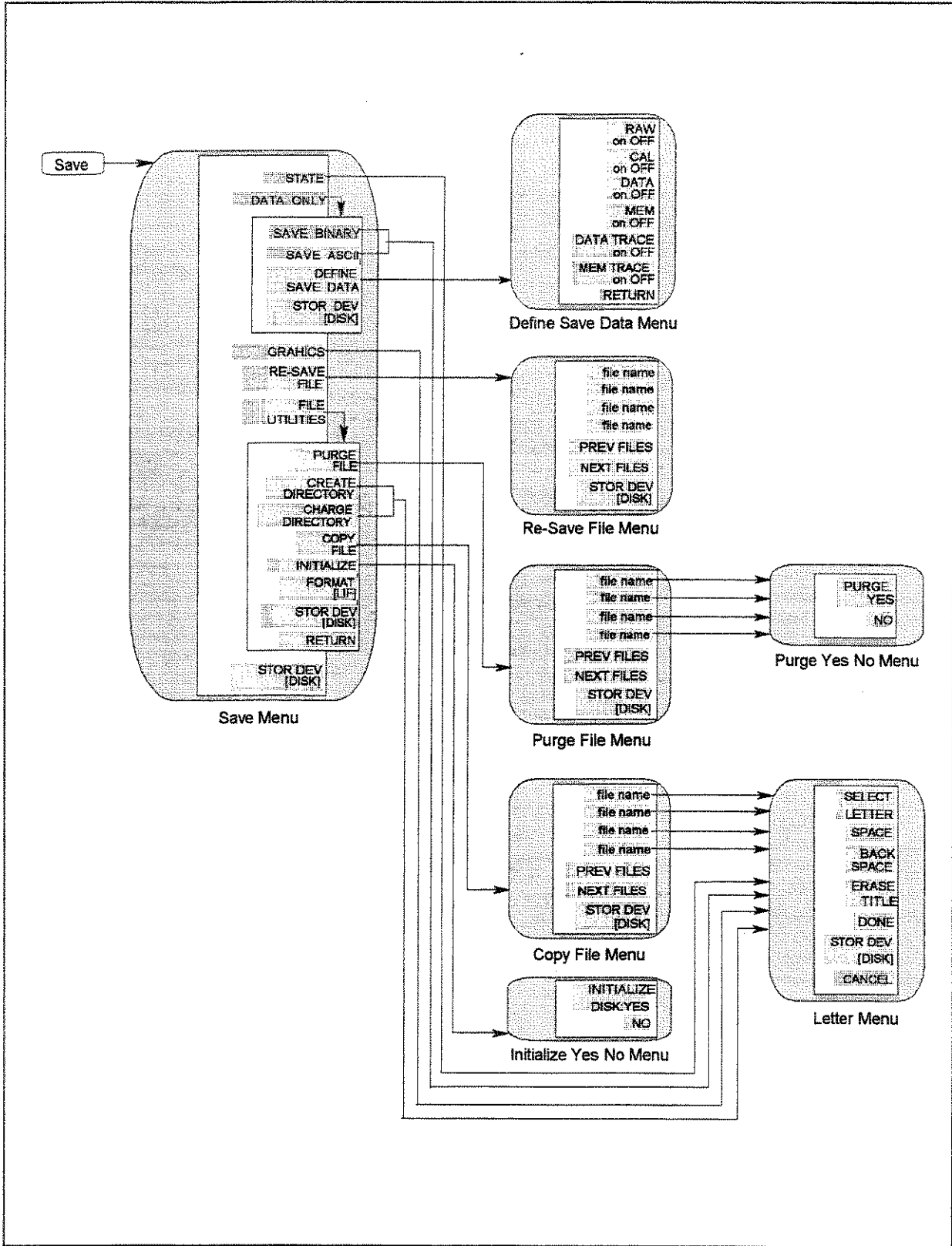

Figure 8-17. Softkey Menus Accessed from the **Save** Key.

Recall

Page 8-32, Figure 8-18

Change the figure as follows.

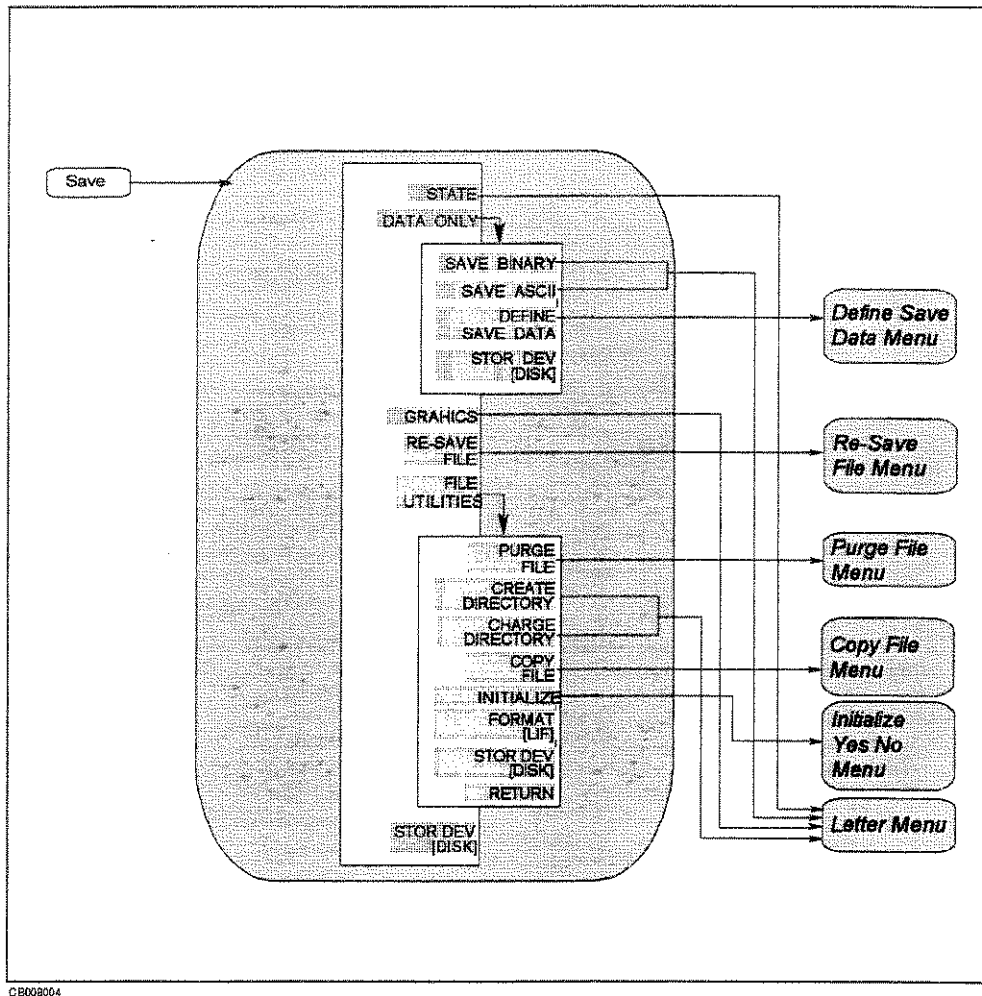

Figure 8-18. Save Menu

Changes 2

Page 8-33

Change the following description.

GRAPHICS (SAVDTIFF)

Specifies the file format for saving the screen currently displayed as the TIFF format. The traces and background are saved in specified colors. Softkeys are also saved.

Softkey Tree

Measurement Block

Meas

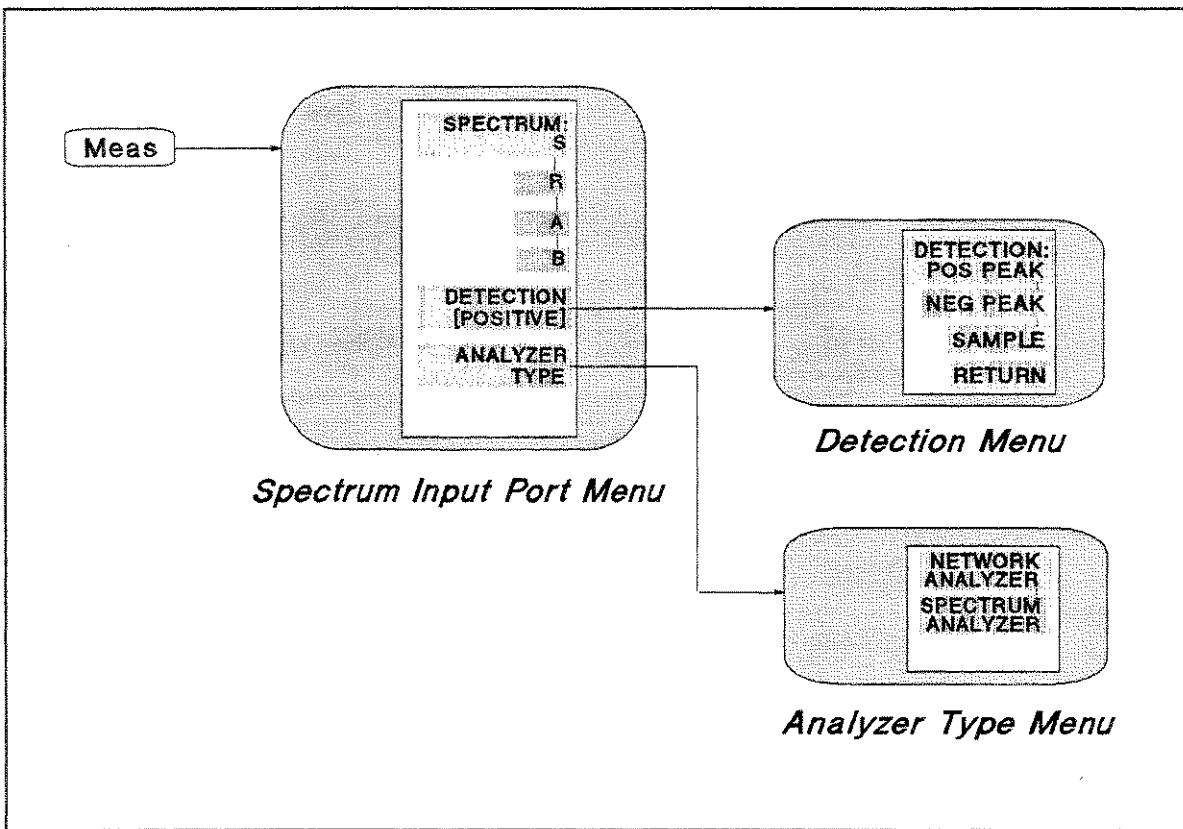

05065034

Figure B-1. Softkey Menus Accessed from the Meas Key for Spectrum Analyzer

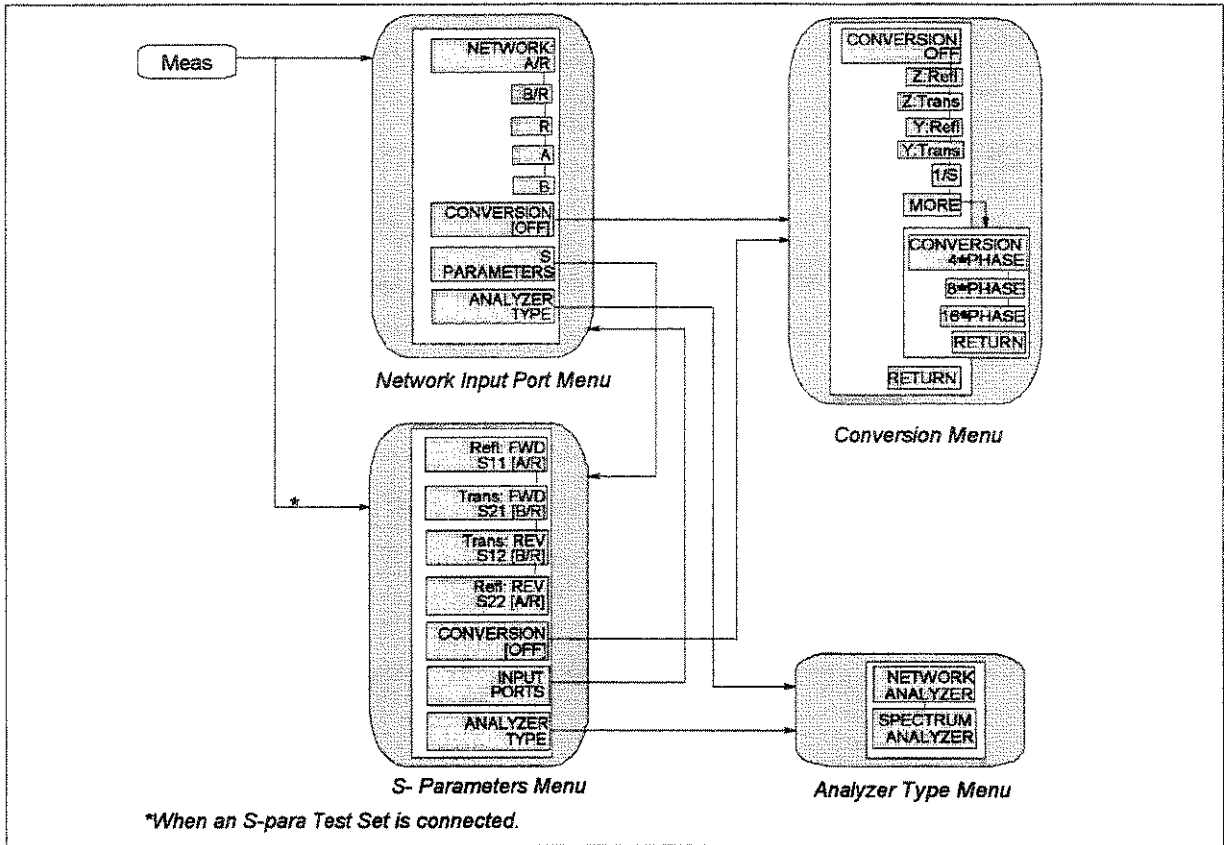

Figure B-2. Softkey Menus Accessed from the Meas Key for Network Analyzer

Format

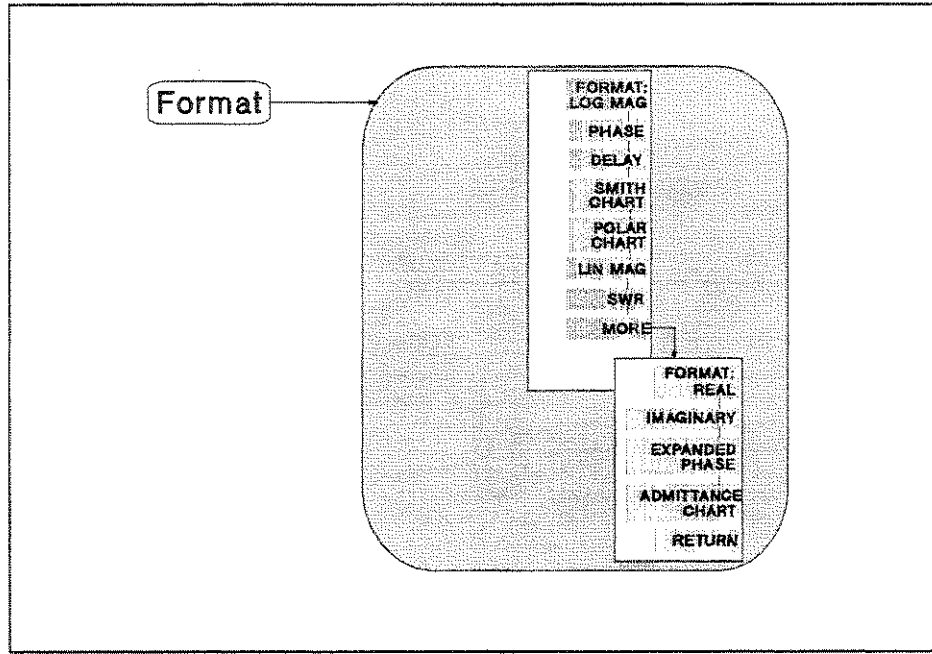

Figure B-3. Softkey Menus Accessed from the **Format** Key for Spectrum Analyzer

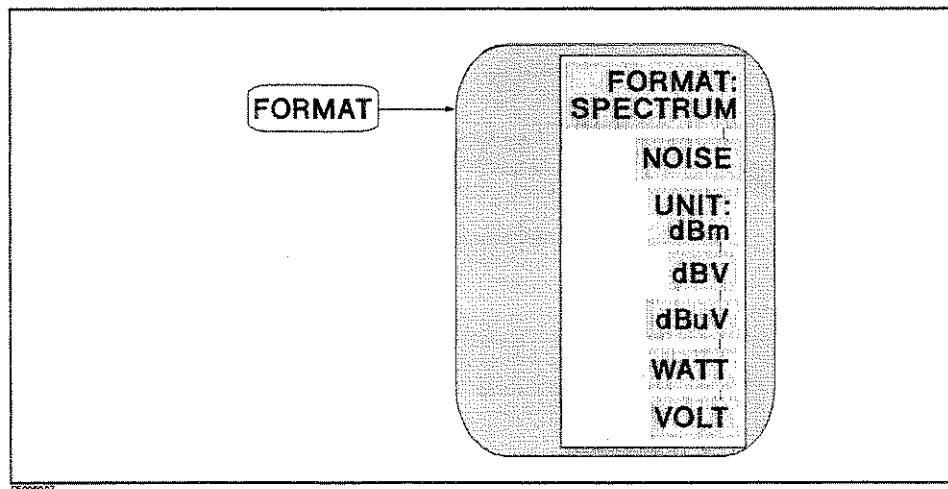
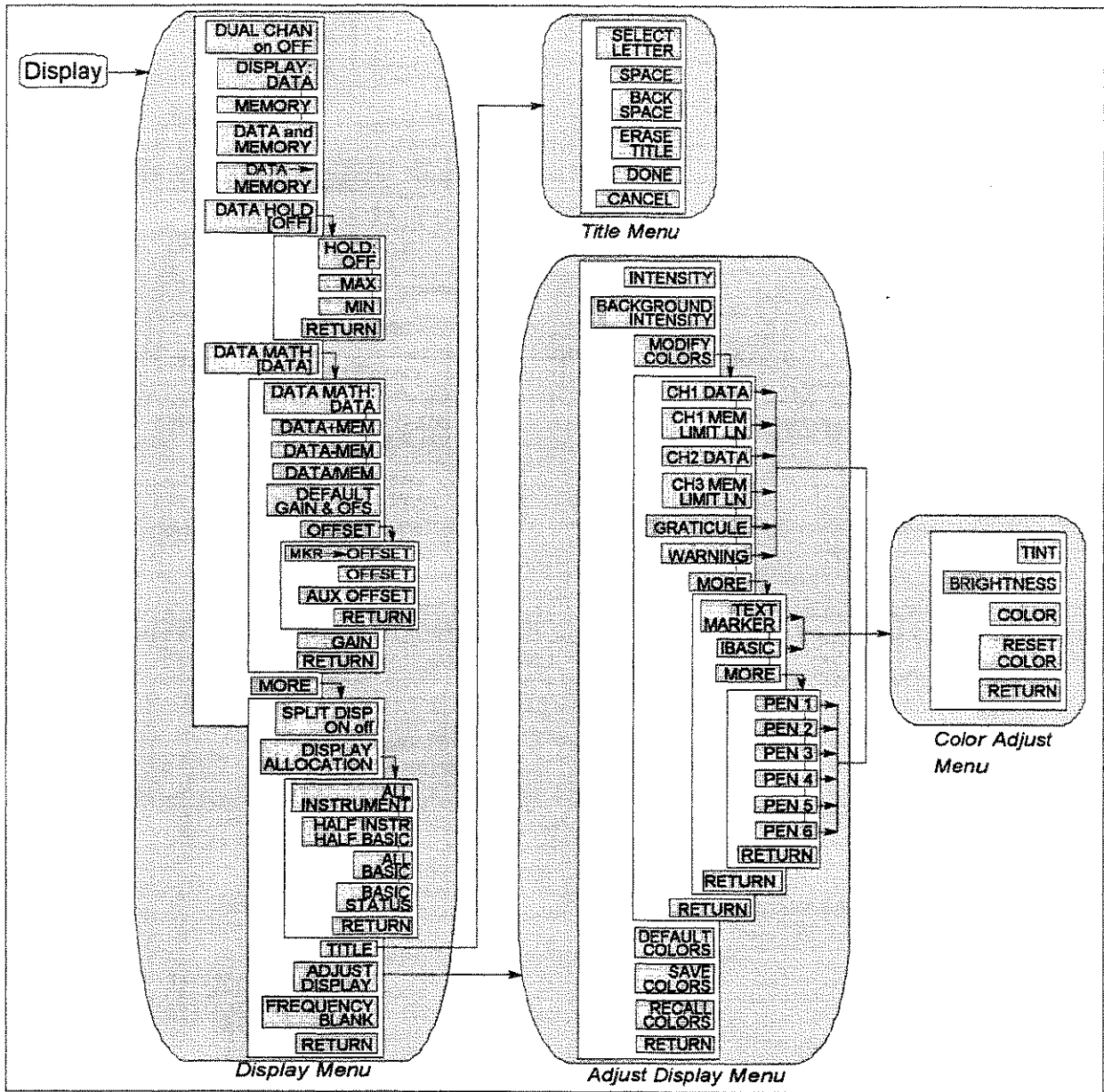

Figure B-4. Softkey Menus Accessed from the **Format** Key for Network Analyzer

B. Softkey Tree

Display



CB005035

Figure B-5. Softkey Menus Accessed from the **Display** Key

Scale Ref

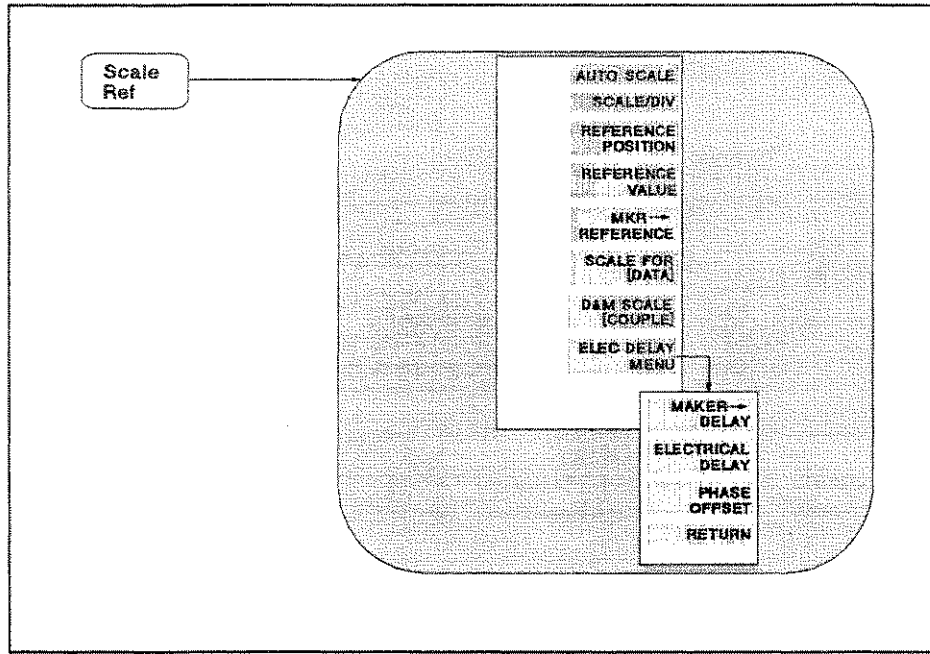

Figure B-6. Softkey Menus Accessed from the **Scale Ref** Key for Network Analyzer

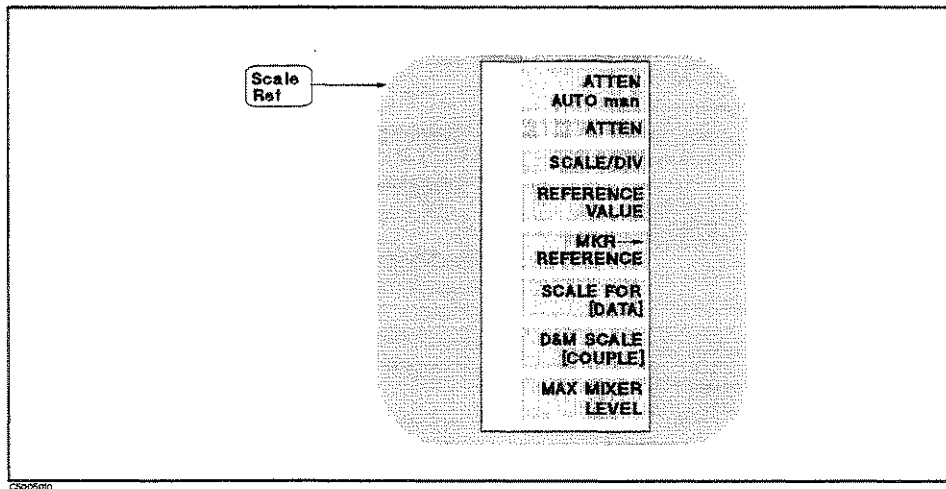

Figure B-7. Softkey Menus Accessed from the **Format** Key for Spectrum Analyzer

Bw/Avg

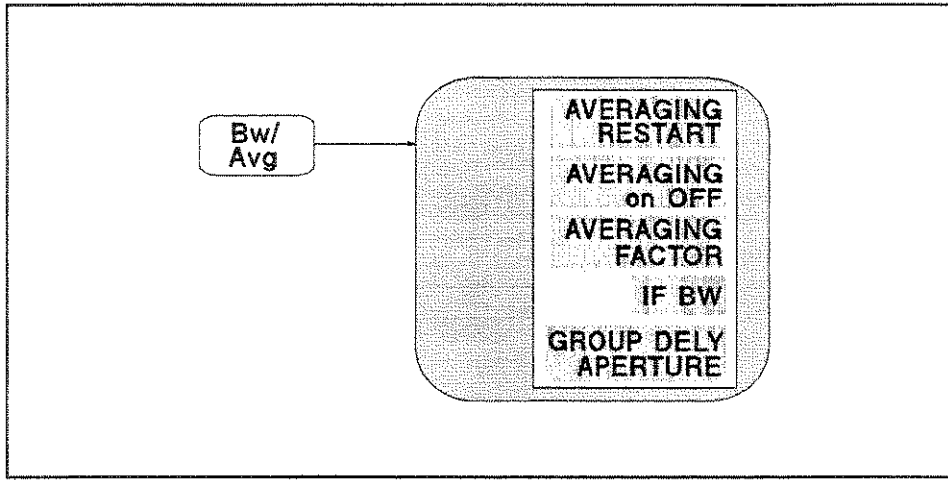

Figure B-8. Softkey Menus Accessed from the **Bw/Avg** Key for Network Analyzer

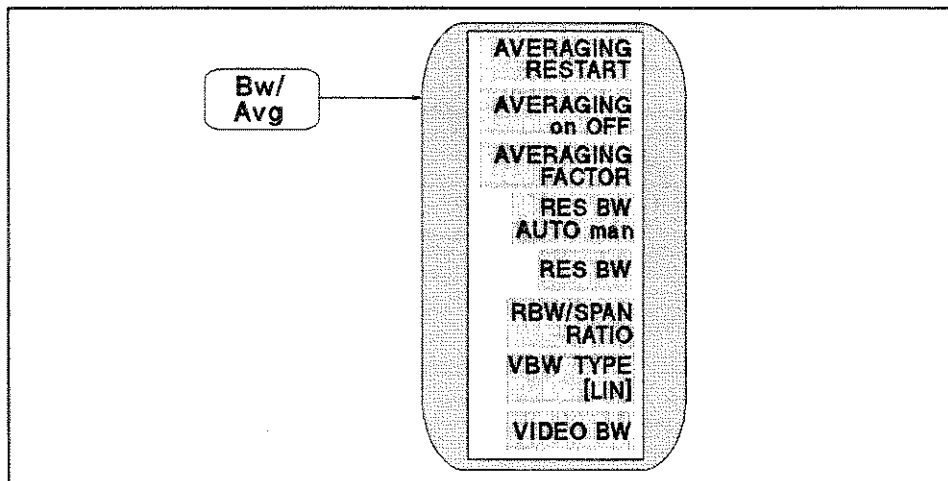

Figure B-9. Softkey Menus Accessed from the **Bw/Avg** Key for Spectrum Analyzer

Cal

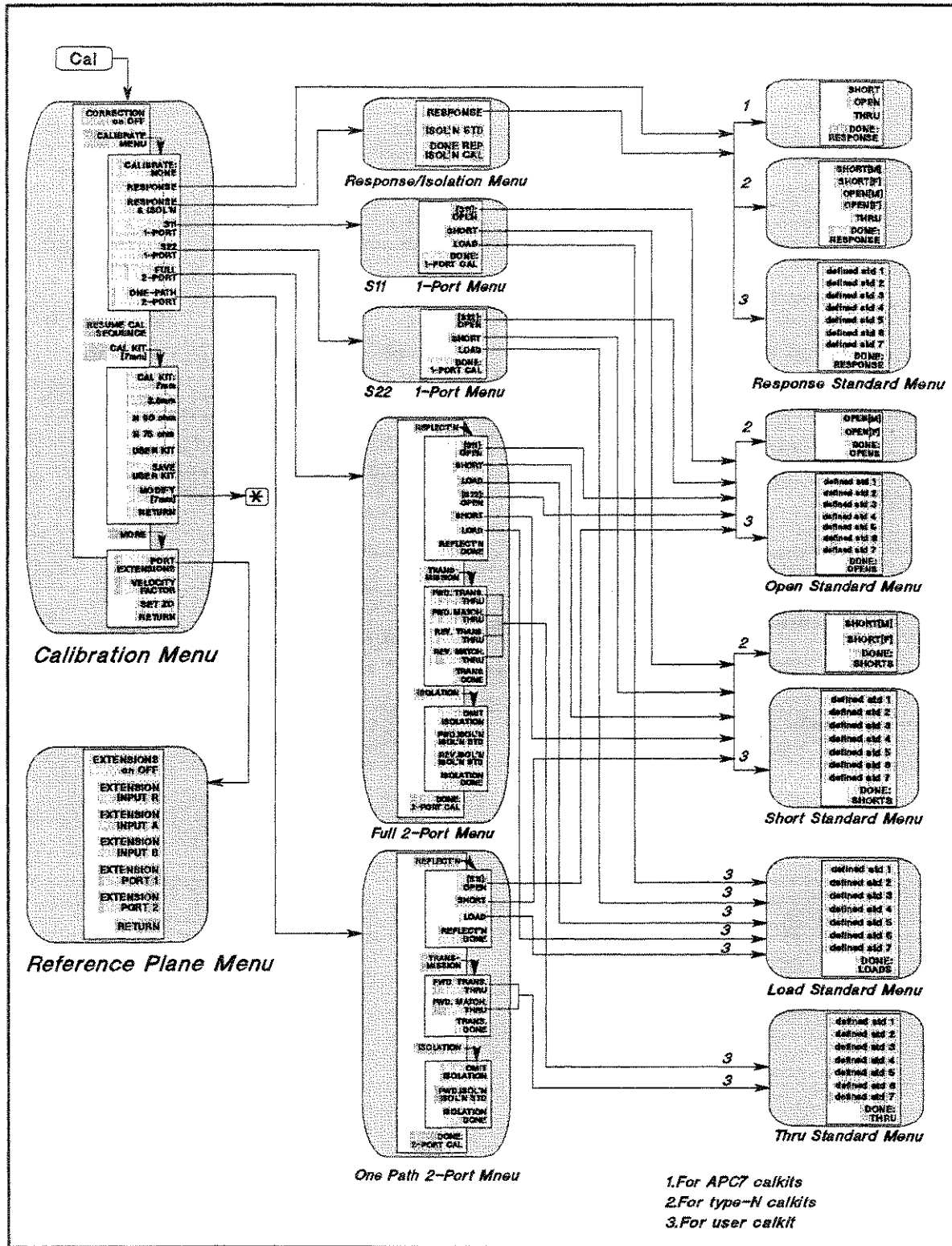

Figure B-10. Softkey Menus Accessed from the [Cal] Key for Network Analyzer (1/2)

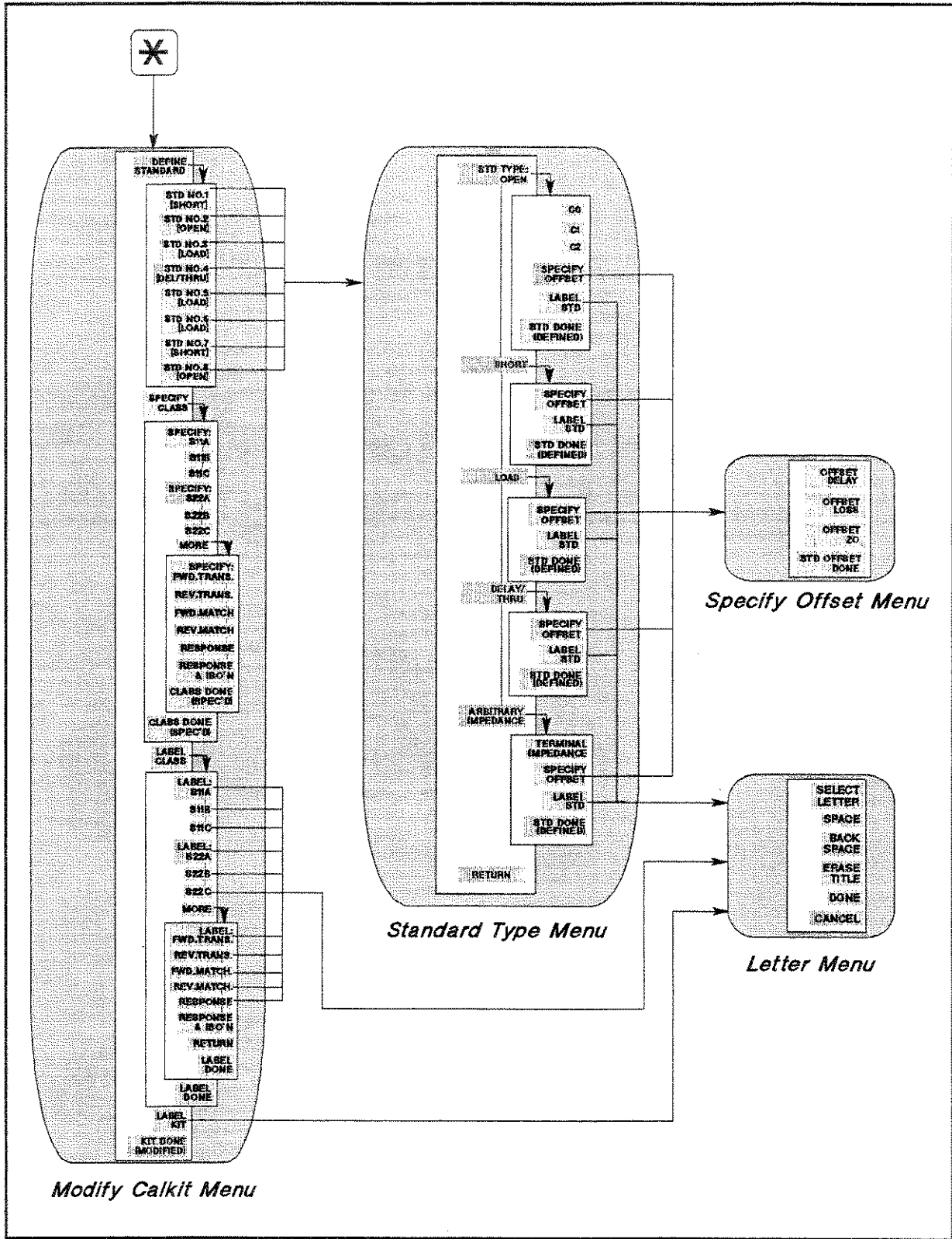
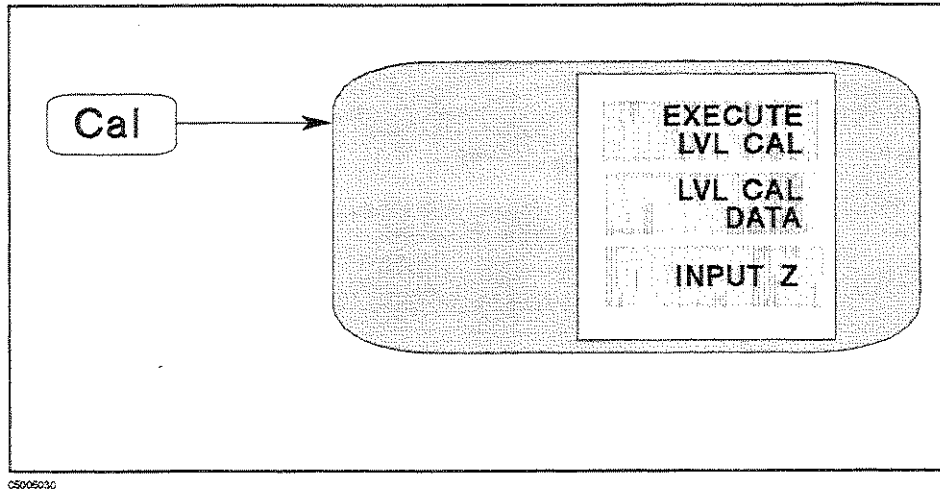

Figure B-11. Softkey Menus Accessed from the **[Cal]** Key for Network Analyzer (2/2)



CS905530

Figure B-12. Softkey Menus Accessed from the **Cal** Key for Spectrum Analyzer

Sweep Block

Center

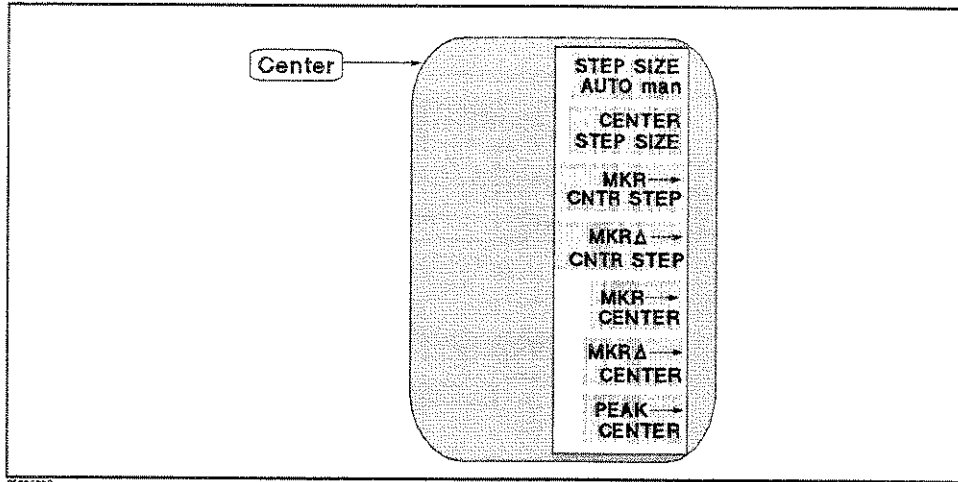

Figure B-13. Softkey Menus Accessed from the **Center** Key

Span

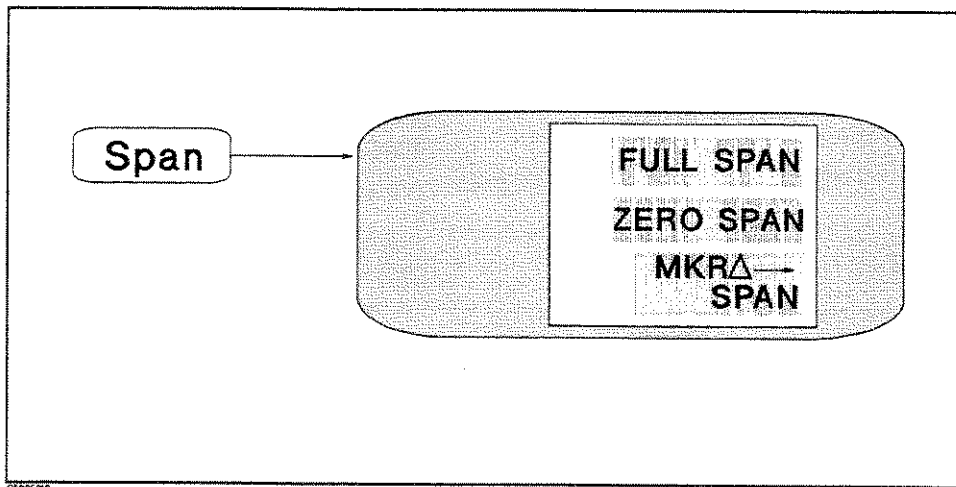
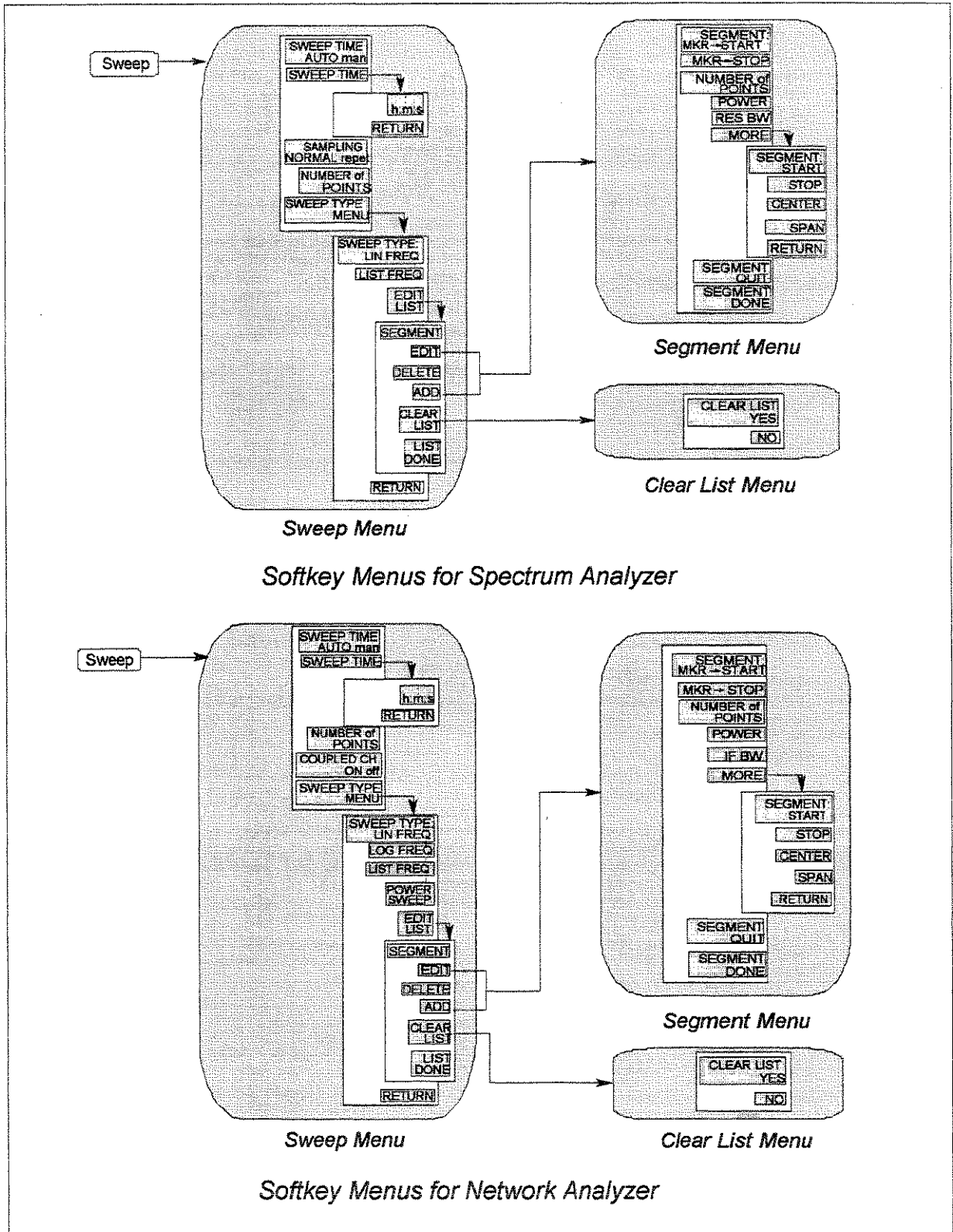

Figure B-14. Softkey Menus Accessed from the **Span** Key

Sweep



Softkey Menus for Spectrum Analyzer

Softkey Menus for Network Analyzer

CB00011

Figure B-15. Softkey Menus Accessed from the **Sweep** Key

B. Softkey Tree

Source

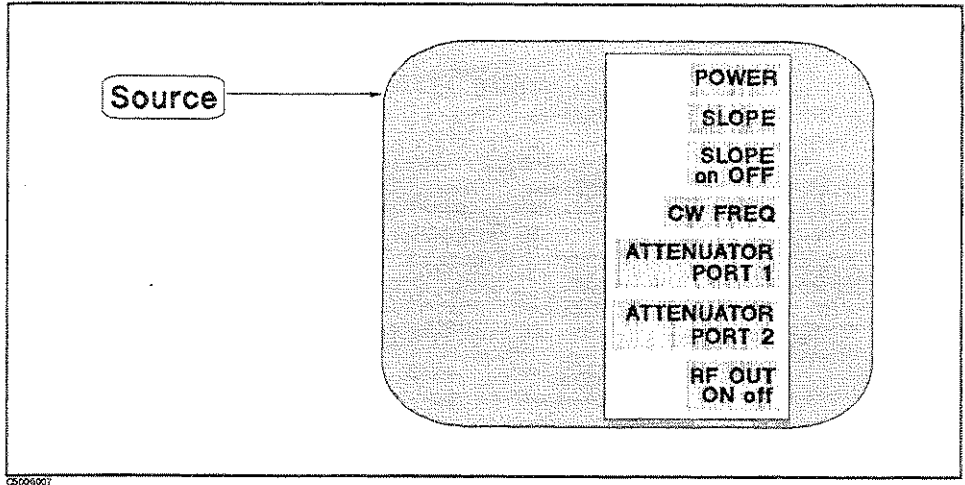

Figure B-16. Softkey Menus Accessed from the **Source** Key for Network Analyzer

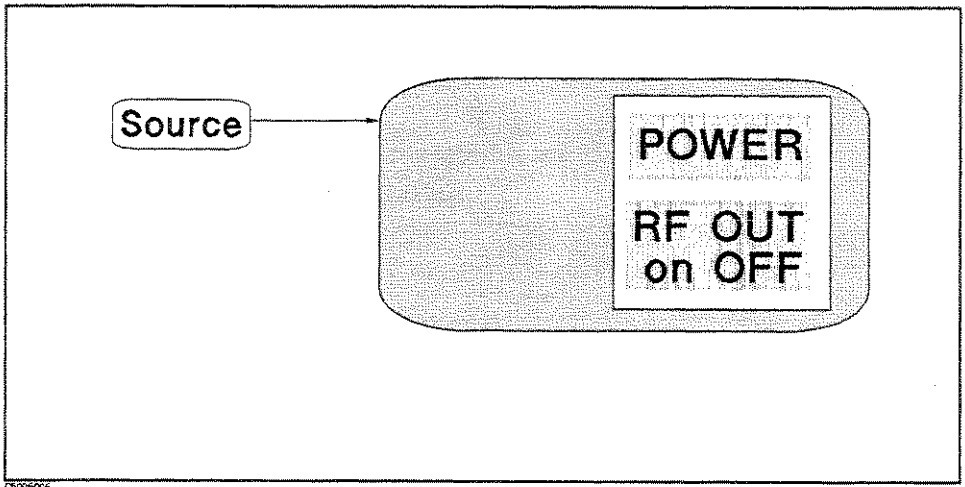

Figure B-17. Softkey Menus Accessed from the **Source** Key for Spectrum Analyzer

Trigger

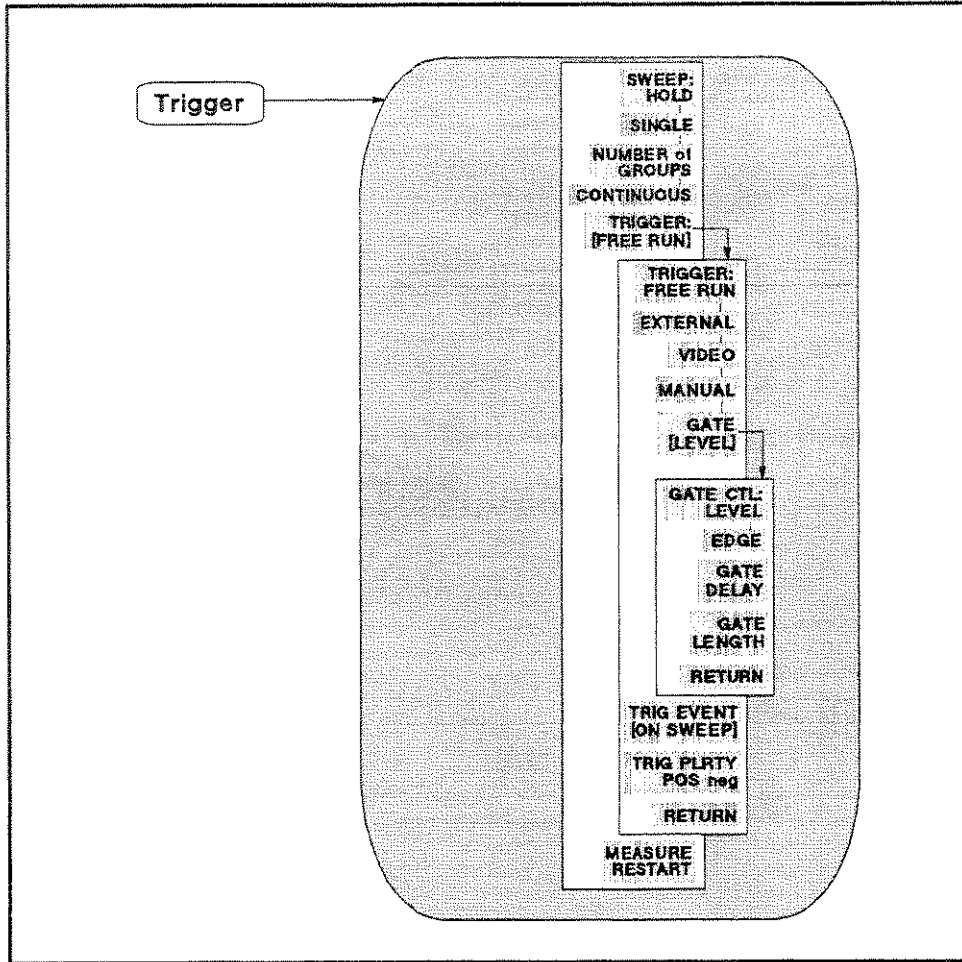

Figure B-18. Softkey Menus Accessed from the Trigger Key

Marker Block

Marker

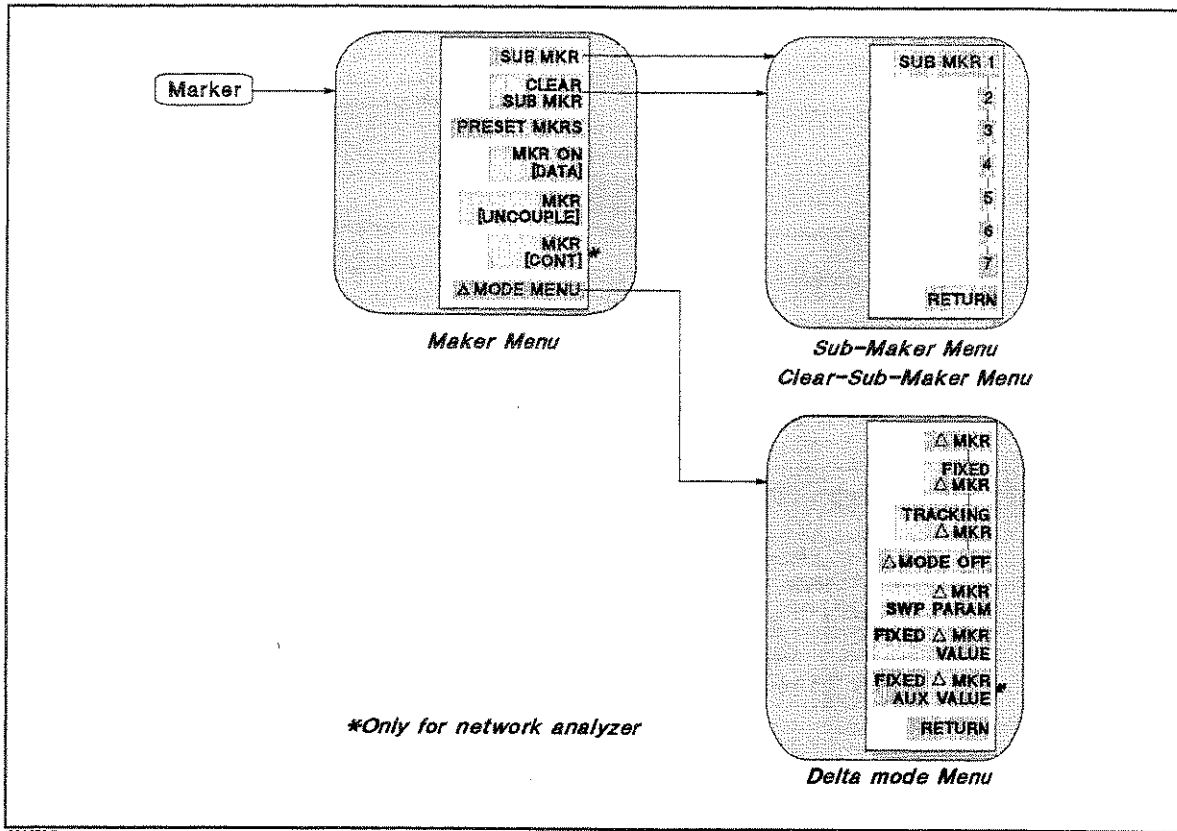

Figure B-19. Softkey Menus Accessed from the **Marker** Key

Marker →

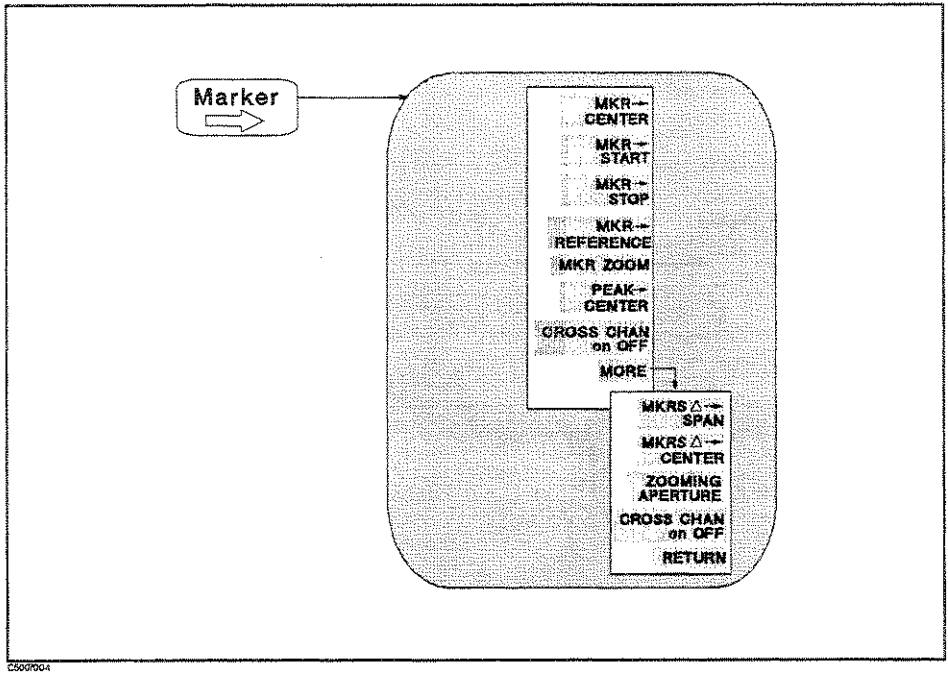
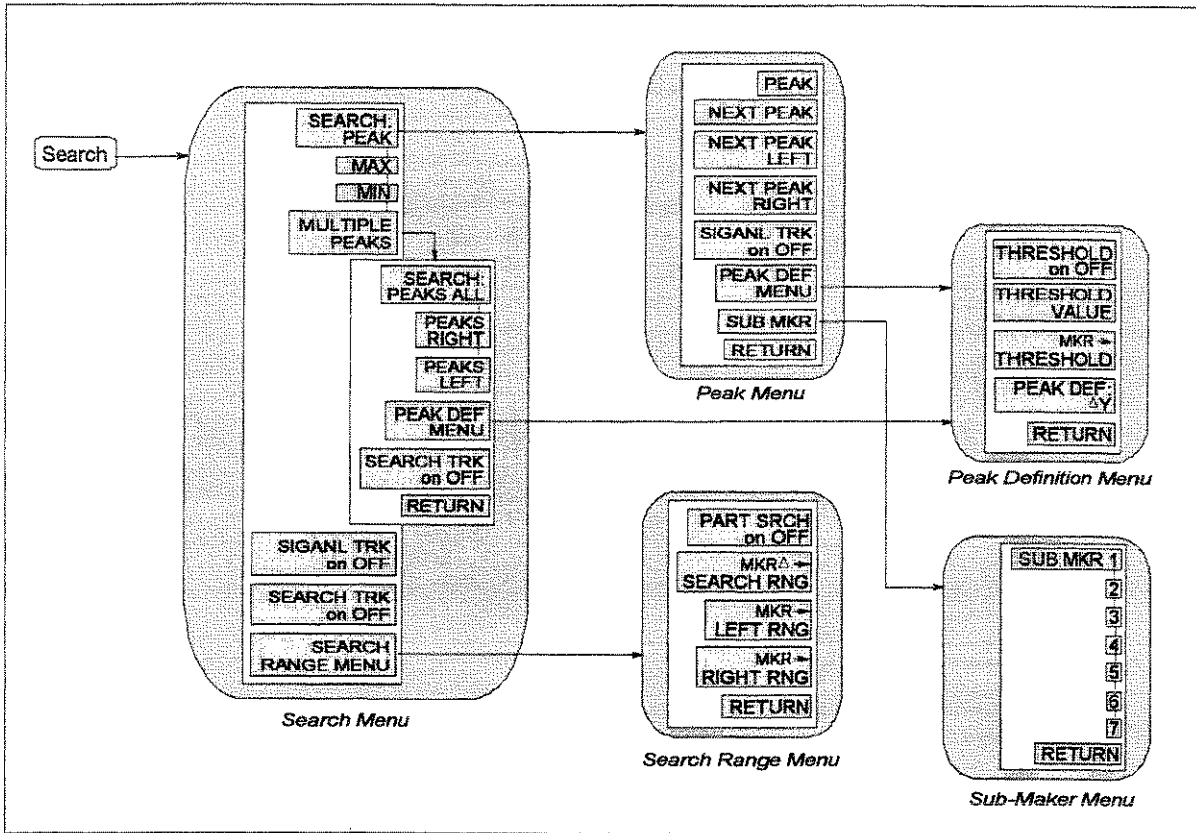

Figure B-20. Softkey Menus Accessed from the Marker → Key

Search



CB007018

Figure B-21. Softkey Menus Accessed from the **Search** Key for the Network Analyzer

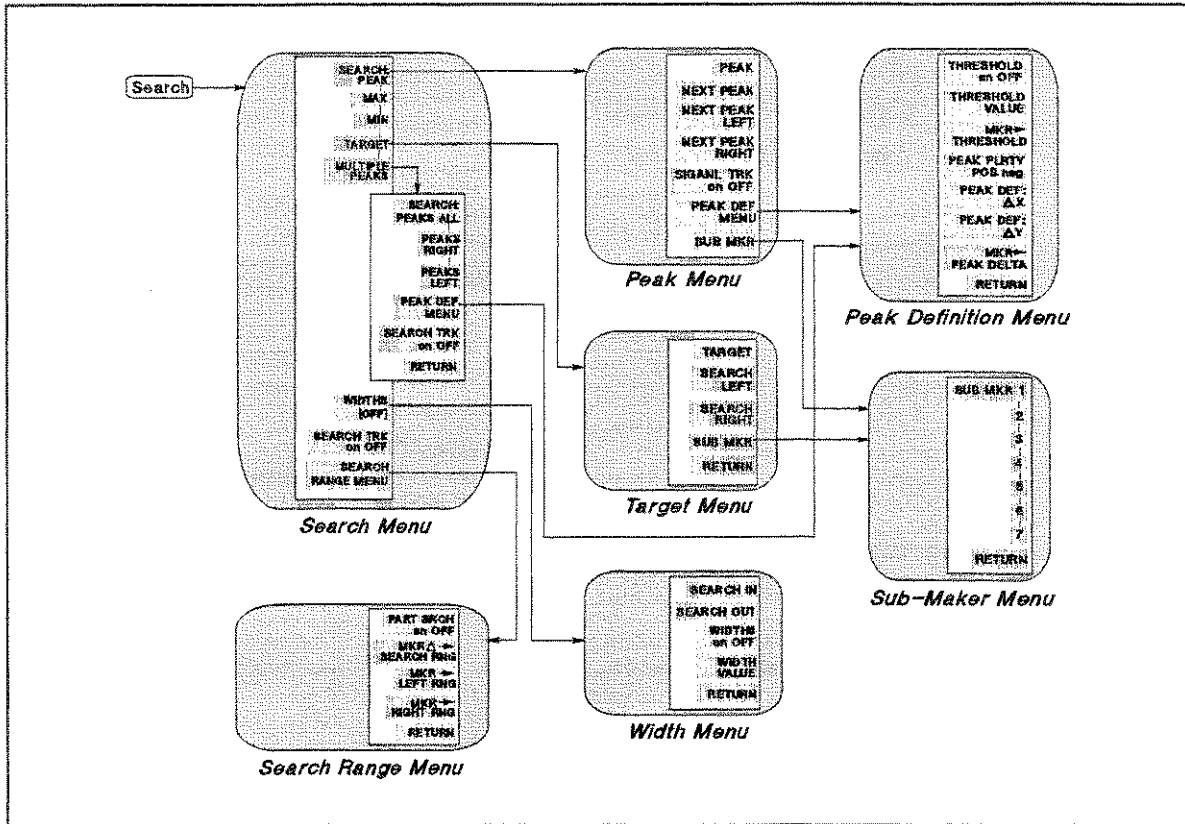

C5007016

Figure B-22. Softkey Menus Accessed from the **Search** Key for the Spectrum Analyzer

Utility

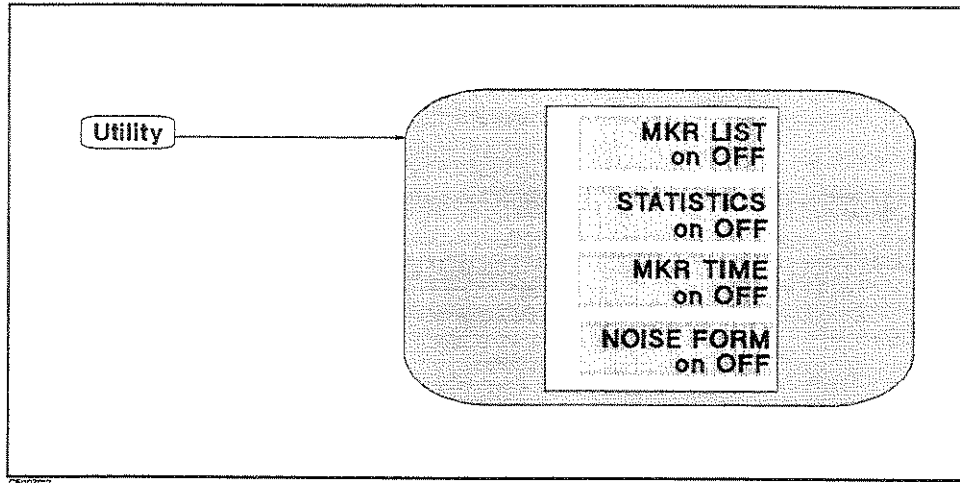

Figure B-23. Softkey Menus Accessed from the **Utility** Key for Spectrum Analyzer

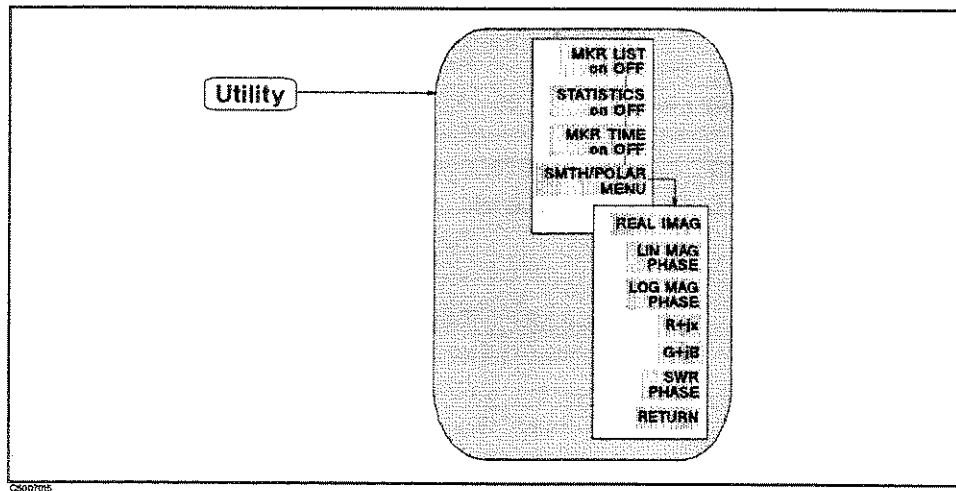

Figure B-24. Softkey Menus Accessed from the **Utility** Key for Network Analyzer

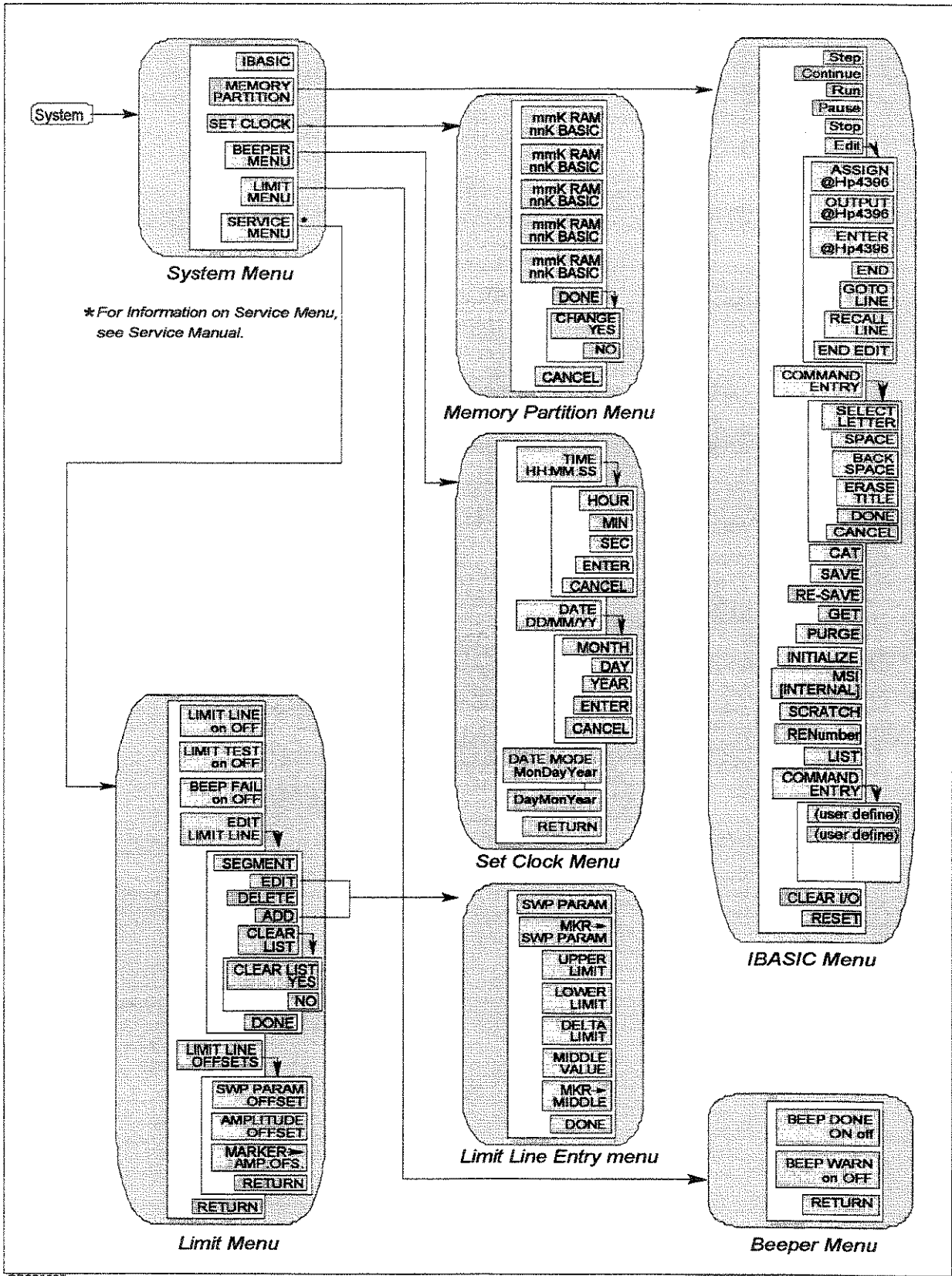

Figure B-25. Softkey Menus Accessed from the **System** Key

Local

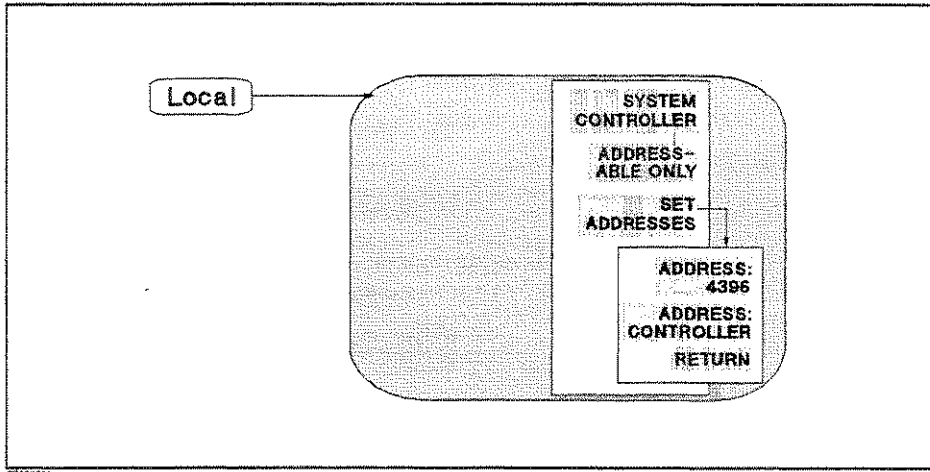
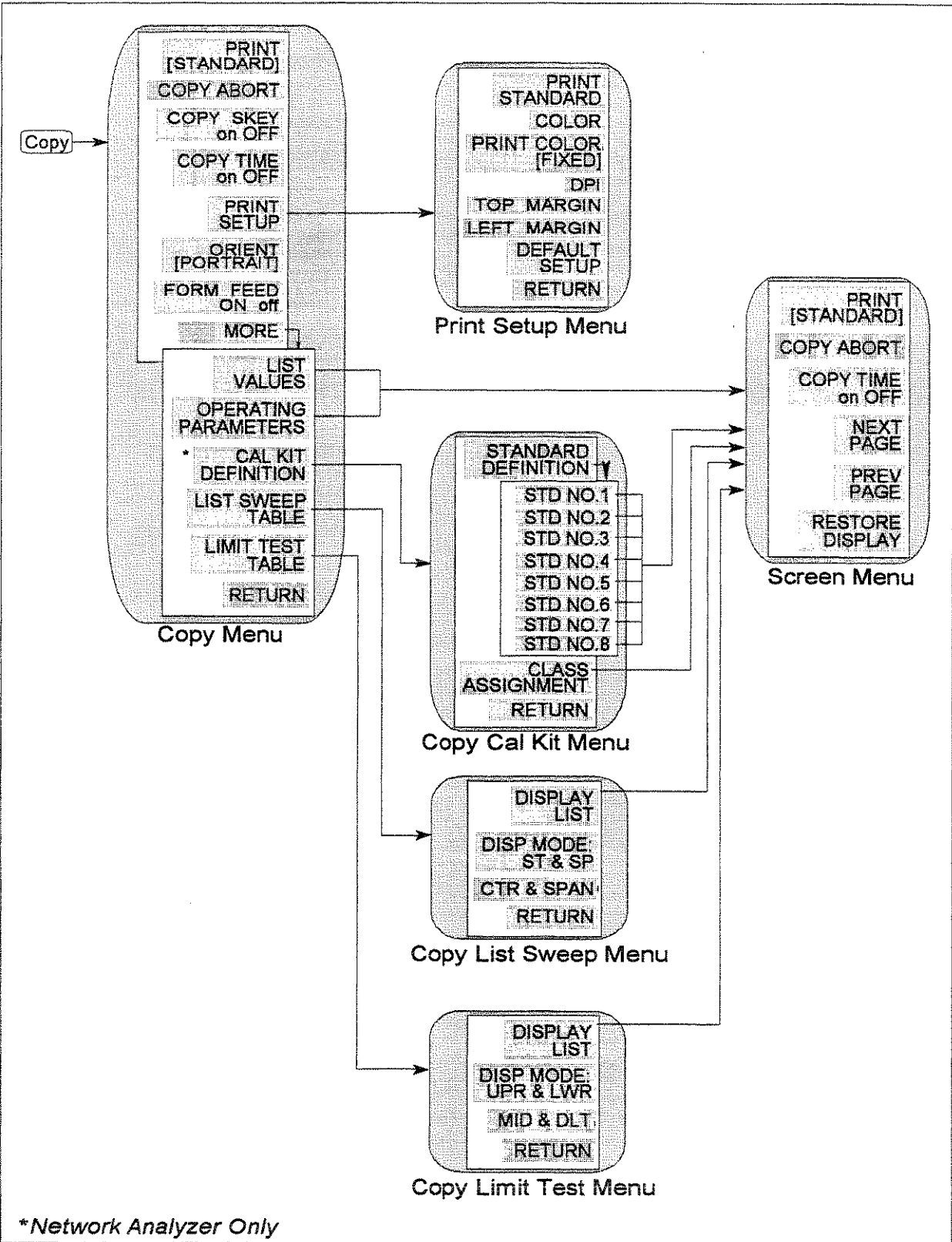

Figure B-26. Softkey Menus Accessed from the **Local** Key

Copy



*Network Analyzer Only

CB008038

Figure B-27. Softkey Menus Accessed from the Copy key

Save

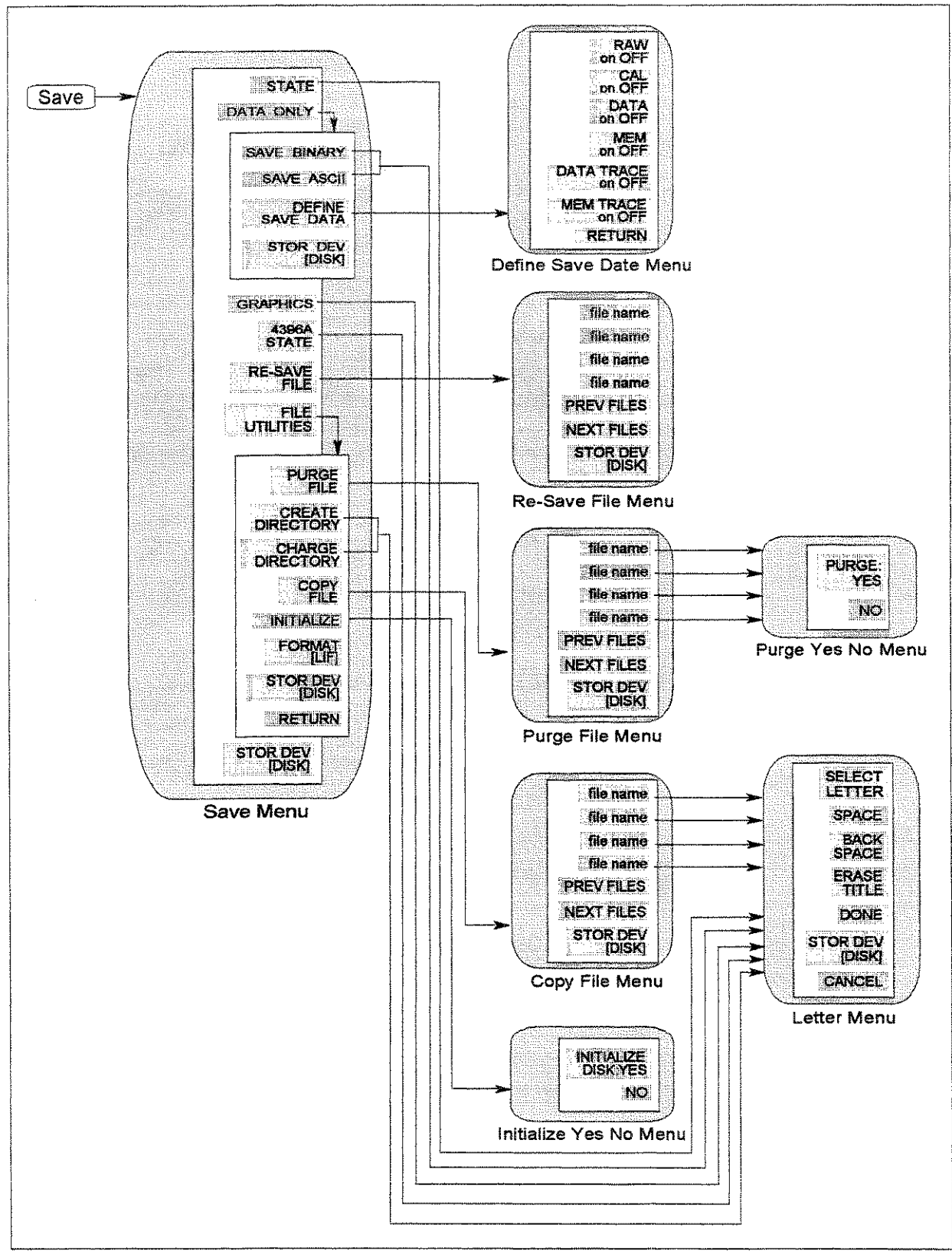

CB008036

Figure B-28. Softkey Menus Accessed from the **Save** Key

Recall

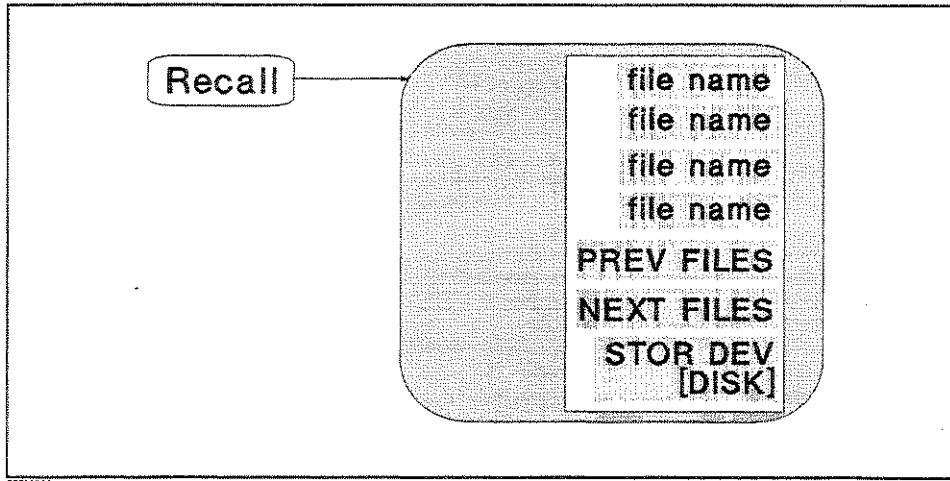

Figure B-29. Softkey Menus Accessed from the **Recall** Key

Saving and Recalling Instrument States and Data

This section describes storage devices, the save and recall functions, and the information you need to save instrument states and data into files.

Additional information on how to save and recall instrument states is provided in the *HP 4396B Task Reference*.

Note

The **Save** and **Recall** keys do not access Instrument BASIC programs. Instrument BASIC has its own menus (under the **System** key) for accessing the built-in disk drive and the RAM disk memory. See *Using HP Instrument BASIC with the HP 4396B* for detail.

Storage Devices

The analyzer supports two storage devices, a built-in flexible disk drive and a RAM disk memory. The flexible disk drive is suited to storing large numbers of files and long term data storage. RAM disk is suited to storing tentative data and instrument states and to store or get data quickly.

Note

Use the built-in flexible disk to store important data because the RAM disk data is lost when the power is turned off.

Disk Requirements

The analyzer's disk drive uses a 720 Kbyte , or 1.44 Mbyte 3.5 inch micro-flexible disk. See the "System accessories available" in Chapter 9 for disk part numbers.

Disk Formats

The analyzer's built-in disk drive can access both LIF (logical interchange format) and DOS formatted disks. The disk drive and the RAM disk memory can also initialize a new disk in either LIF or DOS format. Note that the analyzer can initialize 1.44 Mbyte disks only.

The following list shows the applicable DOS formats for the analyzer.

- 720 Kbyte, 80 tracks, double-sided, 9 sectors/track
- 1.44 Mbyte, 80 tracks, double-sided, 18 sectors/track

RAM Disk Memory Capacity

The RAM disk memory capacity is 512 Kbyte. The RAM disk memory capacity can be changed. This capacity includes the directory area. The capacity of data area depends on the disk format type.

Copy Files Between the RAM Disk and the Flexible Disk

A copy function is provided to copy files between the RAM disk and the flexible disk. **FILE UTILITIES** in the SAVE menu displays the softkeys used to copy files. The HP-IB command FILC is also available to copy files.

Note



When you copy files using this function, use the same disk format type for both the RAM disk and the flexible disk. This copy function cannot copy files when the format of the RAM disk is different from the format of the flexible disk.

File Types And Data Saved

Binary Files and ASCII Files

The analyzer supports two file formats, binary and ASCII, that are used to save data on a disk. Binary files are used to save measurement conditions and data using the SAVE function and to retrieve binary data using the RECALL function. External controllers and Instrument BASIC can read measurement data from binary data files. ASCII measurement data or screen image files can be read by commonly available IBM PC based software for data analysis or other secondary functions. The RECALL function cannot read ASCII files.

Note



When saving internal data arrays, note that ASCII data files cannot be recalled on the analyzer. If you need to recall the data, save the file in binary format. This binary data can be recalled and saved as an ASCII file at any time.

Data Groups

Instrument States and Internal Data Arrays (STATE)

This group consists of the instrument states that include raw calibration coefficients (network analyzer only), the data arrays, and the memory arrays. (Binary Files Only)

Internal Data Arrays (DATA ONLY)

The internal data arrays that are stored in the analyzer's memory consists of the following six data arrays. See "Data processing" in Chapter 12 for complete information on each data array and their relationships.(Binary and ASCII Files)

- *Raw data arrays* contain raw, uncalibrated measurement data.
- *Calibration Coefficients arrays* contain the expanded calibration coefficients obtained by calibration of the network analyzer.
- *Data arrays* contain the calibrated data obtained using the calibration coefficients.
- *Memory arrays* contain the memory data arrays obtained using the DATA→MEM operation.

- *Data Trace arrays* contain the formatted data.
- *Memory Trace arrays* contain the formatted data of the “memory arrays.”

These arrays can be saved selectively to suit the application. For example, when measuring several devices with the same measurement settings, you may need to save only the *trace arrays* for each device. Saving only the necessary arrays reduces the disk space required and the disk access time. In addition, saving internal data also allows the analysis of the measurement results using an external controller. See “File Structure of Internal Data Arrays File for Binary Files” for more information.

Graphics image (GRAPHICS)

The analyzer saves the graphics image of the screen as a graphics file in the TIFF (Tagged Image File Format) format. The TIFF format is used in a wide range of drawing software programs (in binary format only).

File Type and Data Group Combinations

You can select and save to a disk one of the following four combinations of the two file types and the four data groups.

- Binary File
 - Instrument states and internal data arrays (STATE)
 - Internal data arrays (DATA ONLY binary)
 - Graphics image (GRAPHICS)
- ASCII File
 - Internal data arrays (DATA ONLY ascii)

Note



DATA ONLY does not save instrument settings such as start and stop frequencies. BE CAREFUL! Always make sure that you save the existing STATE if you want to use the setup again.

File Names

All data saved using the built-in disk drive and the RAM disk memory has an identifying file name. A file name consists of the lower and upper case alphabet, numbers, and valid symbol characters. Up to 8 characters can be used for a file name. The following table shows the valid characters for LIF and DOS file names.

Table C-1. Valid Characters for File Names

Valid Characters		Description
LIF	DOS Format	
A - Z	A - Z	Upper case alphabet
a - z	a - z	Lower case alphabet
0 - 9	0 - 9	Numeric characters
-	\$ & # % ' ! () - _ @ ~ { } `	Symbol characters

One of the following suffixes or extensions is automatically added to the file name depending on the data group type stored in the file.

Table C-2. Suffixes and Extensions Added Automatically

Data Groups	Suffixes for LIF	Extensions for DOS
Instrument States and Internal Data Arrays (STATE)	_S	.STA
Internal Data Arrays (DATA ONLY (binary))	_D	.DTA
Internal Data Arrays as an ASCII File (DATA ONLY (ASCII))	_I	.TXT
Graphics Image as an TIFF File (GRAPHICS)	_T	.TIF

Auto Recall Function

When the analyzer is turned on, it looks for a file named "AUTOREC" from the built-in flexible disk, and if found, the analyzer automatically reads the file to retrieve its data.

Note



You must save AUTOREC file into the flexible disk and do not save it into the RAM disk memory because the RAM disk memory loses data when the power is turned off.

File Structure

File Structure of Internal Data Arrays File for Binary Files

Note Binary and ASCII file structures are not compatible.



When internal data arrays are saved as a binary file, the arrays' file consists of a file header at the top of the file and the data groups following the file header.

File Header

Every internal data array file begins with a file header. Figure C-1 shows the header structure.

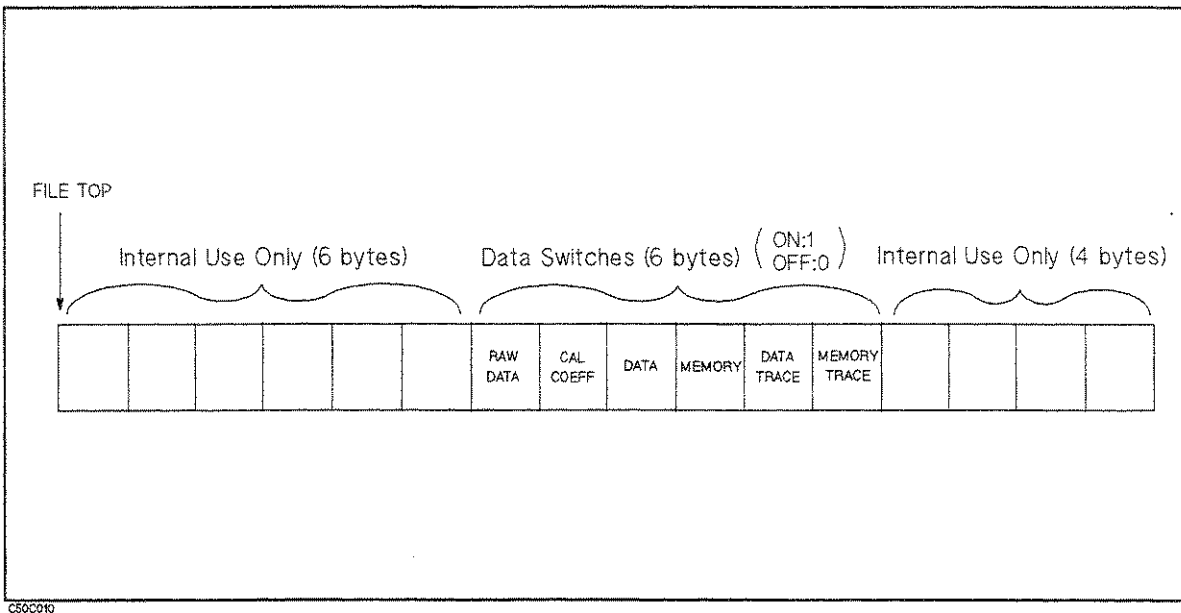

Figure C-1. File Header Structure

Six data switches define the data groups that follow the file head. Each one-byte switch is either 1 or 0 (decimal value) if the applicable data group exists or not, respectively. The data group to be followed is in the same order of these switches. For example, when the data switches, RAW DATA and DATA TRACE are 1 (ON), while the others are OFF, only the RAW DATA and DATA TRACE (in this order) groups will follow the header.

Data Group

Data group of each channel begins with a header and consists of the same structured data segments. The number of data segments depends on the data group type as follows:

- **RAW DATA** of the network analyzer consists of a header and four data segments per channel as shown in Figure C-2. They will follow the file header in this order:

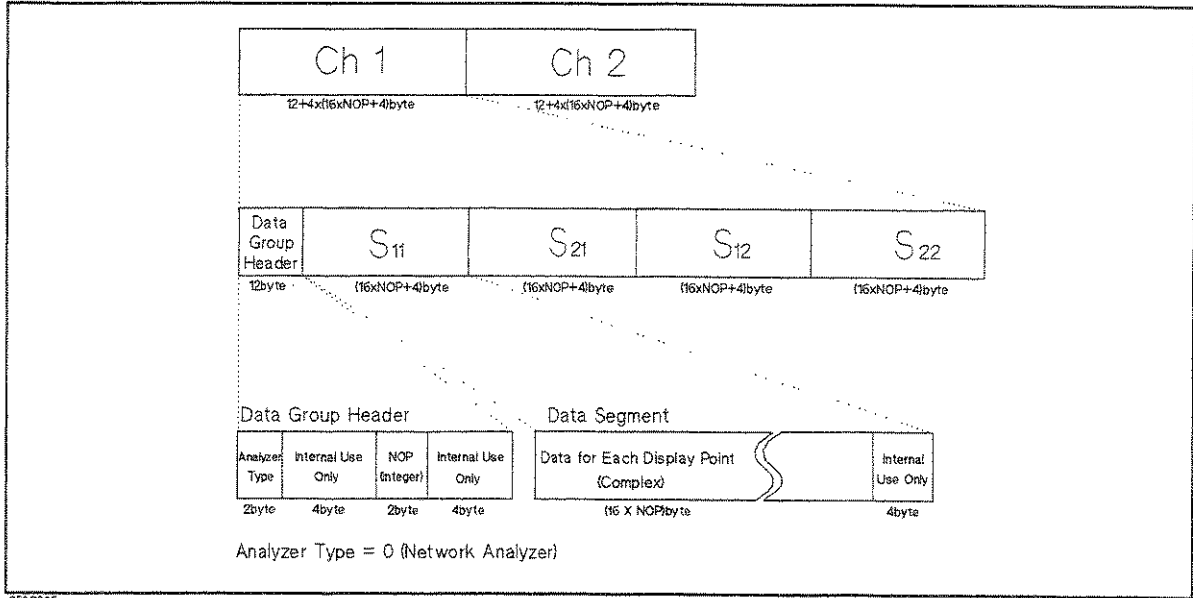

Figure C-2. RAW Data Group Structure for the Network Analyzer

- **RAW DATA** of the spectrum analyzer consists of a header and a data segment by a channel as shown in Figure C-3. They will follow the file header in this order:

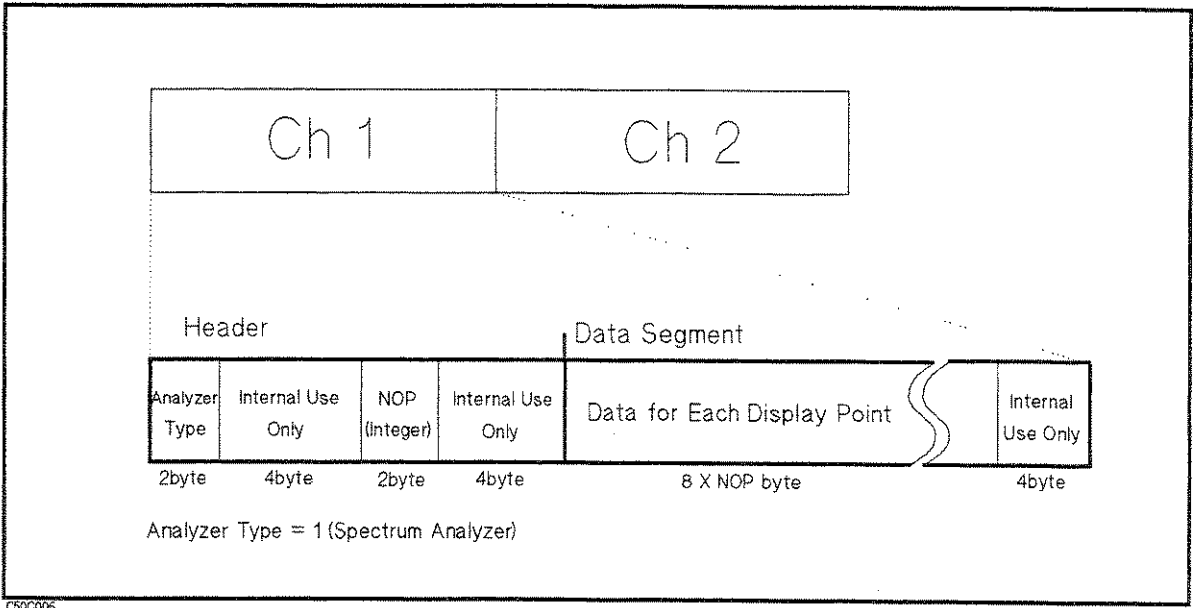
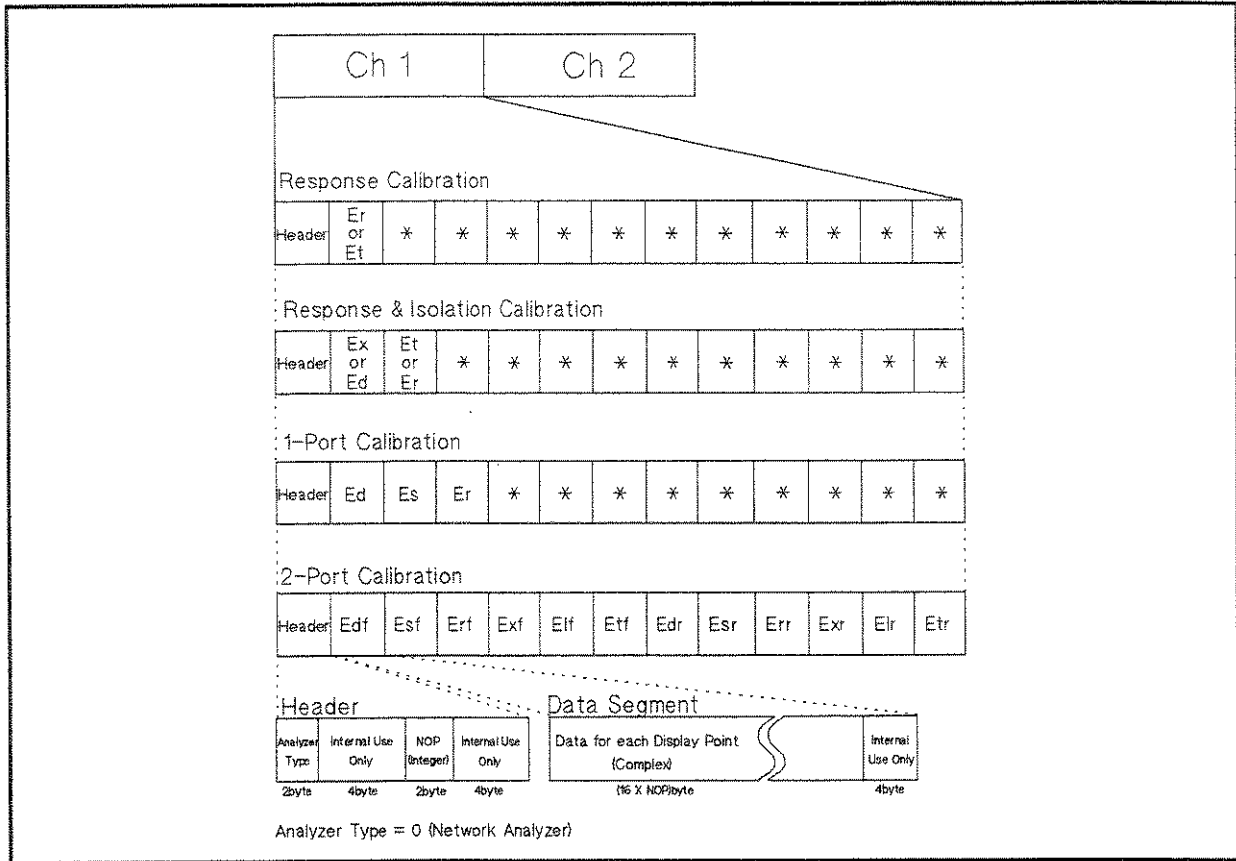

Figure C-3. RAW Data Group Structure for the Spectrum Analyzer

- **CAL** of the network analyzer consists of 12 data segments by a channel as shown in Figure C-4. The first half of the segments are for channel 1 and the second half of the segments are for channel 2. The contents of each segment depend on the type of calibration performed. (See "Cal" in Chapter 5.) CAL data is available for only the network analyzer.



CS0C007

Figure C-4. CAL Data Group Structure for the Network Analyzer

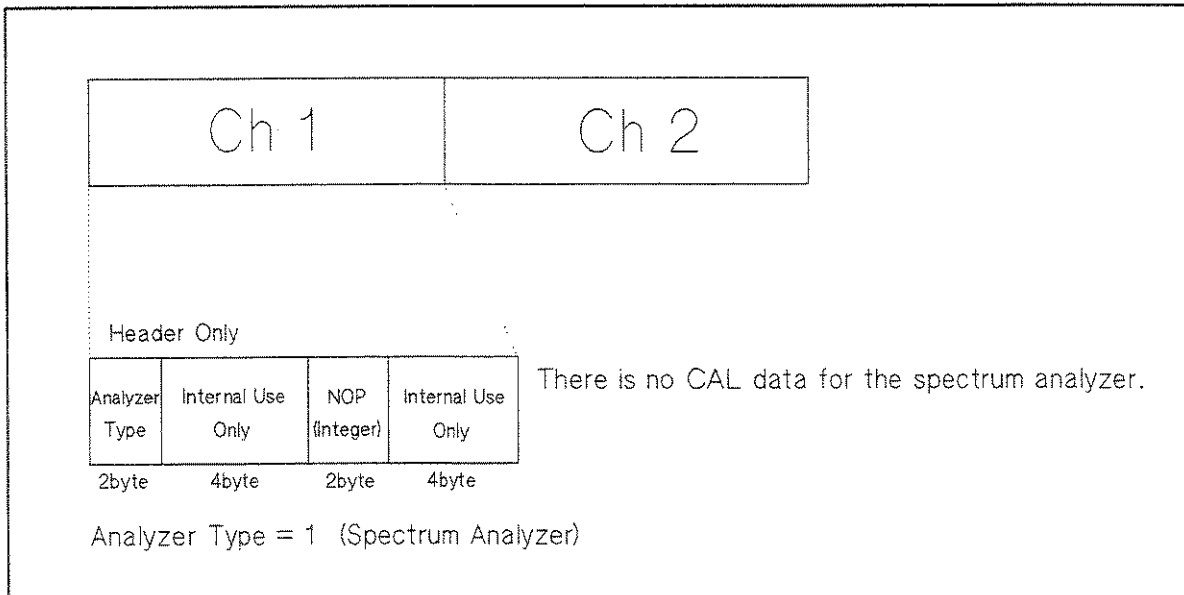

CS0C006

Figure C-5. CAL Data Group Structure for the Spectrum Analyzer

- **DATA** consists of a header and a data segment by a channel.
- **MEMORY** consists of a header and a data segment by a channel.
- **DATA TRACE** consists of a header and a data segment by a channel.

- **MEMORY TRACE** consists of a header and a data segment by a channel.

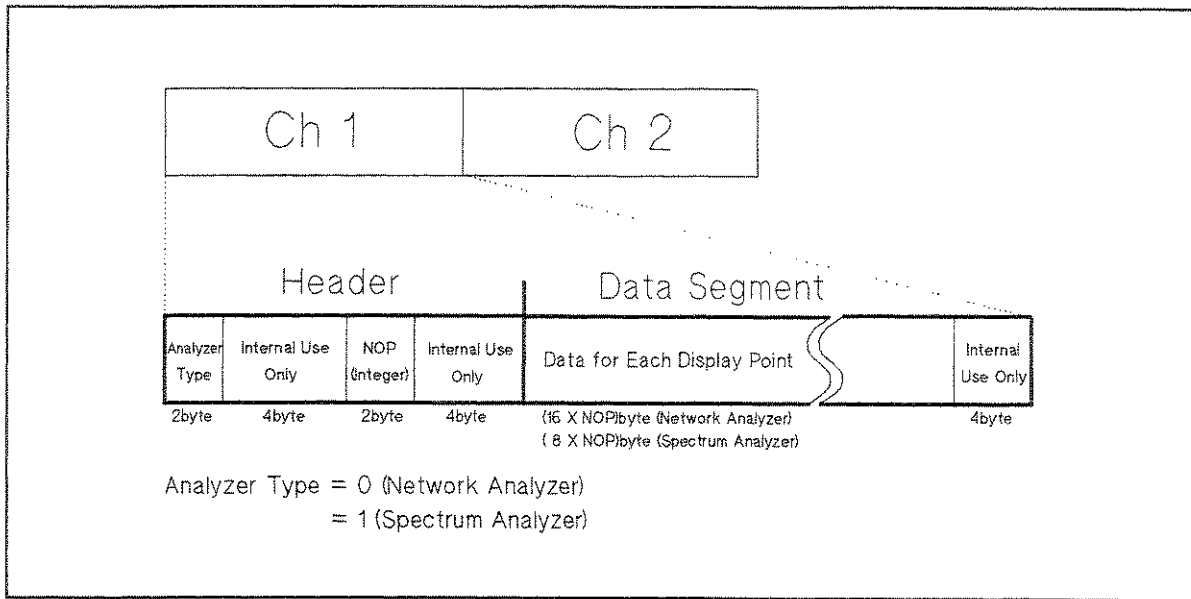

Figure C-6. DATA, MEMORY, DATA TRACE and MEMORY TRACE Data Group Structure

- **Analyzer Type** is a two-byte INTEGER value. This shows the analyzer type of each channel. "0" is set when the network analyzer is selected and "1" is set when the spectrum analyzer is selected.
- **Number Of Points (NOP)** is a two-byte INTEGER value. This number is equal to the number of complex or real data that follows the NOP.
- **DATA** is a set of the values for each measurement point. The values are IEEE 754 double precision floating number. When the network analyzer mode is selected, the values are two numbers (the first value is the real part, the second value is the imaginary part). The data size in bytes can be determined by $16 \times \text{NOP}$. When the spectrum analyzer mode is selected, the values are one number and the data size in bytes can be determined by $8 \times \text{NOP}$.

File Structure of Internal Data Arrays File for ASCII File

Numerical data and strings in an ASCII data file are separated by a tab, and a string is bound by double quotation marks.

Status Block and Data Block

An ASCII data file consists of a status block and data blocks. The status block consists of two lines, the revision number and the date code. The data block consists of three parts, the state part, the title line, and the data part.

■ State

The state part consists of the following instrument states:

- Channel number
- Title on the screen
- Measurement type
- Format type (and Unit)
- Number of points
- Sweep time
- Sweep type
- Source power or CW frequency
- IF, or RBW and VBW bandwidth

■ Title

The title part consists of the data array names saved. Data array names are described in the next section.

■ Data

The data part consists of sweep parameter and numerical data of data arrays.

Table C-3 shows an example of an ASCII data file.

Table C-3. Contents of ASCII Files

Block Names		Contents
Status Block		"4396A REV1.00" "DATE: mmm dd yyyy" ¹
Data Block	State	"CHANNEL: 1" "TITLE: This is a title." ² "MEAS TYPE: A/R" "FORMAT TYPE: LOG MAG" "NUMBER of POINTS: 201" "SWEEP TIME: 12.2 ms" "SWEEP TYPE: LIST FREQ" "SOURCE POWER: 0 dBm" ³ "BANDWIDTH: 4 kHz"
	Title	"Frequency"→"Raw [S11] Real"→"Raw [S11] Imag"→... ^{4,5}
	Data ^{6,7}	3.00000E+5→8.20007E-1→4.09729E-1→... ⁴ 1.52238E+7→9.32143E-1→-4.1914E-2→... : :

1 This is the date when the file is saved.

2 This line is listed when the title is defined (displayed).

3 Shows the power level of the source for a frequency sweep. If power sweep is selected, the CW frequency is listed (for example "CW FREQ: 100 MHz").

4 "→" means tab code. Data is separated by the tab code.

5 This line lists the names of the data array saved in this file. Titles used in the ASCII files are shown in Table C-4 through Table C-7.

6 Each line lists the measurement data at each measurement point. The number of lines in the data block is the same as the number of points.

7 In the network analyzer mode, complex data is saved. In the spectrum analyzer mode, only real data is saved.

File Structure for Single Channel and Dual Channel

If you save an ASCII file when DUAL CHANNEL is turned OFF, the ASCII data file consists of the active channel's data. If DUAL CHANNEL is turned ON, the ASCII data file consists of the data of both channels 1 and 2. The channel 2 data follows the channel 1 data as follows:

File Structures for Single and Dual Channels

Dual Channel OFF	Dual Channel ON
Status Block	Status Block
Data Block of Active Channel	Data Block of Channel 1
(end of file)	Status Block
	Data Block of Channel 2

Data Array Names for the Spectrum Analyzer

Data array names are used in the title line of the data block. Each data array of the spectrum analyzer has one name, Table C-4 lists all names.

Table C-4. Data Groups and Data Array Names for Spectrum Analyzer

Data Groups	Data Array Names	Descriptions
Raw Data	Raw	Raw data array.
Data	Data	Corrected Data arrays
Memory	Memory	Corrected Memory arrays
Data Trace	Data Trace	Data Trace arrays
Memory Trace	Memory Trace	Memory Trace arrays

Data Array Names for the Network Analyzer

Data array names are used in the title line of the data block. Each real and imaginary part of the internal data array of the network analyzer has one name, Table C-5 lists all names.

Table C-5.
Data Groups and Data Array Names for the Network Analyzer Mode

Data Groups	Data Array Names		Descriptions
	Real Part	Imaginary Part	
Raw Data	Raw[S11] Real	Raw[S11] Imag	Raw data arrays for S11 meas.
	Raw[S21] Real	Raw[S21] Imag	Raw data arrays for S21 meas.
	Raw[S12] Real	Raw[S12] Imag	Raw data arrays for S12 meas.
	Raw[S22] Imag	Raw[S22] Imag	Raw data arrays for S22 meas.
Calibration Data ¹	Cal[1] Real	Cal[1] Imag	Er, ² Et, ² Ex, ³ Ed, ^{3,4} or Edf ⁵
	Cal[2] Real	Cal[2] Imag	Et, ³ Er, ³ Es, ⁴ or Esr ⁵
	Cal[3] Real	Cal[3] Imag	Er ⁴ or Erf ⁵
	Cal[4] Real	Cal[4] Imag	Exr ⁵
	Cal[5] Real	Cal[5] Imag	Elf ⁵
	Cal[6] Real	Cal[6] Imag	Etf ⁵
	Cal[7] Real	Cal[7] Imag	Edr ⁵
	Cal[8] Real	Cal[8] Imag	Esr ⁵
	Cal[9] Real	Cal[9] Imag	Err ⁵
	Cal[10] Real	Cal[10] Imag	Exr ⁵
	Cal[11] Real	Cal[11] Imag	Elr ⁵
	Cal[12] Real	Cal[12] Imag	Etr ⁵
Data	Data Real	Data Imag	Corrected Data arrays
Memory	Memory Real	Memory Imag	Corrected Memory arrays
Data Trace	Data Trace Real	Data Trace Imag	Data Trace arrays
Memory Trace	Memory Trace Real	Memory Trace Imag	Memory Trace arrays

1 For more information on calibration, see "Calibration for Network Measurement" in Chapter 12. Calibration data is available for only network analyzer mode.

2 When response calibration is used.

3 When response and isolation calibration are used.

4 When 1 port calibration is used.

5 When 2 port calibration is used.

Data Groups of the Spectrum Analyzer

Every data group of the spectrum analyzer consists of one data array.

Data Groups of the Network Analyzer

Every data group of the network analyzer consists of data arrays. The number of data arrays depends on the data group types. The saved data arrays RAW and CAL depend on the instrument state.

- RAW DATA of the network analyzer consists of eight data arrays. The data arrays saved depend on the calibration type and the measurement type. If RAW DATA is saved in an ASCII data file when 2-port calibration is used, all eight RAW data arrays will be saved in the ASCII data file for any measurement type. If another calibration type is used, the data arrays saved depend on the measurement type. Table C-6 lists the RAW data array combinations that are saved for each measurement type selected.

Table C-6. Network Measurement Type Versus Raw Data Saved

Measurement Type	Raw Data Arrays Saved ¹
A/R	"Raw[S11] Real", "Raw[S11] Imag"
B/R	"Raw[S21] Real", "Raw[S21] Imag"
A/B	"Raw[S12] Real", "Raw[S12] Imag"
A	"Raw[S11] Real", "Raw[S11] Imag"
B	"Raw[S21] Real", "Raw[S21] Imag"
R	"Raw[S12] Real", "Raw[S12] Imag"
S11	"Raw[S11] Real", "Raw[S11] Imag"
S12	"Raw[S12] Real", "Raw[S12] Imag"
S21	"Raw[S21] Real", "Raw[S21] Imag"
S22	"Raw[S22] Real", "Raw[S22] Imag"

¹ When 2-port calibration is turned ON, all Raw Data is saved.

- CAL DATA of the network analyzer consists of twenty data arrays. The data arrays saved depend on the calibration type used. Table C-7 lists the CAL data arrays that are saved for each calibration type selected.

Table C-7. Calibration Type for Network Measurement Versus CAL Data Saved

Calibration Type	CAL Data Saved	Error Terms ¹
Response	"Cal[1] Real", "Cal[1] Imag"	Er or Et
Response and Isolation	"Cal[1] Real", "Cal[1] Imag" "Cal[2] Real", "Cal[2] Imag"	Ex or Ed Et or Er
1 port Calibration	"Cal[1] Real", "Cal[1] Imag" "Cal[2] Real", "Cal[2] Imag" "Cal[3] Real", "Cal[3] Imag"	Ed Es Er
2 port Calibration	"Cal[1] Real", "Cal[1] Imag" "Cal[2] Real", "Cal[2] Imag" "Cal[3] Real", "Cal[3] Imag" "Cal[4] Real", "Cal[4] Imag" "Cal[5] Real", "Cal[5] Imag" "Cal[6] Real", "Cal[6] Imag" "Cal[7] Real", "Cal[7] Imag" "Cal[8] Real", "Cal[8] Imag" "Cal[9] Real", "Cal[9] Imag" "Cal[10] Real", "Cal[10] Imag" "Cal[11] Real", "Cal[11] Imag" "Cal[12] Real", "Cal[12] Imag"	Edf Esf Erf Exf Elf Etf Edr Esr Err Exr Elr Etr

¹ For more information on error terms, refer to "Calibration for Network Measurement" in Chapter 12.

- DATA of the network analyzer consists of two data arrays.
- MEMORY of the network analyzer consists of two data arrays.
- DATA TRACE of the network analyzer consists of two data arrays.
- MEMORY TRACE of the network analyzer consists of two data arrays.

D

Input Range and Default Settings

When the **Preset** key is pressed, or the analyzer is turned ON, the analyzer reverts to a known state. There are subtle differences between the preset state and the power-up state.

Some power-up states are recalled from non-volatile memory (battery backup memory). If power to the non-volatile memory is lost, the analyzer will have certain parameters set to factory settings. "Results of Power Loss to Battery Backup Memory (Factory Setting)" lists the factory settings. The operating time of the battery backup memory is approximately 72 hours. The battery is automatically recharged while the instrument is ON. The recharge time (time required to fully recharge the battery) is approximately 10 minutes.

When line power is cycled the analyzer performs a self-test routine. Upon successful completion of the self-test routine, the instrument state is set to the following preset conditions. The same conditions are true following a "PRES" or "*RST" command over the HP-IB bus.

Active Channel Block

Chan 1 and **Chan 2**

Function	Range	Preset Value	Power ON default
Active Channel	Ch1, Ch2	Ch1	Ch1

Measurement Block

Meas

Function	Range	Preset Value	Power ON default
NA:Input Ports	B/R, A/R, R, A, B	Ch1:A/R, Ch2:B/R	Ch1:A/R, Ch2:B/R
NA:S-parameters	S_{11} , S_{21} , S_{12} , S_{22}	S_{11} ¹	Ch1: S_{11} , Ch2: S_{21} ¹
NA: Conversion	Off, Z:Ref, Z:Trans, Y:Ref, Y:Trans, 1/S, 4xphase, 8 xphase, 16xphase	Off	Off
Analyzer Type	Network, Spectrum	Analyzer type of the active channel before presetting ²	Analyzer type of the active channel when the power is turned OFF ²
SA:Detection	Positive, Negative, Sample	Positive	Positive

¹ When an S-parameter test set is connected to the analyzer.

² Both channel 1 and 2

Format

Function	Range	Preset Value	Power ON default
NA:Format	Log-mag, Phase, Delay, Smith, Polar, Lin-mag, SWR, Real, Imaginary, Expand phase, Admittance	Log-mag	Log-mag
SA: Format	Spectrum, Noise	Spectrum	Spectrum
SA: Unit	dBm, dBV, dB μ , V, Watt, Volt	dBm	dBm

Display

Function	Range	Preset Value	Power ON default
Dual Channel	On, Off	Off	Off
Display	Data, Memory, Data & Memory	Data	Data
Data Hold	Off, Max, Min	Off	Off
Data Math	Data, Data-Mem, Data+ Mem, Data/Mem,	Off	Off
Gain	± 100 to $\pm 1/1000$	1	1
Offset	± 500 k to ± 1 p	0	0
Aux Offset	± 500 , 5 digits	0	0
Display split	On, Off	On	On
Display Allocation	All Instrument, Half & Half, All BASIC, BASIC Status	No effect	No effect
Title	Max 53 characters	No effect	No title
Frequency Blank	On (can not be turn Off until presetting)	Off	Off
Intensity	0 to 100 %	No effect	83 %
Background Intensity	0 to 100 %	No effect	0 %
Ch1 Data color		No effect	Yellow
Ch1 Memory color		No effect	Green
Ch2 Data color		No effect	Cyan
Ch2 Memory color		No effect	Salmon Pink
Graticule color		No effect	Gray
Warning color		No effect	Red
Text color		No effect	White
IBASIC text color		No effect	Green
Pen 1 color		No effect	White
Pen 2 color		No effect	Red
Pen 3 color		No effect	Yellow
Pen 4 color		No effect	Green
Pen 5 color		No effect	Cyan
Pen 6 color		No effect	Modified Blue

Scale Ref

Function	Range	Preset Value	Power ON default
Scale / Div			
NA: Log mag	0.001 to 500	10	10
NA: Phase	10×10^{-3} to 500	90	90
NA: Delay	10×10^{-15} to 10	10×10^{-9}	10×10^{-9}
NA: Smith	10×10^{-12} to 10×10^3	1	1
NA: Polar	10×10^{-12} to 10×10^3	1	1
NA: LinMag	10×10^{-12} to 10×10^3	100×10^{-3}	100×10^{-3}
NA: SWR	10×10^{-12} to 10×10^3	1	1
NA: Real	10×10^{-12} to 10×10^3	200×10^{-3}	200×10^{-3}
NA: Imag	10×10^{-12} to 10×10^3	200×10^{-3}	200×10^{-3}
NA: ExpPhase	10×10^{-12} to 10×10^3	90	90
NA: Admit	10×10^{-12} to 10×10^3	1	1
SA: Unit dBm	0.1 to 20	10	10

Function	Range	Preset Value	Power ON default
Reference Value			
NA: LogMag	± 500	0	0
NA: Phase	$\pm 5 \times 10^6$	0	0
NA: Delay	$\pm 500 \times 10^{-3}$	0	0
NA: Smith	10×10^{-12} to 500	1	1
NA: Polar	10×10^{-12} to 500	1	1
NA: LinMag	$\pm 5 \times 10^6$	0	0
NA: SWR	$\pm 5 \times 10^6$	1	1
NA: Real	$\pm 5 \times 10^6$	0	0
NA: Imag	$\pm 5 \times 10^6$	0	0
NA: ExpPhase	$\pm 5 \times 10^6$	0	0
NA: Admit	10×10^{-12} to 500	1	1
SA: Unit dBm	-100 to +30	0	0

Function	Range	Preset Value	Power ON default
Reference Position			
NA: LogMag	0 to 10 with 0.01 resolution	5	5
NA: Phase	0 to 10 with 0.01 resolution	5	5
NA: Delay	0 to 10 with 0.01 resolution	5	5
NA: Smith	0 to 10 with 0.01 resolution	5	5
NA: Polar	0 to 10 with 0.01 resolution	5	5
NA: LinMag	0 to 10 with 0.01 resolution	0	0
NA: SWR	0 to 10 with 0.01 resolution	1	1
NA: Real	0 to 10 with 0.01 resolution	5	5
NA: Imag	0 to 10 with 0.01 resolution	5	5
NA: ExpPhase	0 to 10 with 0.01 resolution	5	5
NA: Admit	0 to 10 with 0.01 resolution	5	5
Spectrum	10 (fixed)	10	10
Noise	10 (fixed)	10	10

Function	Range	Preset Value	Power ON default
NA: Scale for	Data, Memory	Data	Data
NA: Scale Couple	On, Off	On	On
NA: Electrical delay	± 10 sec	0	0
NA: Phase offset	$\pm 360^\circ$	0	0
SA: Attenuator mode	Manual, Auto	Auto	Auto
SA: Attenuator at S input	0, 10, 20, 30, 40, 50, 60 dB	10 dB	10 dB
SA: Attenuator at R input	30 dB (fixed)	30 dB	30 dB
SA: Attenuator at A and B inputs	6 dB (fixed)	6 dB	6 dB
SA: Scale for	Data, Memory	Data	Data
SA: Scale Couple	On, Off	On	On
SA: Max. mixer level	-100 to -10 dBm with 10 dB resolution	-10.0	-10.0

Bw/Avg

Function	Range	Preset Value	Power ON default
NA: Band width	10, 30, 100, 300, 1 k, 3 k, 10 k, 40 kHz	3 kHz	3 kHz
NA: Averaging	On, Off	Off	Off
NA: Averaging factor	1 to 999	16	16
NA: Group delay aperture	0.25 to 20 % of span	1 %	1 %
SA: Band width	Auto, 1, 3, 10, 30, 100, 300, 1 k, 3 k, 10 k, 30 k, 100 k, 300 k, 1 M, 3 M	Auto (3 MHz)	Auto (3 MHz)
SA: Averaging	On, Off	Off	Off
SA: Averaging factor	1 to 999	16	16
SA: RBW/SPAN ratio	0.01 to 10 % of span	0.15 %	0.15 %
SA: Video Band Width	RBW, RBW/3, RBW/10, RBW/30, RBW/100, RBW/300	RBW	RBW

Cal

Function	Range	Preset Value	Power ON default
NA: Correction	On, OFF	Off	Off
NA: Calibration Type	None, Response, S11 1port, S22 1port, Full 2port, One path 2port	None	None
NA: Calibration Kit	7 mm, 3.5 mm, N50 Ω , N75 Ω , User kit	7 mm	7 mm
NA: System Impedance	1 m Ω to 5x10 ⁶	50	50
NA: Velocity factor	0.0 to 10.0 with 1.0x10 ⁻¹⁵ resolution	1	1
NA: Port1 extension	\pm 10 with 1.0x10 ⁻¹⁵ resolution	0	0
NA: Port2 extension	\pm 10 with 1.0x10 ⁻¹⁵ resolution	0	0
NA: Input R extension	\pm 10 with 1.0x10 ⁻¹⁵ resolution	0	0
NA: Input A extension	\pm 10 with 1.0x10 ⁻¹⁵ resolution	0	0
NA: Input B extension	\pm 10 with 1.0x10 ⁻¹⁵ resolution	0	0
SA: Correction	On, Off	Off	Off
SA: Input Z	50, 75	50	50

Sweep Block

Sweep

Function	Range	Preset Value	Power ON default
NA: Sweep time mode	Auto, Man	Auto	Auto
NA: NOP	2 to 801	201	201
NA: Coupled channel	On, Off	On	On
NA: Sweep type	Lin-Freq, Log-Freq, List-Freq, Power	Lin-Freq	Lin-Freq
NA: Frequency list		Empty	Empty
NA: List edit mode (sweep range)	Start-stop, Center-Span	Start-stop	Start-stop
NA: List edit mode (resolution)	NOP, Step size	NOP	NOP
SA: Sweep time mode	Auto, Man	Auto	Auto
SA: NOP for zero span ¹	2 to 801	801	801
SA: Frequency offset	±8 GHz with 1 mHz resolution	0	0
SA: Sweep type	Lin-Freq, Log-Freq, List-Freq	Lin-Freq	Lin-Freq
SA: Frequency list		Empty	Empty
SA: List edit mode	Start-stop, Center-Span	Start-stop	Start-stop

¹ NOP is automatically set and can not be changed by user, except for ZERO SPAN.

Source

Function	Range	Preset Value	Power ON default
NA: Power	-70 to +20 dBm with 0.1 dB resolution	0 dBm	0 dBm
NA: Slope	0 to 2 dB/GHz with 0.001 dB/GHz resolution	0	0
NA: Slope	On, Off	Off	Off
NA: Attenuator port 1	Depends on test set used	0	0
NA: Attenuator port 2	Depends on test set used	0	0
NA: CW frequency	100 kHz to 1.82 GHz	500 MHz	500 MHz
NA: Power Output	On Off	ON	ON
SA: Power	-70 to +20 dBm with 0.1 dB resolution	0 dBm	0 dBm
SA: Power OUT	On, Off	Off	Off

Trigger

Function	Range	Preset Value	Power ON default
Sweep type	Hold, Single, Number of groups, Continuous	Continuous	Continuous
Trigger Source	Free run, External, Manual, Video, Gate, HP-IB	Free run	Free run
Trigger event	On point, On sweep	On sweep	On sweep
Trigger polarity	Positive, Negative	Positive	Positive
Gate type	Level, Edge	level	Level
Gate delay	2.0 μ s to 3.2 s with 0.5 μ sec (minimum) resolution	10 μ s	10 μ sec
Gate length	2.0 μ s to 3.2 s with 0.5 μ sec resolution	10 μ s	10 μ sec
Video trigger level	0.0 to 100 % of span with 0.01 % resolution	50 %	50 %

Center

Function	Range	Preset Value	Power ON default
NA:Center Frequency	100 kHz to 1.8199999999 GHz	900.05 MHz	900.05 MHz
SA:Center Frequency	0 Hz to 1.819999999902 GHz	900 MHz	900 MHz
NA:Step Size mode	Auto, Man	Auto	Auto
SA:Step Size mode	Auto, Man	Man	Man
Center step size	0 to 1.8 GHz with 1 mHz resolution	1 MHz	1 MHz

Span

Function	Range	Preset Value	Power ON default
NA: Span Frequency	0 to 1.8199 GHz with 1 mHz resolution	1.7999 GHz	1.7999 GHz
NA: Span power	0 to 30 dB	30 dB	30 dB
SA: Span Frequency	0 to 1.8 GHz with 1 mHz resolution	1.8 GHz	1.8 GHz

Start and **Stop**

Function	Range	Preset Value	Power ON default
SA: Start Frequency	0 Hz to 1.82 GHz with 1 mHz resolution	0 Hz	0 Hz
NA: Start Frequency	0 Hz to 1.82 GHz with 1 mHz resolution	100 kHz	100 kHz
Stop Frequency	0 kHz to 1.82 GHz with 1 mHz resolution	1.8 GHz	1.8 GHz
NA: Start power	-70 to +20 dBm with 0.1 dBm resolution	-60 dBm	-60 dBm
NA: Stop power	-70 to +20 dBm with 0.1 dBm resolution	-30 dBm	-30 dBm

Marker Block

Marker

Function	Range	Preset Value	Power ON default
Marker position	START to STOP	CENTER ¹	CENTER ¹
Number of Marker	1	Off	Off
Number of Sub-marker	7	All OFF	All OFF
Delta-marker	Δmarker, FixedΔmarker	Off	Off
Marker on	Data, Memory	Data	Data
Marker coupled	On, Off	Off	Off
NA: Marker mode	Cont, Disc	Cont	Cont
NA: FixedΔmkr position(Sweep prmtr)	START to STOP	START	START
NA: FixedΔmkr position(Value)	The same as the reference value	(0)	(0)
NA: FixedΔmkr position(AUX value)	The same as the reference value	(0)	(0)
SA: FixedΔmkr position(Sweep prmtr)	The same as the reference value	(0)	(0)
SA: FixedΔmkr position(Value)	The same as the reference value	(0)	(0)

¹ Zero will be returned if the marker position is read using HP-IB command after presetting and before the marker turn to ON.

Marker→

Function	Range	Preset Value	Power ON default
Destination channel	Ch1, Ch2	Ch1	Ch1
Zooming aperture	0.01 to 50 % of SPAN	10 %	10 %

Search

Function	Range	Preset Value	Power ON default
Search range	START to STOP	Full SPAN	Full SPAN
NA: Peak polarity	Positive, Negative	Positive	Positive
NA: Width	On, Off	Off	Off
NA: Width value	±500 dB	-3 dB	-3dB
Signal track	On, Off	Off	Off
NA: Peak def:ΔX	±50 GHz	1 MHz	1 MHz
NA: Peak def:ΔY	Depends on format	1 dB	1 dB
NA: Peak def:ΔY	Depends on format	15 dB	15 dB
Threshold	On, Off	Off	Off
NA: Threshold value	The same as the reference value	-100 dB	- 100 dB
SA: Threshold value	The same as the reference value	- 100 dBm	- 100 dBm
Part search	On, Off	Off	Off

Utility

Function	Range	Preset Value	Power ON default
NA: Marker list	On, Off	Off	Off
NA: Statistics	On, Off	Off	Off
NA: Marker time	On, Off	Off	Off
SA: Marker list	On, Off	Off	Off
SA: Statistics	On, Off	Off	Off
SA: Marker time	On, Off	Off	Off
SA: Noise form	On, Off	Off	Off

Instrument State Block

System

Function	Range	Preset Value	Power ON default
Clock time	0:0:0 to 24:59:59	No effect	No effect
Clock date	Maximu 2099	No effect	No effect
Date format	MonDayYear, DayMonYear	MonDayYear	MonDayYear
Beeper done	On, Off	On	On
Beeper warning	On, Off	Off	Off
Limit Line	On, Off	Off	Off
Limit test	On, Off	Off	Off
Beep Fail	On, Off	Off	Off
Limit line table		No effect	Empty
Limit line offset (Sweep prmr)	±1.9 GHz	0	0
Limit line offset (Amp)	±50000	0	0

Copy

Function	Range	Preset Value	Power ON default
Print mode	Standard, Color	Standard	Standard
Copy time	On, Off	Off	Off
Print color	Fixed, Variable	Fixed	Fixed
Limit table list	UPR & LWR, MID & DLT	UPR & LWR	UPR & LWR
List table list (sweep prmr)	ST & SP, STR & SPN	ST & SP	ST & SP
List table list (points)	NOP, Step size	NOP	NOP

Save

Function	Range	Preset Value	Power ON default
Initialize disk format	LIF, DOS	LIF	LIF
Graphics extension	3 characters	.TIF	.TIF
ASCII data extension	3 characters	.TXT	.TXT
Define Save:Raw	On, Off	Off	Off
Define Save:Cal	On, Off	Off	Off
Define Save:Data	On, Off	Off	Off
Define Save:Mem	On, Off	Off	Off
Define Save:Trace data	On, Off	On	On
Define Save:Trace mem	On, Off	On	On

Local

Function	Range	Preset Value	Power ON default
HP-IB address	0 to 30	No effect	No effect
HP-IB mode	System controller, Addressable	No effect	No effect

Results of Power Loss to Battery Backup Memory (Factory Setting)

Function	Factory Setting
HP-IB address for HP 4396A	17
HP-IB address for controller	21
Calibration kit definitions	Factory set default (See the following tables)
Real time clock date	12/06/1992
Analyser type	Network Analyzer mode

Predefined Calibration Kits

Table D-1. 3.5 mm Standard Cal Kit

NO.	STANDARD TYPE	C0 $\times 10^{-15}F$	C1 $\times 10^{-27}F/Hz$	C2 $\times 10^{-36}F/Hz^2$	OFFSET DELAY ps	OFFSET LOSS GΩ/s	OFFSET Z_0 Ω	STANDARD LABEL
1	SHORT				16.695	1.3	50	SHORT
2	OPEN	53	150	0	14.491	1.3	50	OPEN
3	LOAD				0	1.3	50	BROADBAND
4	DELAY/THRU				0	1.3	50	THRU
5	LOAD				0	1.3	50	SLIDING
6	LOAD				0	1.3	50	LOWBAND
7	SHORT				0	1.3	50	SHORT
8	OPEN	79.4	0	40	0	1.3	50	OPEN

Table D-2. 7 mm Standard Cal Kit

NO.	STANDARD TYPE	C0 $\times 10^{-15}F$	C1 $\times 10^{-27}F/Hz$	C2 $\times 10^{-36}F/Hz^2$	OFFSET DELAY ps	OFFSET LOSS MΩ/s	OFFSET Z_0 Ω	STANDARD LABEL
1	SHORT				0	700	50	SHORT
2	OPEN	92.85	0	7.2	0	700	50	OPEN
3	LOAD				0	700	50	BROADBAND
4	DELAY/THRU				0	700	50	THRU
5	LOAD				0	700	50	SLIDING
6	LOAD				0	700	50	LOWBAND
7	SHORT				0	700	50	
8	OPEN	79.4	0	40	0	700	50	OPEN

Table D-3. 50 Ω Type-N Standard Cal Kit

NO.	STANDARD TYPE	C0 $\times 10^{-15}F$	C1 $\times 10^{-27}F/Hz$	C2 $\times 10^{-36}F/Hz^2$	OFFSET DELAY ps	OFFSET LOSS MΩ/s	OFFSET Z_0 Ω	STANDARD LABEL
1	SHORT				0	700	50	SHORT[M]
2	OPEN	108	55	130	0	700	50	OPEN[M]
3	LOAD				0	700	50	BROADBAND
4	DELAY/THRU				0	700	50	THRU
5	LOAD				0	700	50	SLIDING
6	LOAD				0	700	50	LOWBAND
7	SHORT				17.544	700	50	SHORT[F]
8	OPEN	62	17	28	17.544	700	50	OPEN[F]

Table D-4. 75 Ω Type-N Standard Cal Kit

NO.	STANDARD TYPE	C0 $\times 10^{-15}F$	C1 $\times 10^{-27}F/Hz$	C2 $\times 10^{-36}F/Hz^2$	OFFSET DELAY ps	OFFSET LOSS M Ω/s	OFFSET Z ₀ Ω	STANDARD LABEL
1	SHORT				0	1.13×10^3	75	SHORT[M]
2	OPEN	63.5	84	56	0	1.13×10^3	75	OPEN[M]
3	LOAD				0	1.13×10^3	75	BROADBAND
4	DELAY/THRU				0	1.13×10^3	75	THRU
5	LOAD				0	1.13×10^3	75	SLIDING
6	LOAD				0	1.13×10^3	75	LOWBAND
7	SHORT				17.544	1.13×10^3	75	SHORT[F]
8	OPEN	41	40	5	17.544	1.13×10^3	75	OPEN[F]

Predefined Standard Class Assignments

Table D-5. Standard Class Assignments Table (7 mm and 3.5 mm)

CLASS	A	B	C	D	E	F	G	STANDARD CLASS LABEL
S _{11A}	2							OPEN
S _{11B}	1							SHORT
S _{11C}	3							LOAD
S _{22A}	2							OPEN
S _{22B}	1							SHORT
S _{22C}	3							LOAD
Forward Transmission	4							THRU
Reverse Transmission	4							THRU
Forward Match	4							THRU
Reverse Match	4							THRU
Response	1	2	4					RESPONSE
Response & Isolation	1	2	4					RESPONSE

Table D-6. Standard Class Assignments Table (50 Ω Type-N)

CLASS	A	B	C	D	E	F	G	STANDARD CLASS LABEL
S _{11A}	2	8						OPENS
S _{11B}	1	7						SHORTS
S _{11C}	3							LOAD
S _{22A}	2	8						OPENS
S _{22B}	1	7						SHORTS
S _{22C}	3							LOAD
Forward Transmission	4							THRU
Reverse Transmission	4							THRU
Forward Match	4							THRU
Reverse Match	4							THRU
Response	1	7	2	8	4			RESPONSE
Response & Isolation	1	7	2	8	4			RESPONSE

Table D-7. Standard Class Assignments Table (75 Ω Type-N)

CLASS	A	B	C	D	E	F	G	STANDARD CLASS LABEL
S _{11A}	2	8						OPENS
S _{11B}	1	7						SHORTS
S _{11C}	3							LOAD
S _{22A}	2	8						OPENS
S _{22B}	1	7						SHORTS
S _{22C}	3							LOAD
Forward Transmission	4							THRU
Reverse Transmission	4							THRU
Forward Match	4							THRU
Reverse Match	4							THRU
Response	1	7	2	8	4			RESPONSE
Response & Isolation	1	7	2	8	4			RESPONSE

Error Messages

This section lists the error messages that are displayed on the analyzer display or transmitted by the instrument over HP-IB. Each error message is accompanied by an explanation, and suggestions are provided to help in solving the problem. Where applicable, references are provided to the related chapter of the appropriate manual.

When displayed, error messages are preceded with the word "CAUTION:." That part of the error message has been omitted here for the sake of brevity. Some messages without the "CAUTION:" are for information only, and do not indicate an error condition. The messages are listed first in alphabetical order because the displayed messages do not contain the message number. The messages are then listed in numerical order to make them easier to find if they are read over the HP-IB.

In addition to error messages, The analyzer's status is indicated by status notations in the left margin of the display. Examples are *, Cor, and P↓. Sometimes these appear together with error messages. A complete listing of status notations and their meanings is provided in Chapter 2 of this manual.

Error Messages in Alphabetical Order

10 ADDITIONAL STANDARDS NEEDED

Error correction for the selected calibration class cannot be computed until all the necessary standards have been measured.

84 ANALYZER TYPE MISMATCH

The analyzer receives a command that is not available for the current analyzer type. Please confirm HP-IB command or change analyzer type before sending the command.

17 BACKUP DATA LOST

Data checksum error on the battery backup memory has occurred. The battery is recharged for approximately 10 minutes after power was turned ON.

-160 Block data error

This error, as well as errors -161 and -168, are generated when analyzing the syntax of a block data element. This particular error message is used if the analyzer cannot detect a more specific error.

-168 Block data not allowed

A legal block data element was encountered but was not allowed by the analyzer at this point in parsing.

13 **CALIBRATION ABORTED**

The calibration in progress was terminated due to a change of the active channel or stimulus parameters.

11 **CALIBRATION REQUIRED**

No valid calibration coefficients were found when you attempted to turn calibration ON. See *Task Reference* for information on how to perform calibration.

126 **CAN'T CHANGE NUMBER OF POINTS**

The number of points of the spectrum analyzer mode cannot be to change manually, except in zero span.

133 **CAN'T CHANGE ON LIST SWEEP**

When list sweep is selected, the following parameters are not allowed to be changed:

- CENTER, SPAN, START, STOP
- NOP
- IFBW or RBW
- POWER

Modify the list table to change these parameters in the list sweep.

99 **CAN'T CHANGE WHILE DUAL CHAN OFF**

The Cross channel cannot be turned on when dual channel is off. Turn on the dual channel before the cross channel is turned on.

82 **CAN'T CHANGE- ANOTHER CONTROLLER ON BUS**

The analyzer cannot assume the mode of system controller until the active controller is removed from the bus or relinquishes the bus. See Chapter 7 of the *Programming Guide*.

134 **CAN'T COUPLE IN CURRENT INPUTS**

When one channel measures a ratio measurement, and the other one measures an absolute measurement (for example: A/R and B), **COUPLED CH** can not be turned on.

114 **CAN'T SAVE GRAPHICS WHEN COPY IN PROGRESS**

If you attempt to save graphics when a print is in progress, this error message is displayed.

1 **CAN'T SET RBW AUTO IN ZERO SPAN**

The RBW AUTO mode cannot be selected in the zero span. The RBW must be specified manually in the zero span. See "Bandwidth menu Spectrum Analyzer" in Chapter 5 (spectrum analyzer mode only).

125 **CAN'T SET SLOPE ON IN POWER SWEEP**

The slope function can be turned on in frequency sweep.

127 CAN'T SET SWEEP TIME AUTO IN ZERO SPAN

The automatic sweep time cannot be in zero span of the spectrum analyzer mode. (The network analyzer mode allows that the automatic sweep time is turned on.)

-281 Cannot create program

Indicates that an attempt to create a program was unsuccessful. A reason for the failure might include not enough memory.

-140 Character data error

This error, as well as errors -141 through -148, are generated when analyzing the syntax of a character data element. This particular error message is used if the analyzer cannot detect a more specific error.

-148 Character data not allowed

A legal character data element was encountered where prohibited by the analyzer.

-144 Character data too long

The character data element contains more than twelve characters (see IEEE 488.2, 7.7.1.4).

-100 Command error

This is a generic syntax error that the analyzer cannot detect more specific errors. This code indicates only that a command error, as defined in IEEE 488.2, 11.5.1.1.4, has occurred.

-110 Command header error

An error was detected in the header. This error message is used when the analyzer cannot detect the more specific errors described for errors -111 through -119.

75 COMMAND IGNORED - SEGMENT NOT DONE YET

The HP-IB command the analyzer received is ignored, because the segment is editing (*HP-IB only*). Send LIMSDON (limit segment done) or SDON (segment done) to terminate editing segment. (See *HP-IB Command Reference*.)

50 CONT SWITCHING MAY DAMAGE MECH SWITCH

RF output power switch or input attenuator switch at input S is switching sweep by sweep, because RF power level or the input attenuator setting is different between two channels and the dual channel is turn on. To avoid premature wearing out of the output power switch and input attenuator switch, change trigger type to HOLD, SINGLE, or NUMBER of GROUP to hold sweep after measurement required. Or turn off the dual channel, or set the power level and the input attenuator of both channels to the same setting.

132 COUPLED CHAN - BETWEEN NA & NA ONLY

The analyzer types of both channels must be the network analyzer mode when the coupled channel is turned on.

74 CURRENT EDITING SEGMENT SCRATCHED

The current editing segment for the list table and the limit line is scratched when the following cases occur (*HP-IB only*) :

- When EDITLIST (edit list table) command is received while editing a segment for the list table.
- When EDITLIML (edit limit line) command is received while editing a segment for the limit line.

Send LIMSDON (limit segment done) or SDON (segment done) to terminate editing segment.

16 CURRENT PARAMETER NOT IN CAL SET

HP-IB only. Correction is not valid for the selected measurement parameter.

-230 Data corrupt or stale

Possibly invalid data. New reading started but not completed since last access.

-225 Data out of memory

The analyzer has insufficient memory to perform the requested operation.

-222 Data out of range

A legal program data element was parsed but could not be executed because the interpreted value was outside the legal range as defined by the analyzer (see IEEE 488.2, 11.5.1.1.5).

-231 Data questionable

Indicates that measurement accuracy is suspect.

-104 Data type error

The parser recognized an unallowed data element. For example, numeric or string data was expected but block data was encountered.

117 DUPLICATE FILE EXTENSION

The extension name entered is already used for other file types. Use other extension name.

15 EXCEEDED 7 STANDARDS PER CLASS

A maximum of seven standards can be defined for any class. See "Modifying Calibration Kits" in the *Function Reference*.

-200 Execution error

This is the generic syntax error that the analyzer cannot detect more specific errors. This code indicates only that an execution error as defined in IEEE 488.2, 11.5.1.1.5 has occurred.

-123 Exponent too large

The magnitude of the exponent was larger than 32000 (see IEEE 488.2, 7.7.2.4.1).

-257 File name error

Indicates that a legal program command or query could not be executed because the file name on the device media was in error. For example, an attempt was made to copy to a duplicate file name. The definition of what constitutes a file name error is device-specific.

-256 File name not found

A legal program command could not be executed because the file name on the device media was not found: for example, an attempt was made to read or copy a nonexistent file.

83 FORMAT NOT VALID FOR MEASUREMENT

The conversion function except the 1/S and the multiple phase modes is not valid for the Smith, admittance, and SWR formats.

131 FREQUENCY SWEEP ONLY

The sweep type must be frequency sweep when the center step size is set.

-105 GET not allowed

A Group Execute Trigger (GET) was received within a program message (see IEEE 488.2, 7.7).

-240 Hardware error

Indicates that a legal program command or query could not be executed because of a hardware problem in the analyzer. Definition of what constitutes a hardware problem is completely device-specific. This error message is used when the analyzer cannot detect the more specific errors described for errors -241 through -249.

-241 Hardware missing

A legal program command or query could not be executed because of missing analyzer hardware. For example, an option was not installed.

-111 Header separator error

A character that is not a legal header separator was encountered while parsing the header. For example, no white space followed the header, thus *SRE4 is an error.

-114 Header Suffix out of range

The value of a numeric suffix attached to a program mnemonic makes the header invalid.

-224 Illegal parameter value

Used where exact value, from a list of possibilities, was expected.

-282 Illegal program name

The name used to reference a program was invalid. For example, redefining an existing program, deleting a nonexistent program, or in general, referencing a nonexistent program.

-283 Illegal variable name

An attempt was made to reference a nonexistent variable in a program.

-213 Init ignored

A request for a measurement initiation was ignored as another measurement was already in progress.

141 **INSUFFICIENT MEMORY**

If a lot of tasks is executed at same time, memory might be insufficient for a while. (For example, running HP Instrument BASIC program, printing a screen, and sending or receiving data array by HP-IB are required at same time.) Please wait until finishing some tasks then execute the next task.

–161 **Invalid block data**

A block data element was expected, but was invalid for some reason (see IEEE 488.2, 7.7.6.2). For example, an END message was received before the length was satisfied.

–141 **Invalid character data**

Either the character data element contains an invalid character or the particular element received is not valid for the header.

–121 **Invalid character in number**

An invalid character for the data type being parsed was encountered. For example, an alpha character in a decimal numeric or a “9” in octal data.

–101 **Invalid character**

A syntax element contains a character that is invalid for that type. For example, a header containing an ampersand (SENSE&).

154 **INVALID DATE**

The date entered to set the real time clock is invalid. Reenter correct date.

112 **INVALID FILE NAME**

HP-IB only. The file name for the RECALL, PURGE, or RE-SAVE function must have a “_D” or “_S” extension for LIF format.

–103 **Invalid separator**

The parser was expecting a separator and encountered an illegal character. For example, the semicolon was omitted after a program message unit, *RST:TRIG.

–151 **Invalid string data**

A string data element was expected, but was invalid for some reason (see IEEE 488.2, 7.7.5.2). For example, an END message was received before the terminal quote character.

–131 **Invalid suffix**

The suffix does not follow the syntax described in IEEE 488.2, 7.7.3.2, or the suffix is inappropriate for the analyzer.

115 **LIF-DOS COPY NOT ALLOWED**

If you try to copy a file between the RAM disk and the flexible disk when the format of the RAM disk is different from the format of the flexible disk, this message is displayed.

124 LIST TABLE EMPTY OR INSUFFICIENT TABLE

The frequency list is empty. To implement the list frequency mode, add segments to the list table.

-250 Mass storage error

Indicates that a mass storage error occurred. This error message is used when the analyzer cannot detect the more specific errors described for errors -257.

51 MEASUREMENT INVALID AT $f \leq 1\text{MHz}$, $\text{IFBW} \geq 10\text{kHz}$

This message will displayed when whole frequency measured is less than or equal to 1 MHz and IFBW is set to 10 kHz or 40 kHz because the network measurement performance is not warranted at frequency ≤ 1 MHz with 10 kHz or 40 kHz IFBW.

-311 Memory error

An error was detected in the analyzer's memory.

-109 Missing parameter

Fewer parameters were received than required for the header. For example, the *SRE command requires one parameter, so receiving only *SRE is not allowed.

98 NO ACTIVE MARKER

The marker→ command cannot be execute when no marker is displayed on the screen. Turn on the marker before executing the marker→ commands.

12 NO CALIBRATION CURRENTLY IN PROGRESS

The **RESUME CAL SEQUENCE** softkey is not valid unless a calibration is in progress. Start a new calibration. See "**Cal** key" in the *Function Reference*.

119 NO DATA TRACE DISPLAYED

The **SCALE FOR [DATA]** is selected when the data trace is not displayed.

93 NO DATA TRACE

The **MARKER ON [DATA]** is selected when the data trace is not displayed.

+0 No error

The error queue is empty. Every error in the queue has been read (OUTPERRO? query) or the queue was cleared by power-on or the *CLS command.

100 NO FIXED DELTA MARKER

The **FIXED AMKR VALUE** and **FIXED AMKR AUX VALUE** softkey requires that fixed delta marker is turned on.

96 **NO MARKER DELTA - RANGE NOT SET**

The **MKRA→SEARCH RNG** softkey requires that delta marker is turned ON.

95 **NO MARKER DELTA - SPAN NOT SET**

The **MKRA→SPAN** softkey requires that delta marker mode be turned ON.

120 **NO MEMORY TRACE DISPLAYED**

The **SCALE FOR [MEMORY]** is selected when the memory trace is not displayed.

94 **NO MEMORY TRACE**

The **MARKER ON [MEMORY]** is selected when the memory trace is not displayed.

113 **NO STATE/DATA FILES ON DISK**

There are no files on the flexible disk with extensions, “_D” or “_S” for LIF format, or “STA” or “.DTA” for DOS format.

116 **NO STATE/DATA FILES ON MEMORY**

There are no files on the RAM disk memory with extensions, “_D” or “_S” for LIF format, or “.STA” or “.DTA” for DOS format.

34 **NO VALID MEMORY TRACE**

If a memory trace is to be displayed or otherwise used, a data trace must first be stored to memory.

18 **NOT ALLOWED IN LIST SWEEP**

The level cal cannot be executed in the list sweep. The sweep type must be the linear frequency (spectrum analyzer mode only). See “Calibration menu Spectrum Analyzer” in Chapter 5.

55 **NOT ENOUGH DATA**

The amount of data sent to the analyzer is less than that expected (*HP-IB only*).

14 **NOT VALID FOR PRESENT TEST SET**

The calibration requested is inconsistent with the test set present. This message occurs in the following situations:

- A full 2-port calibration is requested with a test set other than an S-parameter test set.
- A one-path 2-port calibration is requested with an S-parameter test set (this procedure is typically used with a transmission/reflection test set).

-120 **Numeric data error**

This error, as well as errors -121 through -129, are generated when parsing a data element that appears to be numeric, including the nondecimal numeric types. This particular error message is used if the analyzer cannot detect a more specific error.

-128 Numeric data not allowed

A legal numeric data element was received, but the analyzer does not accept it in this position for a header.

146 ON POINT NOT ALLOWD FOR THE CURRENT TRIG

The trigger event mode cannot be changed to the ON POINT mode because the current trigger source setting does not allow the ON POINT mode. The trigger event ON POINT mode is available for only MANUAL, EXTERNAL, and BUS trigger sources of the network analyzer mode.

56 OPTION NOT INSTALLED

This error occurs when an HP-IB command which is optional command is sent and the analyzer is not installed the option (*HP-IB only*). Please confirm options installed to the analyzer using *OPT? command (see *HP-IB Command Reference*.)

45 OVERLOAD ON INPUT A**44 OVERLOAD ON INPUT B****46 OVERLOAD ON INPUT R****47 OVERLOAD ON INPUT S**

The power level at one of the four receiver inputs exceeds a certain level greater than the maximum input level.

-220 Parameter error

Indicates that a program data element related error occurred. This error message is used when the analyzer cannot detect the more specific errors described for errors -221 through -229.

-108 Parameter not allowed

More parameters were received than expected for the header. For example, the *SRE command only accepts one parameter, so receiving *SRE 4, 16 is not allowed.

48 PHASE LOCK LOOP UNLOCKED

Sever error. Contact your nearest Hewlett-Packard office.

49 POWER FAILED ON *nnn*

Sever error. Contact your nearest Hewlett-Packard office. One or more power is failed. *nnn* is one of -5 V, -15 V, +5 V, +15 V, +65 V, and PostRegHot. It shows that which power line is failed. When this error occurs, the system halts so a controller cannot read this error by HP-IB.

26 PRINTER: not on, not connected, out of paper

The printer does not respond to control. Check the supply to the printer, online status, sheets, and so on.

-284 Program currently running

Certain operations dealing with programs may be illegal while the program is running. For example, deleting a running program might not be possible.

-280 Program error

Indicates that a downloaded program-related execution error occurred. This error message is used when the analyzer cannot detect the more specific errors described for errors -281 through -289.

-112 Program mnemonic too long

The header contains more than twelve characters (see IEEE 488.2, 7.6.1.4.1).

-286 Program runtime error

A program runtime error of the HP Instrument BASIC has occurred. To get a more specific error information, use the ERRM\$ or ERRN command of the HP Instrument BASIC.

-285 Program syntax error

Indicates that a syntax error appears in a downloaded program. The syntax used when parsing the downloaded program is device-specific.

-430 Query DEADLOCKED

A condition causing a deadlocked query error occurred (see IEEE 488.2, 6.3.1.7). For example, both input buffer and output buffer are full and the analyzer cannot continue.

-400 Query errors

This is the generic query error that the analyzer cannot detect more specific errors. This code indicates only that a query error as defined in IEEE 488.2, 11.5.1.1.7 and 6.3 has occurred.

-410 Query INTERRUPTED

A condition causing an interrupted query error occurred (see IEEE 488.2, 6.3.2.3). For example, a query followed by DAB or GET before a response was completely sent.

-420 Query UNTERMINATED

A condition causing an unterminated query error occurred (see IEEE 488.2, 6.3.2.2). For example, the analyzer was addressed to talk and an incomplete program message was received by the controller.

-350 Queue overflow

A specific code entered into the queue in lieu of the code that caused the error. This code indicates that there is no room in the queue and an error occurred but was not recorded.

111 RECALL ERROR: INSTR STATE PRESET

A serious error, for example corrupted data, is detected on recalling a file, and this forced the analyzer to be PRESET.

129 LIN FREQ ONLY

The repetitive sampling is turn on when span must be zero, the sweep type must be linear frequency, and the trigger source must be EXT or VIDEO only. Confirm the analyzer setting and set appropriate setting for the repetitive sampling mode.

128 SPAN = 0 ONLY

The repetitive sampling is turn on when span must be zero, the sweep type must be linear frequency, and the trigger source must be EXT or VIDEO only. Confirm the analyzer setting and set appropriate setting for the repetitive sampling mode.

130 TRIG = EXT or VIDEO ONLY

The repetitive sampling is turn on when span must be zero, the sweep type must be linear frequency, and the trigger source must be EXT or VIDEO only. Confirm the analyzer setting and set appropriate setting for the repetitive sampling mode.

110 SAVE ERROR

A serious error, for example physically damaged disk surface, is detected on saving a file.

76 SEGMENT START/STOP OVERLAPPED

Segments are not allowed to be overlapped. Reenter appropriate value for start or stop value of segments to avoid that segment is not overlapped.

-330 Self-test failed

A self-test failed. Contact your nearest Hewlett-Packard office or see the *Service Manual* for troubleshooting.

-221 Settings conflict

A legal program data element was parsed but could not be executed due to the current device state (see IEEE 488.2, 6.4.5.3 and 11.5.1.1.5).

-150 String data error

This error, as well as errors -151 and -158, are generated when analyzing the syntax of a string data element. This particular error message is used if the analyzer cannot detect a more specific error.

-158 String data not allowed

A string data element was encountered but was not allowed by the analyzer at this point in parsing.

-130 Suffix error

This error, as well as errors -131 through -139, are generated when parsing a suffix. This particular error message is used if the analyzer cannot detect a more specific error.

-138 Suffix not allowed

A suffix was encountered after a numeric element that does not allow suffixes.

-134 Suffix too long

The suffix contained more than 12 characters (see IEEE 488.2, 7.7.3.4).

-102 Syntax error

An unrecognized command or data type was encountered. For example, a string was received when the analyzer was not expecting to receive a string.

-310 System error

Some error, termed "system error" by the analyzer, has occurred.

-124 Too many digits

The mantissa of a decimal numeric data element contains more than 255 digits excluding leading zeros (see IEEE 488.2, 7.7.2.4.1).

77 TOO MANY SEGMENTS OR POINTS

Frequency list mode is limited to 31 segments or 801 points.

64 TOO MANY SEGMENTS

The maximum number of segments for the limit line table is 18. See Chapter 8 of the *HP 4396B Task Reference*.

-223 Too much data

A legal program data element of block, expression, or string type was received that contained more data than the analyzer could handle due to memory or related device-specific requirements.

54 TOO MUCH DATA

Either there is too much binary data to send to the analyzer when the data transfer format is FORM 2, FORM 3 or FORM 5, or the amount of data is greater than the number of points.

78 TOO SMALL POINTS OR TOO LARGE STOP

STOP+SPAN/(NOP-1) is out of sweep range. Increase NOP or change STOP value to lower frequency to avoid this error.

-210 Trigger error

A trigger related error occurred. This error message is used when the analyzer cannot detect the more specific errors described for errors -211 through -219.

-211 Trigger ignored

A GET, *TRG, or triggering signal was received and recognized by the analyzer but was ignored because of analyzer timing considerations. For example, the analyzer was not ready to respond.

-113 Undefined header

The header is syntactically correct, but it is undefined for the analyzer. For example, *XYZ is not defined for the analyzer.

19 UNEXPECTED DATA DETECTED: CAL ABORTED

The signal measured for the level cal is not adequate for the calibration signal. (spectrum analyzer mode only.) See "Calibration menu Spectrum Analyzer" in Chapter 5.

Error Messages in Numerical Order

+0 No error

The error queue is empty. Every error in the queue has been read (OUTPERRO? query) or the queue was cleared by power-on or the *CLS command.

1 CAN'T SET RBW AUTO IN ZERO SPAN

The RBW AUTO mode cannot be selected in the zero span. The RBW must be specified manually in the zero span. See "Bandwidth menu Spectrum Analyzer" in Chapter 5 (spectrum analyzer mode only).

10 ADDITIONAL STANDARDS NEEDED

Error correction for the selected calibration class cannot be computed until all the necessary standards have been measured.

11 CALIBRATION REQUIRED

No valid calibration coefficients were found when you attempted to turn calibration ON. See *Task Reference* for information on how to perform calibration.

12 NO CALIBRATION CURRENTLY IN PROGRESS

The **RESUME CAL SEQUENCE** softkey is not valid unless a calibration is in progress. Start a new calibration. See "[Cal] key" in the *Function Reference*.

13 CALIBRATION ABORTED

The calibration in progress was terminated due to a change of the active channel or stimulus parameters.

14 NOT VALID FOR PRESENT TEST SET

The calibration requested is inconsistent with the test set present. This message occurs in the following situations:

- A full 2-port calibration is requested with a test set other than an S-parameter test set.
- A one-path 2-port calibration is requested with an S-parameter test set (this procedure is typically used with a transmission/reflection test set).

15 EXCEEDED 7 STANDARDS PER CLASS

A maximum of seven standards can be defined for any class. See "Modifying Calibration Kits" in the *Function Reference*.

16 **CURRENT PARAMETER NOT IN CAL SET**

HP-IB only. Correction is not valid for the selected measurement parameter.

17 **BACKUP DATA LOST**

Data checksum error on the battery backup memory has occurred. The battery is recharged for approximately 10 minutes after power was turned on.

18 **NOT ALLOWED IN LIST SWEEP**

The level cal cannot be executed in the list sweep. The sweep type must be the linear frequency (spectrum analyzer mode only). See "Calibration menu Spectrum Analyzer" in Chapter 5.

19 **UNEXPECTED DATA DETECTED: CAL ABORTED**

The signal measured for the level cal is not adequate for the calibration signal. (spectrum analyzer mode only.) See "Calibration menu Spectrum Analyzer" in Chapter 5.

26 **PRINTER: not on, not connect, wrong address**

The printer does not respond to control. Check the supply to the printer, online status, sheets, and so on.

34 **NO VALID MEMORY TRACE**

If a memory trace is to be displayed or otherwise used, a data trace must first be stored to memory.

44 **OVERLOAD ON INPUT B**

45 **OVERLOAD ON INPUT A**

46 **OVERLOAD ON INPUT R**

47 **OVERLOAD ON INPUT S**

The power level at one of the four receiver inputs exceeds a certain level greater than the maximum input level.

48 **PHASE LOCK LOOP UNLOCKED**

Sever error. Contact your nearest Hewlett-Packard office.

49 **POWER FAILED ON *nnn***

Sever error. Contact your nearest Hewlett-Packard office. One or more power is failed. *nnn* is one of -5 V, -15 V, +5 V, +15 V, +65 V, and PostRegHot. It shows that which power line is failed. When this error occurs, the system halts so a controller cannot read this error by HP-IB.

50 CONT SWITCHING MAY DAMAGE MECH SWITCH

RF output power switch or input attenuator switch at input S is switching sweep by sweep, because RF power level or the input attenuator setting is different between two channels and the dual channel is turn on. To avoid premature wearing out of the output power switch and input attenuator switch, change trigger type to HOLD, SINGLE, or NUMBER of GROUP to hold sweep after measurement required. Or turn off the dual channel, or set the power level and the input attenuator of both channels to the same setting.

51 MEASUREMENT INVALID AT $f \leq 1\text{MHz}$, $\text{IFBW} \geq 10\text{KHz}$

This message will displayed when whole frequency measured is less than or equal to 1 MHz and IFBW is set to 10 kHz or 40 kHz because the network measurement performance is not warranted at frequency ≤ 1 MHz with 10 kHz or 40 kHz IFBW.

54 TOO MUCH DATA

Either there is too much binary data to send to the analyzer when the data transfer format is FORM 2, FORM 3 or FORM 5, or the amount of data is greater than the number of points.

55 NOT ENOUGH DATA

The amount of data sent to the analyzer is less than that expected (*HP-IB only*).

56 OPTION NOT INSTALLED

This error occurs when an HP-IB command which is optional command is sent and the analyzer is not installed the option (*HP-IB only*). Please confirm options installed to the analyzer using *OPT? command (see *HP-IB Command Reference*.)

64 TOO MANY SEGMENTS

The maximum number of segments for the limit line table is 18. See Chapter 8 of the *HP 4396B Task Reference*.

74 CURRENT EDITING SEGMENT SCRATCHED

The current editing segment for the list table and the limit line is scratched when the following cases occur (*HP-IB only*) :

- When EDITLIST (edit list table) command is received while editing a segment for the list table.
- When EDITLIML (edit limit line) command is received while editing a segment for the limit line.

Send LIMSDON (limit segment done) or SDON (segment done) to terminate editing segment.

75 COMMAND IGNORED - SEGMENT NOT DONE YET

The HP-IB command the analyzer received is ignored, because the segment is editing (*HP-IB only*). Send LIMSDON (limit segment done) or SDON (segment done) to terminate editing segment. (See *HP-IB Command Reference*.)

76 SEGMENT START/STOP OVERLAPPED

Segments are not allowed to be overlapped. Reenter appropriate value for start or stop value of segments to avoid that segment is not overlapped.

77 TOO MANY SEGMENTS OR POINTS

Frequency list mode is limited to 31 segments or 801 points.

78 TOO SMALL POINTS OR TOO LARGE STOP

STOP+SPAN/(NOP-1) is out of sweep range. Increase NOP or change STOP value to lower frequency to avoid this error.

82 CAN'T CHANGE- ANOTHER CONTROLLER ON BUS

The analyzer cannot assume the mode of system controller until the active controller is removed from the bus or relinquishes the bus. See Chapter 7 of the *Programming Guide*.

83 FORMAT NOT VALID FOR MEASUREMENT

The conversion function except the 1/S and the multiple phase modes is not valid for the Smith, admittance, and SWR formats.

84 ANALYZER TYPE MISMATCH

The analyzer receives a command that is not available for the current analyzer type. Please confirm HP-IB command or change analyzer type before sending the command.

93 NO DATA TRACE

The **MARKER ON [DATA]** is selected when the data trace is not displayed.

94 NO MEMORY TRACE

The **MARKER ON [MEMORY]** is selected when the memory trace is not displayed.

95 NO MARKER DELTA - SPAN NOT SET

The **MKRA→SPAN** softkey requires that delta marker mode be turned ON.

96 NO MARKER DELTA - RANGE NOT SET

The **MKRA→SEARCH RNG** softkey requires that delta marker is turned ON.

98 NO ACTIVE MARKER

The marker→ command cannot be execute when no marker is displayed on the screen. Turn on the marker before executing the marker→ commands.

99 CAN'T CHANGE WHILE DUAL CHAN OFF

The Cross channel cannot be turned on when dual channel is off. Turn on the dual channel before the cross channel is turned on.

100 NO FIXED DELTA MARKER

The **FIXED AMKR VALUE** and **FIXED AMKR AUX VALUE** softkey requires that fixed delta marker is turned on.

110 SAVE ERROR

A serious error, for example physically damaged disk surface, is detected on saving a file.

111 RECALL ERROR: INSTR STATE PRESET

A serious error, for example corrupted data, is detected on recalling a file, and this forced the analyzer to be PRESET.

112 INVALID FILE NAME

HP-IB only. The file name for the RECALL, PURGE, or RE-SAVE function must have a "_D" or "_S" extension for LIF format.

113 NO STATE/DATA FILES ON DISK

There are no files on the flexible disk with extensions, "_D" or "_S" for LIF format, or "STA" or ".DTA" for DOS format.

114 CAN'T SAVE GRAPHICS WHEN COPY IN PROGRESS

If you attempt to save graphics when a print is in progress, this error message is displayed.

115 LIF-DOS COPY NOT ALLOWED

If you try to copy a file between the RAM disk and the flexible disk when the format of the RAM disk is different from the format of the flexible disk, this message is displayed.

116 NO STATE/DATA FILES ON MEMORY

There are no files on the RAM disk memory with extensions, "_D" or "_S" for LIF format, or ".STA" or ".DTA" for DOS format.

117 DUPLICATE FILE EXTENSION

The extension name entered is already used for other file types. Use other extension name.

119 NO DATA TRACE DISPLAYED

The **SCALE FOR [DATA]** is selected when the data trace is not displayed.

120 NO MEMORY TRACE DISPLAYED

The **SCALE FOR [MEMORY]** is selected when the memory trace is not displayed.

124 LIST TABLE EMPTY OR INSUFFICIENT TABLE

The frequency list is empty. To implement the list frequency mode, add segments to the list table.

125 CAN'T SET SLOPE ON IN POWER SWEEP

The slope function can be turned on in frequency sweep.

126 **CAN'T CHANGE NUMBER OF POINTS**

The number of points of the spectrum analyzer mode cannot be to change manually, except in zero span.

127 **CAN'T SET SWEEP TIME AUTO IN ZERO SPAN**

The automatic sweep time cannot be in zero span of the spectrum analyzer mode. (The network analyzer mode allows that the automatic sweep time is turned on.)

128 **SPAN = 0 ONLY**

The repetitive sampling is turn on when span must be zero, the sweep type must be linear frequency, and the trigger source must be EXT or VIDEO only. Confirm the analyzer setting and set appropriate setting for the repetitive sampling mode.

129 **LIN FREQ ONLY**

The repetitive sampling is turn on when span must be zero, the sweep type must be linear frequency, and the trigger source must be EXT or VIDEO only. Confirm the analyzer setting and set appropriate setting for the repetitive sampling mode.

130 **TRIG = EXT or VIDEO ONLY**

The repetitive sampling is turn on when span must be zero, the sweep type must be linear frequency, and the trigger source must be EXT or VIDEO only. Confirm the analyzer setting and set appropriate setting for the repetitive sampling mode.

131 **FREQUENCY SWEEP ONLY**

The sweep type must be frequency sweep when the center step size is set.

132 **COUPLED CHAN - BETWEEN NA & NA ONLY**

The analyzer types of both channels must be the network analyzer mode when the coupled channel is turned on.

133 **CAN'T CHANGE ON LIST SWEEP**

When list sweep is selected, the following parameters are not allowed to be changed:

- CENTER, SPAN, START, STOP
- NOP
- IFBW or RBW
- POWER

Modify the list table to change these parameters in the list sweep.

134 **CAN'T COUPLE IN CURRENT INPUTS**

When one channel measures a ratio measurement, and the other one measures an absolute measurement (for example: A/R and B), **COUPLED CH** can not be turned on.

141 **INSUFFICIENT MEMORY**

If a lot of tasks is executed at same time, memory might be insufficient for a while. (For example, running HP Instrument BASIC program, printing a screen, and sending or receiving data array by HP-IB are required at same time.) Please wait until finishing some tasks then execute the next task.

146 ON POINT NOT ALLOWD FOR THE CURRENT TRIG

The trigger event mode cannot be changed to the ON POINT mode because the current trigger source setting does not allow the ON POINT mode. The trigger event ON POINT mode is available for only MANUAL, EXTERNAL, and BUS trigger sources of the network analyzer mode.

154 INVALID DATE

The date entered to set the real time clock is invalid. Reenter correct date.

-100 Command error

This is a generic syntax error that the analyzer cannot detect more specific errors. This code indicates only that a command error, as defined in IEEE 488.2, 11.5.1.1.4, has occurred.

-101 Invalid character

A syntax element contains a character that is invalid for that type. For example, a header containing an ampersand (SENSE&).

-102 Syntax error

An unrecognized command or data type was encountered. For example, a string was received when the analyzer was not expecting to receive a string.

-103 Invalid separator

The parser was expecting a separator and encountered an illegal character. For example, the semicolon was omitted after a program message unit, *RST:TRIG.

-104 Data type error

The parser recognized an unallowed data element. For example, numeric or string data was expected but block data was encountered.

-105 GET not allowed

A Group Execute Trigger (GET) was received within a program message (see IEEE 488.2, 7.7).

-108 Parameter not allowed

More parameters were received than expected for the header. For example, the *SRE command only accepts one parameter, so receiving *SRE 4, 16 is not allowed.

-109 Missing parameter

Fewer parameters were received than required for the header. For example, the *SRE command requires one parameter, so receiving only *SRE is not allowed.

-110 Command header error

An error was detected in the header. This error message is used when the analyzer cannot detect the more specific errors described for errors -111 through -119.

–111 **Header separator error**

A character that is not a legal header separator was encountered while parsing the header. For example, no white space followed the header, thus *SRE4 is an error.

–112 **Program mnemonic too long**

The header contains more than twelve characters (see IEEE 488.2, 7.6.1.4.1).

–113 **Undefined header**

The header is syntactically correct, but it is undefined for the analyzer. For example, *XYZ is not defined for the analyzer.

–114 **Header Suffix out of range**

The value of a numeric suffix attached to a program mnemonic makes the header invalid.

–120 **Numeric data error**

This error, as well as errors –121 through –129, are generated when parsing a data element that appears to be numeric, including the nondecimal numeric types. This particular error message is used if the analyzer cannot detect a more specific error.

–121 **Invalid character in number**

An invalid character for the data type being parsed was encountered. For example, an alpha character in a decimal numeric or a “9” in octal data.

–123 **Exponent too large**

The magnitude of the exponent was larger than 32000 (see IEEE 488.2, 7.7.2.4.1).

–124 **Too many digits**

The mantissa of a decimal numeric data element contains more than 255 digits excluding leading zeros (see IEEE 488.2, 7.7.2.4.1).

–128 **Numeric data not allowed**

A legal numeric data element was received, but the analyzer does not accept it in this position for a header.

–130 **Suffix error**

This error, as well as errors –131 through –139, are generated when parsing a suffix. This particular error message is used if the analyzer cannot detect a more specific error.

–131 **Invalid suffix**

The suffix does not follow the syntax described in IEEE 488.2, 7.7.3.2, or the suffix is inappropriate for the analyzer.

–134 **Suffix too long**

The suffix contained more than 12 characters (see IEEE 488.2, 7.7.3.4).

-138 Suffix not allowed

A suffix was encountered after a numeric element that does not allow suffixes.

-140 Character data error

This error, as well as errors -141 through -148, are generated when analyzing the syntax of a character data element. This particular error message is used if the analyzer cannot detect a more specific error.

-141 Invalid character data

Either the character data element contains an invalid character or the particular element received is not valid for the header.

-144 Character data too long

The character data element contains more than twelve characters (see IEEE 488.2, 7.7.1.4).

-148 Character data not allowed

A legal character data element was encountered where prohibited by the analyzer.

-150 String data error

This error, as well as errors -151 and -158, are generated when analyzing the syntax of a string data element. This particular error message is used if the analyzer cannot detect a more specific error.

-151 Invalid string data

A string data element was expected, but was invalid for some reason (see IEEE 488.2, 7.7.5.2). For example, an END message was received before the terminal quote character.

-158 String data not allowed

A string data element was encountered but was not allowed by the analyzer at this point in parsing.

-160 Block data error

This error, as well as errors -161 and -168, are generated when analyzing the syntax of a block data element. This particular error message is used if the analyzer cannot detect a more specific error.

-161 Invalid block data

A block data element was expected, but was invalid for some reason (see IEEE 488.2, 7.7.6.2). For example, an END message was received before the length was satisfied.

-168 Block data not allowed

A legal block data element was encountered but was not allowed by the analyzer at this point in parsing.

-200 Execution error

This is the generic syntax error that the analyzer cannot detect more specific errors. This code indicates only that an execution error as defined in IEEE 488.2, 11.5.1.1.5 has occurred.

-210 Trigger error

A trigger related error occurred. This error message is used when the analyzer cannot detect the more specific errors described for errors -211 through -219.

-211 Trigger ignored

A GET, *TRG, or triggering signal was received and recognized by the analyzer but was ignored because of analyzer timing considerations. For example, the analyzer was not ready to respond.

-213 Init ignored

A request for a measurement initiation was ignored as another measurement was already in progress.

-220 Parameter error

Indicates that a program data element related error occurred. This error message is used when the analyzer cannot detect the more specific errors described for errors -221 through -229.

-221 Settings conflict

A legal program data element was parsed but could not be executed due to the current device state (see IEEE 488.2, 6.4.5.3 and 11.5.1.1.5).

-222 Data out of range

A legal program data element was parsed but could not be executed because the interpreted value was outside the legal range as defined by the analyzer (see IEEE 488.2, 11.5.1.1.5).

-223 Too much data

A legal program data element of block, expression, or string type was received that contained more data than the analyzer could handle due to memory or related device-specific requirements.

-224 Illegal parameter value

Used where exact value, from a list of possibilities, was expected.

-225 Data out of memory

The analyzer has insufficient memory to perform the requested operation.

-230 Data corrupt or stale

Possibly invalid data. New reading started but not completed since last access.

-231 Data questionable

Indicates that measurement accuracy is suspect.

-240 Hardware error

Indicates that a legal program command or query could not be executed because of a hardware problem in the analyzer. Definition of what constitutes a hardware problem is completely device-specific. This error message is used when the analyzer cannot detect the more specific errors described for errors -241 through -249.

-241 Hardware missing

A legal program command or query could not be executed because of missing analyzer hardware. For example, an option was not installed.

-250 Mass storage error

Indicates that a mass storage error occurred. This error message is used when the analyzer cannot detect the more specific errors described for errors -257.

-256 File name not found

A legal program command could not be executed because the file name on the device media was not found: for example, an attempt was made to read or copy a nonexistent file.

-257 File name error

Indicates that a legal program command or query could not be executed because the file name on the device media was in error. For example, an attempt was made to copy to a duplicate file name. The definition of what constitutes a file name error is device-specific.

-280 Program error

Indicates that a downloaded program-related execution error occurred. This error message is used when the analyzer cannot detect the more specific errors described for errors -281 through -289.

-281 Cannot create program

Indicates that an attempt to create a program was unsuccessful. A reason for the failure might include not enough memory.

-282 Illegal program name

The name used to reference a program was invalid. For example, redefining an existing program, deleting a nonexistent program, or in general, referencing a nonexistent program.

-283 Illegal variable name

An attempt was made to reference a nonexistent variable in a program.

-284 Program currently running

Certain operations dealing with programs may be illegal while the program is running. For example, deleting a running program might not be possible.

-285 Program syntax error

Indicates that a syntax error appears in a downloaded program. The syntax used when parsing the downloaded program is device-specific.

–286 **Program runtime error**

A program runtime error of the HP Instrument BASIC has occurred. To get a more specific error information, use the ERRM\$ or ERRN command of the HP Instrument BASIC.

–310 **System error**

Some error, termed “system error” by the analyzer, has occurred.

–311 **Memory error**

An error was detected in the analyzer’s memory.

–330 **Self-test failed**

A self-test failed. Contact your nearest Hewlett-Packard office or see the *Service Manual* for troubleshooting.

–350 **Queue overflow**

A specific code entered into the queue in lieu of the code that caused the error. This code indicates that there is no room in the queue and an error occurred but was not recorded.

–400 **Query errors**

This is the generic query error that the analyzer cannot detect more specific errors. This code indicates only that a query error as defined in IEEE 488.2, 11.5.1.1.7 and 6.3 has occurred.

–410 **Query INTERRUPTED**

A condition causing an interrupted query error occurred (see IEEE 488.2, 6.3.2.3). For example, a query followed by DAB or GET before a response was completely sent.

–420 **Query UNTERMINATED**

A condition causing an unterminated query error occurred (see IEEE 488.2, 6.3.2.2). For example, the analyzer was addressed to talk and an incomplete program message was received by the controller.

–430 **Query DEADLOCKED**

A condition causing a deadlocked query error occurred (see IEEE 488.2, 6.3.1.7). For example, both input buffer and output buffer are full and the analyzer cannot continue.

Index

Special characters

, 2-7
* , 2-8
 \square , 4-2
 \square , 4-2
-0, 2-8
 $\Delta L.F.$, 12-30
 $\Delta R.F.$, 12-30
 \uparrow , 2-8
 ϵ_r , 12-12
 τ_g , 12-14
 Δ marker , 7-5
 Δ mode, 12-30
 ΔX , 12-32
 ΔY , 12-32, 12-33
 \square , 4-2

1

16xPHASE (CONV MP16) , 5-11
1 M Ω input adapter, 9-2
1-port cal, 5-39
1/S (CONV ONEDS) , 5-10

2

2nd IF output, 2-11
2-port cal, 5-40

3

3.5mm (CALC APC35) , 5-40

4

4396A STATE (SAVDSTAC), 8-33, A-2
4xPHASE (CONV MP4) , 5-11

5

50 to 75 Ω adapter , 10-24
50 to 75 Ω input impedance conversion (option 1D7), 9-1
50 to 75 Ω minimum loss pad , 10-24

8

8xPHASE (CONV MP8) , 5-11

A

A (MEAS A) , 5-5, 5-8
A , 11-7
absolute amplitude accuracy , 10-3
absolute squared , 12-8
accessory, 9-1
accessory , 10-24
accessory part number, 10-24
active channel , 2-5
active channel block, 1-1
active channel block , 3-1
active entry area , 2-9
active probes, 9-2
adapter, 9-4
adapter kit, 9-4
AD converter, 12-4
ADD (LIMSADD), 8-14
ADD (SADD), 6-4, 6-8
additional amplitude error , 10-14
address , 8-19
ADDRESS:4396 , 8-19
addressable , 8-19, 12-36
ADDRESS:CONTROLLER (ADDRCONT), 8-19
adjust date , 8-11
ADJUST DISPLAY , 5-21
adjust time , 8-10
admittance, 5-10
admittance chart, 5-15
admittance conversion, 12-11
ADMITTANCE [Re Im] (FMT ADMIT), 5-15
aging , 10-7
altitude , 10-23
 A_m , 11-7
amplitude characteristics , 10-9
amplitude fidelity , 10-11
AMPLITUDE OFFSET (LIMIAMPO), 8-15
amplitude range , 10-9, 10-14
ANALYZER TYPE , 5-5, 5-7
ANALYZER TYPE , 5-8
 A_p , 11-7
aperture, 12-14
arbitrary impedance, 5-64, 12-44
ARBITRARY IMPEDANCE (STDT ARBI), 5-64

ascii save , 8-33
ATTEN (ATT), 5-29
ATTEN AUTO man (ATTAUTO ON|OFF), 5-29
attenuator, 12-8
attenuator , 2-7
ATTENUATOR PORT 1 (ATTP1), 6-15
ATTENUATOR PORT 2 (ATTP2), 6-16
attenuators , 6-15
auto attenuator, 5-29
AUTOREC , C-4
auto recall , C-4
AUTO SCALE (AUTO), 5-27
auto scaling, 5-27
AUX OFFSET VALUE (DATAOVAL), 5-20
average continuous power , 10-11
averaging, 5-31, 5-33, 12-12
averaging , 12-5, 12-8
AVERAGING FACTOR (AVERFACT), 5-31, 5-33
averaging ON Avg , 2-8
AVERAGING on OFF (AVER ON|OFF), 5-33
AVERAGING on OFF (AVER ON|OFF), 5-31
AVERAGING RESTART (AVERREST), 5-31,
5-33
Avg , 2-8

B

B (MEAS B) , 5-5, 5-8
BACKGROUND INTENSITY (BACI), 5-22
BACK SPACE, 8-7
Back Space , 4-3
BACK SPACE , 5-26
basic screen, 5-20
battery backup, D-1
beep done , 8-12
BEEP DONE ON off (BEEPDONE ON|OFF),
8-12
beeper , 8-4
BEEPER MENU , 8-4
beep fail , 8-14
BEEP FAIL on OFF (BEEPFAIL ON|OFF),
8-14
beep warning , 8-12
BEEP WARN on OFF (BEEPWARN ON|OFF),
8-12
block , 1-1
block diagram , 12-2
bnc cable , 10-24
bnc-n adapter , 10-24
B/R (MEAS BR), 5-5
BRIGHTNESS (CBRI), 5-25

Bus , 2-8
BW, 12-30
Bw/Avg , 1-2, 5-31

C

C , 11-7
C! , 2-8, 5-38
C?, 2-8
C? , 5-38
C0 (C0) , 5-63
C1 (C1) , 5-63
C2 (C2) , 5-63
C2 , 2-8
C2! , 2-8, 5-38
C2? , 2-8, 5-38
cable, 9-4
cable reflection stability , 11-7
cable transmission stability , 11-7
Cal , 5-35
Cal , 1-2
CALIBRATE MENU , 5-38
CALIBRATE:NONE (CALI NONE) , 5-38
calibration, 12-38
calibration coefficient arrays , 12-5
calibration coefficients arrays , C-2
calibration kit, 9-4, D-13
calibration kit , 5-42
calibrator accuracy , 10-11
cal kit, 5-40
CAL KIT [7mm] , 5-40
CAL KIT:7mm (CALK APC7) , 5-40
CAL KIT DEFINITION , 8-24
cal kit list , 8-24
CAL on OFF (SAVCAL ON|OFF), 8-35
cal out connector , 2-4
cal output , 10-13
CANCEL , 8-7, 8-40
CANCEL , 5-26
CAT , 8-6
cent, 12-30
CENTER (CENT), 6-12, 6-14
Center , 1-3
CENTER STEP SIZE (CNTS), 6-22
center value , 2-7
CH1 DATA (COLO CH1D), 5-22
CH1 MEM/LIMIT LINE (COLO CH1M), 5-23
CH2 DATA (COLO CH2D), 5-23
CH2 MEM/LIMIT LINE (COLO CH2M), 5-23
Chan 1 (CHAN1) , 3-1

Chan 2 (CHAN2), 3-1
CHANGE DIRECTORY (CHAD), 8-34
CHANGE YES, 8-9
 channel coupling, 6-3, 12-20
 characteristic impedance, 5-41, 5-61
 class, 12-43
 class assignment, D-15
CLASS ASSIGNMENT (CALCASSI), 8-27
CLASS DONE (SPEC'D) (CLAD), 5-59
 class list, 8-27
CLEAR I/O, 8-7
 clear list, 6-10
CLEAR LIST (CLEL), 6-4, 6-8
CLEAR LIST (LIMCLEL), 8-15
 clear list table, 8-15
CLEAR LIST YES, 6-10
 clear markers, 7-3
 clear sub-marker, 7-8
CLEAR SUB MKR (SMKR [1-7] OFF), 7-3
 clock, 8-4, 8-10
 close-field probe, 9-3
 coefficient, 12-43
COLOR (COLOR), 5-25
 color adjust, 5-22
 color intensity, 5-22
 color monitor, 2-10
 color print, 8-25
 color printer, 8-22
COMMAND ENTRY, 8-7
 command entry, 8-7
 connectors, 2-9
Continue, 8-5
CONTINUOUS (CONT), 6-19
 continuous, 7-4
 continuous mode, 12-29
 controller, 12-35
 control program, 8-5
CONVERSION [], 5-6
CONVERSION [OFF], 5-5
 conversion, 12-6
 conversion function, 12-11
Copy, 1-4
COPY ABORT (COPA), 8-22, 8-30
 copy abort, 8-22, 8-30
COPY FILE (FILC), 8-34
 copy file, 8-34
COPY SKEY on OFF (PRSOFT ON|OFF), 8-22
COPY TIME on OFF (COPT ON|OFF), 8-22,
 8-30
 Cor, 2-8

correction on off, 5-37
COUPLED CH ON off (COUC ON|OFF), 6-3
 coupling, 12-20
 coupling, 10-13
 coupling channels, 3-2
 Cp1, 2-6
CREATE DIRECTORY (CRED), 8-34
 cross channel, 7-11
 cross channel ONXch, 2-6
CROSS CHAN on OFF (CRSC ON|OFF), 7-11
 crosstalk, 10-3, 10-13, 12-39, 12-41
 crt, 2-4, 10-20
CTR & SPAN (DISMPRM CTSP), 8-29
CW FREQ (CWFREQ), 6-15
 cw frequency, 2-7

D

D, 11-7
 data, 5-18
 data arrays, 12-5, 12-9, C-2
DATA HOLD [] (DHOLD OFF|MAX|MIN),
 5-19
 data hold, 12-6, 12-9
 data math, 5-19
DATA MATH [] (MATH
 DATA|DMNM|DPLM|DDVM), 5-19
 data math, 10-20, 12-6, 12-9
 data math gain ON G+, 2-8
 data math offset ON -0, 2-8
 data math ON D-M, D+M, D/M, H1d, 2-8
DATA & MEMORY (DISP DATM), 5-19
 data only, C-2
DATA ONLY, 8-32
DATA on OFF (SAVDAT ON|OFF), 8-35
 data processing, 12-3
DATA-MEMORY (DATMEM), 5-19
 data trace array, 12-9
 data trace arrays, 12-6, C-3
DATA TRACE on OFF (SAVDTRC ON|OFF),
 8-35
 data transfer formats, 10-20
 date format, 8-11
DATE MM/DD/YY (SETCDATE), 8-11
DATE MODE: MonDayYear (MONDAYEAR)
 MonDayYear, 8-11
DayMonYear (DAYMYEAR), 8-11
dB μ V (SAUNIT DBUV), 5-16
dBV (SAUNIT DBV), 5-16
 dc offset correction, 12-8
 decimation, 12-7

default color, 5-25
 DEFAULT COLORS (DEFC), 5-24
 DEFAULT GAIN & OFS, 5-19
 default setting, D-1
 DEFAULT SETUP (DFLT), 8-26
 defined std 1 (STANA), 5-44
 defined std 2 (STANB), 5-44
 defined std 3 (STANC), 5-44
 defined std 4 (STAND), 5-44
 defined std 5 (STANE), 5-44
 defined std 6 (STANF), 5-44
 defined std 7 (STANG), 5-44
 DEFINE SAVE DATA, 8-32, 8-33
 define standard, 5-56
 DEFINE STANDARD, 5-56
 Del, 2-8
 delay, 12-44
 DELAY (FMT DELA), 5-14
 delay/thru, 5-63
 DELAY/THRU (STDT DELA), 5-63
 DELETE (LIMSDDEL), 8-14
 DELETE (SDEL), 6-4, 6-8
 DELTA LIMIT (LIMD), 8-17
 delta limit, 8-17
 Δ marker, 7-5
 Δ marker—funciton, 7-11
 AMKR (DMKR ON), 7-5
 AMKR SWP PARAM (DMKRPRM), 7-6
 Δ mode, 12-30
 AMODE MENU, 7-4
 AMODE OFF (DMKR OFF), 7-5
 DETECTION [], 5-8
 detection mode, 12-16
 deviation from linear phase, 10-5
 differential probe, 9-3
 digital filter, 12-4
 dimensions, 10-24
 directional bridge, 9-3
 directivity, 12-39, 12-47
 directivity E_{DF} , 12-53
 directivity E_{DR} , 12-53
 disc, 9-5
 discrete, 7-4
 discrete mode, 12-29
 disk capacity, C-1
 disk drive non-operating condition, 10-23
 disk drive operating condition, 10-23
 disk format, 8-34, 10-20, C-1

Display, 5-17
 display, 2-4, 10-20
 Display, 1-2
 DISPLAY ALLOCATION (DISA
 ALLI|HIHB|ALLB|BASS), 5-20
 DISPLAY: DATA (DISP DATA), 5-18
 displayed average noise level, 10-11, 10-14
 DISPLAY LIST (DISL), 8-29
 DISPLAY LIST (DISLLIST), 8-28
 display point, 6-7
 display points, 6-3, 12-19
 display unit, 10-9
 DISP MODE: ST & SP (DISMPRM STSP)
 ST and SP, 8-29
 DISP MODE: UPR & LWR (DISMAMP UL),
 8-28
 D+M, 2-8
 D/M, 2-8
 D-M, 2-8
 D&M SCALE [] (SCAC ON|OFF), 5-30
 D&M SCALE [COUPLE] (SCAC ON|OFF), 5-28
 DONE, 8-7, 8-9
 DONE, 5-26
 DONE: 1-PORT CAL (SAV1), 5-46, 5-47
 DONE: 2-PORT CAL (SAV2), 5-51, 5-54
 DONE (LIMEDONE), 8-15
 DONE (LIMSDON), 8-17
 DONE RESP ISOL'N CAL (RAID), 5-45
 DONE: RESPONSE (RESPDONE), 5-44
 DPI (DPI), 8-25
 drift error, 12-39
 drift error, 11-6
 dual channel, 5-18
 DUAL CHAN on OFF (DUAC ON|OFF), 5-18
 dynamic accuracy, 11-7, 11-10
 dynamic accuracy (a/r, b/r), 10-3, 10-5
 dynamic range, 10-9

E

E_{DF} , 12-47
 EDGE (GATCTL EDG), 6-19
 edge mode, 12-24
 Edit, 8-6
 EDIT (LIMSEDI), 8-14
 EDIT (SEDI), 6-4, 6-8
 EDIT LIMIT LINE (EDITLIML), 8-14
 edit limit table, 8-14
 EDIT LIST (EDITLIST), 6-4, 6-8

edit program , 8-6
 ELEC DELAY MENU , 5-28
 electrical delay, 5-28, 12-12
 electrical delay , 5-42, 12-6
 ELECTRICAL DELAY (ELED), 5-28
 E_{LF}, 12-52
 emc , 10-24
 END EDIT , 8-6
 enter characters, 5-26
 enter characters , 8-40
 enter step size, 6-22
 entry block, 1-2
 entry block , 4-1
 Entry Off , 4-3
 equivalent length, 12-12
 ERASE TITLE , 5-26
 E_{RF}, 12-48
 E_{rm} , 11-8
 E_{rp} , 11-8
 error, 12-39
 error correction ON Cor , 2-8
 error message, Messages-1
 error model, 12-47
 E_{SF}, 12-48
 E_{TF}, 12-53
 event trigger , 10-6
 E_{XF}, 12-53
 expanded phase, 5-15
 EXPANDED PHASE (FMT EXPP), 5-15
 EXECUTE LVL CAL (LVLCAL) , 5-65
 Ext , 2-8
 EXTENSION INPUT A (PORTA) , 5-55
 EXTENSION INPUT B (PORTB) , 5-55
 EXTENSION INPUT R (PORTR) , 5-55
 EXTENSION PORT 1 (PORT1) , 5-55
 EXTENSION PORT 2 (PORT2) , 5-55
 EXTENSIONS on OFF (PORE ON|OFF) , 5-55
 EXTERNAL (TRGS EXT), 6-19
 external monitor, 9-5
 external monitor output, 10-23
 external monitor terminal, 2-10
 external program run/cont input , 2-10,
 10-22
 external reference, 2-8
 external reference input , 2-10, 10-21
 external trigger input , 2-11, 10-22

F

factory setting, D-1, D-12
 fast fourier transform , 12-8
 fast sweep indicator ↑ , 2-8

features , 1-1
 female , 5-44
 FFT , 12-8
 FFT Mode, 12-16
 file name (PURG), 8-37
 file name (RECD), 8-41
 file name (RESAVED), 8-36
 file name , C-4
 FILE UTILITIES , 8-33
 filter level correction , 12-8
 FIXED AMKR (DMKR FIX), 7-5
 FIXEDAMKR AUX VALUE (DMKRAUV), 7-6
 FIXEDAMKR VALUE (DMKRVAL), 7-6
 fixed Δmarker, 7-6
 flexible disk drive , 2-4
 floppy disk , 10-24
 FORMAT [] (DISF LIF|DOS), 8-34
 format , 2-6, 12-6, 12-9
 Format , 1-2, 5-13
 FORMAT:LOG MAG (FMT LOGM), 5-14
 FORMAT:SPECTRUM (FMT SPECT), 5-16
 FORM FEED ON off (FORMFEED ON|OFF),
 8-23
 FREE RUN (TRGS INT), 6-19
 frequency blank, 5-21
 FREQUENCY BLANK , 5-21
 frequency characteristics , 10-7
 frequency characteristics conversion, 12-5
 frequency characteristics correction , 12-5
 frequency characteristics level correction,
 12-8
 frequency for power sweep, 6-15
 frequency range , 10-2, 10-7
 frequency readout accuracy , 10-7
 frequency reference , 10-7
 frequency response , 10-5, 10-11, 10-14,
 12-39, 12-42, 12-47, 12-48, 12-52
 front panel , 2-1
 FULL 2-PORT (CALI FUL2) , 5-40
 full scale input level , 10-2
 full span, 6-24
 FULL SPAN (FULS), 6-24
 full two-port calibration , 12-42
 function reference , 10-24
 FWD ISOL'N ISOL'N STD (FWDI) , 5-50,
 5-53
 FWD.MATCH (LABEFWDM) , 5-59
 FWD.MATCH (SPECFWDM) , 5-58
 FWD.MATCH THRU (FWDM) , 5-49, 5-53
 FWD.TRANS. THRU (FWDT) , 5-49, 5-53

G

gain, 5-20
GAIN (DATGAIN), 5-20
gain compression, 10-11
G*, 2-8
GATE[] (TRGS GAT), 6-19
gate control mode, 10-14
GATE CTL:LEVEL (GATCTL LEV), 6-19
GATE DELAY (GATDLY), 6-19
gate delay, 10-14
gated sweep, 12-24
gate length, 12-24
GATE LENGTH (GATLEN), 6-19
gate length, 10-14, 12-27
GATE[LEVEL] (GATCTL LEV|EDG), 6-19
gate output, 2-11, 10-14
gate trigger, 6-19
gate trigger input, 10-14
gate trigger mode, 12-24
general characteristics, 10-21
GET, 8-6
G+jB (CIRF GB), 7-28
G/n, 4-2
G&O, 2-8
graphics, 8-33
GRAPHICS, C-3
GRAPHICS (SAVDTIFF), 8-33, A-4
graphics file, C-3
GRATICULE (COLO GRAT), 5-23
group delay, 5-14, 12-13
group delay aperture, 5-32
group delay characteristics, 10-6
GROUP DELY APERTURE (GRODAPER), 5-32

H

handle kit (option 1CN), 9-1
harmonics, 10-2
high level noise, 11-7
high stability frequency reference (option 1D5), 9-1
Hld, 2-8
h:m:s, 6-3, 6-6
hold ON Max,Min, 2-8
HP 10833A hp-ib cable(1 m), 9-5
HP 10833B hp-ib cable(2 m), 9-5
HP 10833C hp-ib cable(3 m), 9-5
HP 10833D hp-ib cable(0.5 m), 9-5
HP 10855A broadband preamplifier, 9-3
HP 1122A probe power supply, 9-3
HP 1141A differential probe, 9-3
HP 11667A power splitter, 9-3
HP 11825B minimum loss pad, 10-24

HP 11850C,D three-way power splitters, 9-3
HP 11851B 50 Ω type-n rf cable set, 9-4
HP 11852B 50 Ω to 75 Ω minimum loss pad, 9-4
HP 11853A 50 Ω type-n adapter kit, 9-4
HP 11854A 50 Ω bnc adapter kit, 9-4
HP 11855A 75 Ω type-n adapter kit, 9-4
HP 11856A 75 Ω bnc adapter kit, 9-4
HP 11857B 75 Ω type-n test port return cable set, 9-4
HP 11857D 7 mm test port return cable set, 9-4
HP 11940A probe, 9-3
HP 11941A probe, 9-3
HP 11945A close-field probe set, 9-3
HP 41800A active probe, 9-2
HP 41802A 1 M Ω input adapter, 9-2
HP 4396U upgrade kit, 9-1
HP 54701A active probe, 9-2
HP 85024A high frequency probe, 9-2
HP 85031B 7 mm calibration kit, 9-4
HP 85031B 7 mm calibration kit, 5-42
HP 85032B 50 Ω type-n calibration kit, 9-4
HP 85032B 50 Ω type-N calibration kit, 5-42
HP 85033C 3.5 mm calibration kit, 9-4
HP 85033C 3.5 mm calibration kit, 5-42
HP 85036B 75 Ω type-n calibration kit, 9-4
HP 85036B 75 Ω type-N calibration kit, 5-42
HP 85043B system rack, 9-5
HP 85046A/B s parameter test set, 9-2
HP 86205A 75 Ω rf bridges, 9-3
HP 86207A 75 Ω rf bridges, 9-3
HP 87405A preamplifier, 9-3
HP 87512A, B, 12-54
HP 87512A/B transmission/reflection test set, 9-2
HP 92192A micro flexible disks, 9-5
HP 92192X micro flexible disks, 9-5
HP DeskJet 1200 color printer, 9-5
HP DeskJet 1600CM color printer, 9-5
HP DeskJet 340J color printer, 9-5
HP DeskJet 505 printer, 9-5
HP DeskJet 560C color printer, 9-5
HP DeskJet 850C color printer, 9-5
HP-IB, 12-34
hp-ib, 10-20
hp-ib address, 8-19
HP-IB address, 12-37, D-12
hp-ib cable, 9-5
hp-ib command reference, 10-24
HP-IB interface, 2-10
hp instrument basic users handbook, 10-24
hp part number, 10-24
humidity, 10-23

I

IBASIC, 8-4
ibasic, 8-4
IBASIC (COLO IBT), 5-23
IF band reduction, 12-13
if bandwidth, 5-32
IF Bandwidth (IFBW), 10-2
IF BW (BW), 6-12
ifbw, 2-7
IF BW (BW), 5-32
IF gain switching uncertainty, 10-12
IF output, 2-11
IF range adjustment, 12-8
IF range adjustment, 12-8
imaginary, 5-15
IMAGINARY (FMT IMAG), 5-15
impedance, 5-10
impedance, 10-2, 10-3, 10-13
impedance conversion, 12-11
Impedance Measurement Function (option 010), 9-1
initial achievable accuracy, 10-1, 10-7
initialize, D-1
INITIALIZE, 8-7
INITIALIZE (INID), 8-34
initialize, 8-34
INITIALIZE DISK: YES, 8-39
INP8IO?, 12-56
input attenuator, 2-7, 10-11
input attenuator switching uncertainty, 10-12
input characteristics, 10-2, 10-13
input crosstalk, 10-2
input impedance, 5-65
input ports, 5-8
INPUT PORTS, 5-6
input S, 2-4
inputs R, A, and B, 2-3
INPUT Z (INPZ), 5-65
Instrument data arrays, C-2
instrument state block, 1-3
Instrument states and internal data arrays, C-2
INTENSITY (INTE), 5-22
interface function, 10-20
internal reference output, 2-10, 10-21
interpolated error correction ON C?, C2?, 2-8
introduction, 1-1
i/o port, 2-10, 10-21, 12-56
i/o port pin assignments, 10-21
isolation, 5-45, 5-50, 5-53

ISOLATION (ISOL), 5-50, 5-53
isolation, 12-39, 12-41, 12-52
ISOLATION DONE (ISOD), 5-50, 5-54
isolation error, 12-53
isolation E_{XF}, 12-53
isolation E_{XR}, 12-53
ISQL'N STD (RAII SOL), 5-45

K

keyboard, 10-24
keyboard connector, 2-10, 10-21
KIT DONE (MODIFIED) (KITD), 5-60
(k/m), 4-2
knob, 4-2

L

label cal kit, 5-60
label class, 5-59
LABEL CLASS, 5-59
LABEL DONE, 5-60
LABEL:FWD TRANS. (LABEFWDT), 5-59
LABEL KIT (LABK), 5-60
LABEL: S11A (LABES11A), 5-59
LABEL: S22A (LABES22A), 5-59
label standard, 5-64
LABEL STD (LABS), 5-64
ORIENT [PORTRAIT] (LANDSCAPE ON|OFF), 8-23
LEFT MARGIN (LMARG), 8-26
left peak, 7-18
level accuracy, 10-2, 10-11, 10-14
level cal, 5-65
level calibration, 12-18
level mode, 12-25
lif (logical inter change format), C-1
limit line, 8-13
limit line concept, 12-21
limit line offset, 8-15
LIMIT LINE OFFSETS, 8-15
LIMIT LINE on OFF (LIMILINE ON|OFF), 8-13
LIMIT MENU, 8-4
limit table, 8-24
limit testing, 8-4, 8-13
LIMIT TEST on OFF (LIMITEST ON|OFF), 8-13
LIMIT TEST TABLE, 8-24
linear magnitude, 5-15
linear phase shift, 12-13
linear sweep, 6-4, 6-7

line switch , 2-4
 LIN MAG (FMT LINM), 5-15
 LIN MAG PHASE (CIRF LIN), 7-28
 LIST , 8-7
 LIST DONE (EDITDONE), 6-5, 6-8
 listener , 12-34
 LIST FREQ (SWPT LIST), 6-8
 listing , 8-23
 list sweep, 6-4, 6-8
 LIST SWEEP TABLE , 8-24
 list table, 6-4, 6-8
 list table , 8-29
 LIST VALUES (LISV), 8-23
 load, 5-63, 12-44
 LOAD (CLASS11C) , 5-46, 5-49, 5-52
 LOAD (CLASS22C) , 5-47, 5-49
 LOAD (STDT LOAD) , 5-63
 load match , 12-39, 12-41, 12-52
 load match E_{LF} , 12-53
 load match E_{LR} , 12-53
 load match error , 12-52
 Local , 1-3
 local oscillator feedthrough , 10-11
 log magnitude, 5-14
 LOG MAG PHASE (CIRF LOG) , 7-28
 log sweep, 6-4
 loss, 12-30
 LOWER LIMIT (LIML), 8-16
 lower limit , 8-16
 LVL CAL DATA (LVCDT) , 5-65

M

magnitude characteristics , 10-3
 magnitude dynamic accuracy , 11-7
 magnitude multiplexer switching uncertainty
 , 11-7
 male , 5-44
 Man , 2-8
 MANUAL (TRGS MAN), 6-19
 manual changes, A-1
 marker, 12-29
 Marker , 1-3
 marker block , 1-3
 marker couple ONCp1, 2-6
 marker coupling, 7-3
 marker data readout , 2-6
 marker list, 7-26, 7-27
 Marker (MKR ON), 7-2
 marker search, 12-30
 marker statistics , 2-6
 marker time, 7-26, 7-27

marker time mode , 12-29
 Marker→ , 1-3
 Max, 2-6
 MAX (SEAM MAX), 7-15
 Max , 2-8
 max hold, 5-19
 maximum hold ON Max , 2-8
 maximum safe input level , 10-3, 10-11
 max mixer level, 5-30
 MAX MIXER LEVEL (MAXMLEV), 5-30
 max search, 7-15
 Meas , 1-2
 Meas , 5-3
 measured input , 2-6
 measurement basic, 12-10
 measurement basic accuracy (supplemental
 performance characteristics) , 10-16
 measurement block, 1-2
 measurement block , 5-1
 measurement error, 12-39
 measurement format , 10-9
 measurement points, 12-19
 MEASURE RESTART (REST), 6-20
 MEM on OFF (SAVMEM ON|OFF), 8-35
 memory , 5-19
 MEMORY (DISP MEMO), 5-19
 memory arrays , 12-5, 12-9, C-2
 MEMORY PARTITION , 8-4
 memory partition , 8-4, 8-9
 memory trace array , 12-9
 memory trace arrays , 12-6, C-3
 MEM TRACE on OFF (SAVMTRC ON|OFF),
 8-35
 menu , 2-2
 message area, 2-9
 MID & DLT (DISMAMP MD), 8-28
 MIDDLE VALUE (LIMM), 8-17
 middle value , 8-17
 MIN (SEAM MIN), 7-15
 Min , 2-6, 2-8
 min hold, 5-19
 minimum hold ON Min , 2-8
 min search, 7-15
 MKR [CONT] (MKRCONT ON|OFF), 7-4
 MKR [UNCOUPLE] (MKRCOUP OFF|ON), 7-3
 MKRA→CENTER (MKRDCEM), 7-11
 MKRA→SEARCH RNG (SEARSTR), 7-25
 MKRA→SPAN (MKRDSPAN), 7-11
 MKRA→CNTR STEP (MKRDCSTE), 6-22
 MKRA→SPAN (MKRDSPAN), 6-24

MKR LIST on OFF (MKRL ON|OFF), 7-26, 7-27
MKR ON [DATA] (MKRO DATA|MEMO), 7-3
MKR →REFERENCE (MKRREF), 7-10
MKR →AMP.OFS. (MKRAMPO), 8-15
 mkr → function, 7-10
MKRSA →CENTER (MKRDCEM), 6-22
MKR TIME on OFF (MKRTIME ON|OFF), 7-26, 7-27
MKR →CENTER (MKRCENT), 6-22, 7-10
MKR →CNTR STEP (MKRCSTE), 6-22
MKR →DELAY (MKRDELA), 5-28
MKR →LEFT RNG (SEARSTRL), 7-25
MKR →MIDDLE (MKRMIDD), 8-17
MKR →OFFSET (MKROFS), 5-20
MKR →PEAK DELTA (MKRPKD), 7-22
MKR →REFERENCE (MKRREF), 5-28, 5-29
MKR →RIGHT RNG (SEARSTRR), 7-25
MKR →START (MKRSTAR), 7-10
MKR →STOP (MKRSTOP), 6-11, 6-13, 7-10
MKR →SWP PARAM (MKRSWPRM), 8-16
MKR →THRESHOLD (MKRTHRE), 7-22, 7-24
MKR ZOOM (MKRZM), 7-10
 M_1 , 11-7
M/L, 4-2
MODIFY [] (MODI1), 5-41
 modify cal kit, 5-41
MODIFY COLORS, 5-22
 modifying calibration kit, 12-43
MORE, 6-12
 M_s , 11-7
MSI [INTERNAL], 8-7
 M_{sw} , 11-7
 multiple phase, 5-11
 multiplexer switching uncertainty, 11-7
N
N 50 ohm (CALC N50), 5-40
N 75 ohm (CALC N75), 5-41
 Neg, 2-8
 negative peak, 5-12
 negative peak detection ON Neg, 2-8
NEG PEAK (DET NEG), 5-12
 network analyzer, 5-9
NETWORK ANALYZER (NA), 5-9
NETWORK: A/R (MEAS AR), 5-5

network measurement, 5-5
 network measurement basics, 12-10
NEXT FILES, 8-36, 8-37, 8-41
NEXT PAGE (NEXP), 8-30
 next peak, 7-18
NEXT PEAK (SEANPK), 7-18
NEXT PEAK LEFT (SEANPKL), 7-18
NEXT PEAK RIGHT (SEANPKR), 7-18
 N_h , 11-7
 N_1 , 11-7
nn K RAM mmK BASIC, 8-9
NO, 8-9, 8-38, 8-39
NO, 6-10
NOISE (FMT NOISE), 5-16
 noise floor, 11-7
NOISE FORM on OFF (MKRNOI ON|OFF), 7-26
 noise level, 10-2
 noise marker, 7-26
 noise measurement, 5-16, 12-18
 noise sidebands, 10-2, 10-7
 nominal, 10-1
 non-harmonics spurious, 10-2
 non-operation condition, 10-23
 non-volatile memory, D-1
NOP, 12-19
 notations, 2-8
 number of display points, 10-13
NUMBER of GROUPS (NUMG), 6-18
NUMBER of POINTS (POIN), 6-3, 6-7, 6-11
 numeric keypad, 4-2
O
OFF (CONV OFF), 5-10
OFFSET (DATOVAL), 5-20
 offset correction, 12-8
 offset delay, 5-61
OFFSET DELAY (OFSD), 5-61
 offset Delay, 12-45
 offset loss, 5-61
OFFSET LOSS (OFSL), 5-61
 offset Loss, 12-45
 offset value, 5-20
OFFSET ZO (OFSZ), 5-61
 offset Z_0 , 12-45
OMIT ISOLATION (OMII), 5-50, 5-53
ONE PATH 2-PORT (CALI ONE2), 5-40
 one-path two-port calibration, 12-42
 one-port calibration, 12-42
 one-port error model, 12-47

on-screen dynamic range , 10-8
open, 5-62, 12-44
OPEN (STANB) , 5-43
OPEN [F] (STAND) , 5-44
OPEN [M] (STANC) , 5-44
OPERATING PARAMETERS (OPEP) , 8-24
operation condition , 10-23
option, 9-1
option OBW , 10-24
option 1D5 , 2-10, 2-11
option 1D6 , 2-11, 10-14
option 1D7 , 10-14, 10-24
OUT8IO , 12-56
output characteristics , 10-1, 10-13
over write , 8-33

P

P , 2-8
P? , 2-8
parallel interface , 2-10
Parallel interface , 10-20
parameter list , 8-24
part number , 10-24
PART SRCH on OFF (PARS ON|OFF) , 7-25
pass/fail , 2-6
Pause , 8-6
P| , 2-8
PEAK (SEAM PEAK) , 7-18
Peak , 2-6
PEAK → CENTER (PEAKCENT) , 7-11
peak definition, 12-32
PEAK DEF MENU , 7-15
peak delta, 7-22
PEAK DELTA: ΔX (PKDLTX) , 7-22
PEAK DELTA: ΔY (PKDLTY) , 7-24
PEAK DELTA: ΔY (PKDLTY) , 7-22
peak detector , 12-8
PEAK PLRTY POS neg (PKPOL POS|NEG) ,
7-22
peak polarity, 7-22
peak polarity , 12-32
peak pulse power , 10-11
peaks all, 7-15
peak search, 7-15
PEAKS LEFT (SEAM PKSL) , 7-15
PEAKS RIGHT (SEAM PKSR) , 7-15
PEAK → CENTER (PEAKCENT) , 6-23
PEN 1 (COLO PEN1) , 5-23
PEN 2 (COLO PEN2) , 5-23

PEN 3 (COLO PEN3) , 5-23
PEN 4 (COLO PEN4) , 5-23
PEN 5 (COLO PEN5) , 5-24
PEN 6 (COLO PEN6) , 5-24
pen color, 5-23
performance , 10-1
performance test , 10-1
performance test manual , 10-24
phase, 5-14
PHASE (FMT PHAS) , 5-14
phase characteristics , 10-5
phase dynamic accuracy , 11-7
phase multiplexer switching uncertainty ,
11-7
phase offset, 5-28
phase offset , 12-6
PHASE OFFSET (PHAO) , 5-28
phase shift, 12-13
PksA , 2-6
PksL , 2-6
PksR , 2-6
polar chart, 5-15, 12-12
POLAR [Re Im] (FMT POLA) , 5-15
port extension, 5-41, 5-55
port extension , 5-42
PORT EXTENSIONS , 5-41
positive peak, 5-12
POS PEAK (DET POS) , 5-12
POWER (POWE) , 6-15, 6-17
POWER (POWER) , 6-11, 6-13
power , 2-10
power level, 6-15
power level , 2-7
power range , 10-1
power requirements , 10-24
power slope ON S1p , 2-8
power splitter, 9-3
power sweep, 6-4
power sweep linearity , 10-1
preamplifier , 9-3
precision frequency reference , 10-7
(Preset) , D-1
preset , 8-20
(Preset) , 1-4, 2-3
PRESET MKRS (PRSMKRS) , 7-3
preset state, D-1
PREV FILES , 8-36, 8-37, 8-41
PREV PAGE (PREP) , 8-30
print , 8-22, 8-30
PRINT COLOR [FIXED] (PRICFIXE,
PRICVARI) , 8-25

printer, 9-5
printer control language, 10-20
PRINT SETUP, 8-22
PRINT [STANDARD] (PRINALL), 8-22, 8-30
PRINT STANDARD (PRIS), 8-25
probe power, 10-21
probe power connector, 2-3
programming guide, 10-24
pulse width (T_p), 10-22
PURGE, 8-7
PURGE FILE (PURG), 8-34
purge file, 8-34
PURGE: YES, 8-38

Q

Q, 12-30

R

R (MEAS R), 5-5
R (MEAS R), 5-8
rack mount and handle kit (option 1CP), 9-2
rack mount kit (1CM), 9-2
RAM disk, C-1
random error, 12-39
random error, 11-6
range adjustment, 12-5
ratio, 12-5
ratio accuracy, 10-3
raw data arrays, 12-5, 12-8, C-2
RAW on OFF (SAVRAW ON|OFF), 8-35
rbw, 2-7
RBW filter response time, 12-26
RBW/SPAN RATIO (BWSRAT), 5-34
rbw switching uncertainty, 10-12
real, 5-15
REAL (FMT REAL), 5-15
REAL IMAG (CIRF RI), 7-28
rear panel, 2-9
Recall, 1-4
recall color, 5-24
RECALL COLORS (RECC), 5-24
recall file, 8-41
RECALL LINE, 8-6
receiver characteristics, 10-2
recharge time, D-1
reference, 5-27, 5-29
reference level, 2-6
reference level range, 10-9
reference oven output, 2-11, 10-21
REFERENCE POSITION (REFP), 5-27
REFERENCE VALUE (REFV), 5-27, 5-29

reflection cal, 5-48, 5-52
reflection coefficient, 12-47
reflection repeatability, 11-7
reflection tracking drift, 11-7
reflection tracking E_{RF} , 12-53
reflection tracking E_{RR} , 12-53
reflection uncertainty equations, 11-8
REFLECT'N (REFL), 5-48, 5-52
REFLECT'N DONE (REFD), 5-49, 5-53
Ref1: FWD S11 [A/R] (MEAS S11), 5-6
Ref1: REV S22 [A/R] (MEAS S22), 5-6
relative permittivity ϵ_r , 12-12
REMOTE indicator, 2-3
RENumber, 8-7
repetitive sampling, 12-28
RE-SAVE, 8-6
RE-SAVE FILE (RESAVD), 8-33
RES BW (BW), 6-13
RES BW [] (BW), 5-34
RES BW AUTO man (BWAUTO ON|OFF), 5-33
RESET, 8-8
RESET COLOR (RSCO), 5-25
residual crosstalk, 11-7
residual fm, 10-8
residual load match, 11-7
residual measurement error, 11-6
residual reflection tracking, 11-7
residual response, 10-11
residual responses, 10-5
residual source match, 11-7
residual transmission tracking, 11-7
resolution bandwidth, 5-33
resolution bandwidth (rbw), 10-7
response, 5-45
RESPONSE (CALI RESP), 5-39
RESPONSE (LABERESP), 5-60
RESPONSE (RAIRESP), 5-45
RESPONSE (SPECRESP), 5-58
response, 5-39
response and isolation, 5-39
response and isolation calibration, 12-42
RESPONSE & ISOL'N (CALI RAI), 5-39
RESPONSE & ISO'N (LABERESI), 5-60
RESPONSE & ISO'N (SPECRESI), 5-58
response calibration, 12-42
response for 3.5 mm/7mm cal kits, 5-43
response for type-n cal kits, 5-43
response for user cal kit, 5-44

response time , 12-26
 restart sweep, 6-20
RESTORE DISPLAY (RESD), 8-30
 resume cal, 5-40
RESUME CAL SEQUENCE (RESC), 5-40
 return loss , 10-2, 10-3, 10-13
REV.ISQL'N ISQL'N STD (REVI), 5-50,
 5-53
REV.MATCH (LABEREVM), 5-60
REV.MATCH (SPECREVM), 5-58
REV. MATCH THRU (REVM), 5-50
REV.TRANS. (LABEREVT), 5-59
REV.TRANS. (SPECREVT), 5-58
REV. TRANS. THRU (REVT), 5-50
 rf input , 10-13
 rf out connector , 2-3
RF OUT on OFF (RFO ON|OFF), 6-16, 6-17
 rf output OFF P↓ , 2-8
 rf output ON P , 2-8
 right peak, 7-18
R+jX (CIRF RX), 7-28
 R_{r1} , 11-7
 R_{r2} , 11-7
 R_{t1} , 11-7
 R_{t2} , 11-7
Run , 8-6
 run/cont input , 2-10, 10-22

S

S11 1-PORT (CALI S111), 5-39
 s11 1-port cal, 5-46
S11B (LABES11B), 5-59
S11B (SPECS11B), 5-57
S11C (LABES11C), 5-59
S11C (SPECS11C), 5-58
S₁₁ one-port calibration , 12-42
[S11]: OPEN (CLASS11A), 5-46, 5-48, 5-52
S22 1-PORT (CALI S221), 5-39
 s22 1-port cal, 5-47
S22B (LABES22B), 5-59
S22B (SPECS22B), 5-58
S22C (LABES22C), 5-59
S22C (SPECS22C), 5-58
S₂₂ one-port calibration , 12-42
[S22]: OPEN (CLASS22A), 5-47, 5-49
 sample, 5-12
SAMPLE (DET SAM), 5-12
 sample detection mode, 12-18

sample mode, 12-16
 sample peak detection ON Smp , 2-8
 sample program disk , 10-24
 sampling , 6-7
 sampling rate, 12-28
 sampling time , 12-27
SAVE , 8-6
Save , 1-4
SAVE ASCII (SAVDASC), 8-33
SAVE BINARY (SAVDDAT), 8-32
 save color, 5-24
SAVE COLORS (SVCO), 5-24
 save data , 8-32
 save state , 8-32
SAVE USER KIT (SAVEUSEK), 5-41
 scale , 10-9
 scale coupling, 5-28, 5-30
 scale/div , 2-6
SCALE FOR [] (SCAF DATA|MEMO), 5-29
SCALE FOR [DATA] (SCAF DATA|MEMO),
 5-28
SCALE/DIV (SCAL), 5-27, 5-29
Scale Ref , 1-2, 5-27
 scaling , 12-6, 12-9
 scan speed of 31.5 kHz, 2-10
 scattering parameters , 12-10
SCRATCH , 8-7
 screen display , 2-4
 search, 12-30
Search , 1-3
SEARCH IN (WIDSIN), 7-20
SEARCH LEFT (SEAL), 7-19
SEARCH OUT (WIDSOUT), 7-20
SEARCH: PEAK (SEAM PEAK), 7-15
SEARCH: PEAK ALL (SEAM PKSA), 7-15
 search range, 7-25
SEARCH RANGE MENU , 7-17
SEARCH RIGHT (SEAR), 7-19
 search track, 7-16
 search tracking ONPeak,Max,
 Min,Targ,PksA,PksL,PksR, 2-6
SEARCH TRK on OFF (TRACK ON|OFF), 7-16
 second harmonic distortion , 10-10
SEGMENT , 6-4, 6-8, 8-14
 segment , 6-11, 12-21
SEGMENT DONE (SDON), 6-12, 6-14
SEGMENT: MKR→START (MKRSTAR), 6-11,
 6-13
SEGMENT QUIT (SQUI), 6-12, 6-14

SEGMENT: START (STAR), 6-12, 6-13
 selectivity, 12-17
 selectivity, 10-7
SELECT LETTER, 8-7
SELECT LETTER, 8-40
SELECT LETTER, 5-26
 serial number, A-2
 service function, 8-4
 service manual, 10-24
SERVICE MENU, 8-4
SET ADDRESSES, 8-19
SET CLOCK, 8-4
ERASE TITLE, 8-7
 set-up time, 12-26
SET ZO (SETZ), 5-41
 Sgn1, 2-6
 short, 5-63, 12-44
SHORT (CLASS11B), 5-46, 5-48, 5-52
SHORT (CLASS22B), 5-47, 5-49
SHORT (STANA), 5-43
SHORT [F] (STANB), 5-43
SHORT [M] (STANA), 5-43
SHORT (STDT SHOR), 5-63
 signal track, 7-16
 signal tracking ONSgn1, 2-6
SIGNAL TRK on OFF (SGTRK ON|OFF),
 7-16, 7-18
SINGLE (SING), 6-18
SLOPE (SLOPE), 6-15
SLOPE on OFF (SLOP ON|OFF), 6-15
 sloping, 6-15
 S1p, 2-8
 smith chart, 5-14
 Smith chart, 12-12
SMITH [Re Im] (FMT SMITH), 5-14
 Smp, 2-8
SMTH/POLAR MENU, 7-28
 smth/polar menu, 7-28
Source, 1-3
 source characteristics, 10-1
 source crosstalk, 10-3
 source match, 12-39, 12-40, 12-47, 12-48,
 12-52
 source match E_{SF} , 12-53
 source match E_{SR} , 12-53
SPACE, 8-7
SPACE, 5-26
SPAN (SPAN), 6-12, 6-14

Span, 1-3
 span value, 2-7
 s-parameter, 12-10
 s-parameter measurement, 5-6
S-PARAMETERS, 5-5
 s-parameter test set interface, 10-22
 s-parameter test set interface pin assignments
 , 10-23
 s.p.c, 10-1
 specifications, 10-1
 specify class, 5-57
SPECIFY CLASS, 5-57
SPECIFY:FWD.TRANS. (SPECFWDT), 5-58
SPECIFY OFFSET, 5-64
SPECIFY: S11A (SPECS11A), 5-57
SPECIFY: S22A (SPECS22A), 5-58
 spectral purity characteristics, 10-2
 spectrum analyzer, 5-9
SPECTRUM ANALYZER (SA), 5-9
 spectrum measurement, 5-16
 spectrum monitor, 12-18
SPECTRUM: S (MEAS S), 5-8
 split display, 5-20
SPLIT DISP ON off (SPLD ON|OFF), 5-20
SPLIT DISP ON off, 5-18
 spurious responses, 10-10
 S_{r1} , 11-7
 S_{r2} , 11-7
 S_{t1} , 11-7
 S_{t2} , 11-7
 stability, 10-5, 10-6
 standard, 12-43
 standard class assignment, D-15
STANDARD DEFINITION (CALC [1-7]),
 8-27
 standard list, 8-27
Start, 1-3
 start value, 2-7
 state, C-2
STATE (SAVDSTA), 8-32
 statistics, 7-26, 7-27
STATISTICS on OFF (MEASTAT ON|OFF),
 7-26, 7-27
 status notations, 2-8
STD DONE (DEFINED) (STDD), 5-64
STD NO.1 [] (DEFS 1), 5-57
STD NO.2 [] (DEFS 2), 5-57
STD NO.3 [] (DEFS 3), 5-57
STD NO.4 [] (DEFS 4), 5-57

STD NO.5 [] (DEFS 5), 5-57
STD NO.6 [] (DEFS 6), 5-57
STD NO.7 [] (DEFS 7), 5-57
STD NO.8 [] (DEFS 8), 5-57
STD OFFSET DONE, 5-61
STD TYPE: OPEN (STDT OPEN), 5-62
Step, 8-5
step key, 4-2
STEP SIZE (STPSIZE), 6-11
STEP SIZE AUTO man (CNTSAUTO ON/OFF),
 6-22
Stop, 8-6
STOP (STOP), 6-12, 6-13
Stop, 1-3
stop value, 2-7
storage, 10-20
storage device, 8-34
storage devices, C-1
STOR DEV[] (STODDISK, STODMEMO),
 8-33, 8-34, 8-36, 8-37
STOR DEV [] (STODDISK, STODMEMO),
 8-40, 8-41
sub-marker, 7-7
SUB MKR, 7-18, 7-19
SUB MKR (SMKR [1-7] ON), 7-3
SUB MKR 1 (SMKR1 ON/OFF), 7-7, 7-8
SUB MKR 2 (SMKR2 ON/OFF), 7-7, 7-8
SUB MKR 3 (SMKR3 ON/OFF), 7-7, 7-8
SUB MKR 4 (SMKR4 ON/OFF), 7-7, 7-8
SUB MKR 5 (SMKR5 ON/OFF), 7-7, 7-8
SUB MKR 6 (SMKR6 ON/OFF), 7-7, 7-8
SUB MKR 7 (SMKR7 ON/OFF), 7-7, 7-8
Svc, 2-8
Sweep, 1-3
sweep block, 1-3
sweep characteristics, 10-6, 10-12
SWEEP:HOLD (HOLD), 6-18
sweep table, 8-24
sweep time, 6-3, 6-6
SWEEP TIME (SWET), 6-3, 6-6
sweep time, 2-7, 10-12
SWEEP TIME AUTO man (SWETAUTO), 6-6
sweep type, 10-6, 10-12
SWEEP TYPE:LIN FREQ (SWPT LINF), 6-7
SWEEP TYPE MENU, 6-7

SWEEP TYPE MENU (SWPT
 LINF|LOGF|LIST|POWE), 6-4
swept Mode, 12-16
switch port match, 11-7
switch tracking, 11-7
SWP PARAM (LIMPRM), 8-16
SWP PARAM OFFSET (LIMIPRMO), 8-15
SWR, 5-15
SWR (FMT SWR), 5-15
SWR PHASE (CIRF SWR), 7-28
System, 1-3
system accessory, 9-5
systematic error, 12-39
systematic error, 11-6
SYSTEM CONTROLLER, 8-19
system controller, 8-19, 12-35, 12-36
system error model, 11-6
system overview, 12-2
system performance, 11-1
system rack, 9-5
T
talker, 12-34
Targ, 2-6
TARGET (SEAM TARG), 7-15
TARGET (SEATARG), 7-19
target search, 7-15, 7-19
task reference, 10-24
teflon, 5-41
temperature, 10-23
temperature>, 10-23
temperature drift, 10-12, 11-15
temperature stability, 10-1, 10-7
TERMINAL IMPEDANCE (TERI), 5-64
terminator key, 4-2
test set, 9-2
test set I/O interface, 2-11
TEXT MARKER (COLO TEXT), 5-23
third order inter-modulation distortion,
 10-10
threshold, 7-22, 7-24
THRESHOLD on OFF (PKTHRE ON/OFF),
 7-22, 7-24
threshold value, 12-32, 12-33
THRESHOLD VALUE (PKTHVAL), 7-22, 7-24
thru, 12-44
THRU (STANC), 5-43
THRU (STANE), 5-44
TIFF, C-3
time-gated spectrum analyzer (option 1D6),
 9-1

TIME HH:MM:SS (SETCTIME) , 8-10
 time stamp , 8-22, 8-30
TINT (TINT) , 5-25
 title, 5-21
 title , 2-9
TITLE (TITL) , 5-21
TOP MARGIN (TMARG) , 8-25
 T_r , 11-7
 trace noise , 10-5, 10-6
 tracking , 12-39, 12-42, 12-47, 12-48, 12-52
TRACKING AMKR (DMKR TRAC) , 7-5
 tracking Δ marker, 7-5
TRANS. DONE (TRAD) , 5-50, 5-53
Trans:FWD S21 [B/R] (MEAS S21) , 5-6
TRANS-MISSION (TRAN) , 5-53
TRANS-MISSION (TRANS) , 5-49
 transmission cal, 5-49, 5-53
 transmission coefficient , 12-52
 transmission/reflection test kit , 12-54
 transmission repeatability , 11-7
 transmission tracking drift , 11-7
 transmission tracking E_{TF} , 12-53
 transmission tracking E_{TR} , 12-53
Trans:REV S12 [B/R] (MEAS S12) , 5-6
 T_{rd} , 11-7
TRIG EVENT [] (TRGEVE POIN|SWE), 6-20
Trigger , 1-3
 trigger event, 6-20
TRIGGER: [FREE RUN] (TRGS
 INT|EXT|VID|MAN|GAT), 6-19
 trigger input , 2-11
 trigger polarity, 6-20, 12-24
 trigger polarity , 10-22
 trigger source, 6-19
 trigger source , 10-6, 10-12
 trigger type, 6-18
 trigger type , 10-6, 10-12
TRIG PLRTY POS neg (TRGP POS|NEG),
 6-20
 T_{sw} , 11-7
 T_t , 11-7
 T_{td} , 11-7
 two-port error correction ON C2 , 2-8
 two-port error model , 12-52
 type, 12-43
 typical , 10-1
U
 U , 11-7
 U_m , 11-7
 uncertainty , 10-12, 11-2

unit, 5-16
UNIT: dBm (SAUNIT DBM) , 5-16
 U_p , 11-7
 upgrade kit, 9-1
UPPER LIMIT (LIMU) , 8-16
 upper limit , 8-16
 user cal kit, 5-41
 user-defined cal kit, 12-43
USER KIT (CALC USED) , 5-41
 user level correction , 12-8
 user's guide , 10-24
Utility , 1-3

V

velocity factor, 5-41, 12-12
VELOCITY FACTOR (VELOFACT) , 5-41
 velocity factor , 5-41
 VGA , 10-23
VIDEO (TRGS VID) , 6-19
 video Averaging , 12-8
 video bandwidth, 5-34
 video bandwidth , 10-7
 video bandwidth (vbw) , 2-7
VIDEO BW (VBW) , 5-34
 video output terminal, 2-10
 video signal, 2-10
 video trigger , 12-8
VOLT (SAUNIT V) , 5-16

W

warm up time , 10-1, 10-23
WARNING (COLO WARN) , 5-23
WATT (SAUNIT W) , 5-16
 weight , 10-24
 width , 7-16
 width function, 7-20
WIDTHS [] (WIDT ON|OFF), 7-16
 width search, 12-30
WIDTHS on OFF (WIDT ON|OFF), 7-20
WIDTH VALUE (WIDV) , 7-20
 width value , 2-6
 windowing , 12-7

X

Xch, 2-6

Y

Y conversion, 12-11
Y:Refl (CONV YREF) , 5-10
Y:Trans (CONV YTRA) , 5-10

Z

Z conversion, 12-11

zero span, 6-24

ZERO SPAN (SPAN 0), 6-24

zooming , 7-11

ZOOMING APERTURE (ZMAPER), 7-11

Z:Refl (CONV ZREF) , 5-10

Z:Trans (CONV ZTRA) , 5-10

REGIONAL SALES AND SUPPORT OFFICES

If you need technical assistance with a Hewlett-Packard test and measurement product or application, please contact the Hewlett-Packard office or distributor in your country.

Asia Pacific:

Hewlett-Packard Asia Pacific Ltd
17-21/F Shell Tower, Times Square,
1 Matheson Street, Causeway Bay,
Hong Kong
(852) 2599 7070

Australia/New Zealand:

Hewlett-Packard Australia Ltd.
31-41 Joseph Street
Blackburn, Victoria 3130
Australia
131 347 ext. 2902

Canada:

Hewlett-Packard Canada Ltd.
5150 Spectrum Way
Mississauga, Ontario
L4W 5G1
(905) 206 4725

**In Europe, Africa and Middle East
please call your local HP sales office
or representative:**

Austria/East Central Europe:
(1) 25000-0

Belgium and Luxembourg:
(02) 778 34 17

Czech Republic:
(2) 471 7327

Denmark:
45 99 10 00

Finland:
(90) 88 721

France:
(1) 69.82.65.00

Germany:
(0180) 532 62-33

Greece:
(1) 7264045

Hungary:
(1) 252 4705

Ireland:
(01) 284 4633

Israel:
(03) 5380 333

Italy:
02 - 92 122 999

Netherlands:
(020) 547 6669

Norway:
(22) 73 56 00

Poland:
(22) 37 50 65

Portugal:
(11) 301 73 30

Russia:
(095) 956 2126

South Africa:
(011) 806 1000

Spain:
900 123 123

Sweden:
(08) 444 20 00

Switzerland:
(01) 735 7111

Turkey:
(212) 224 59 25

United Kingdom:
(01344) 366 666

**For European countries
not listed,
contact:**

Hewlett-Packard
International Sales Europe
Geneva, Switzerland
Tel: +41-22-780-4111
Fax: +41-22-780-4770

Japan:

Hewlett-Packard Japan Ltd.
Measurement Assistance Center
9-1, Takakura-cho, Hachioji-shi,
Tokyo 192, Japan
Tel: (81) 426 48 0722
Fax: (81) 426 48 1073

Latin America:

Hewlett-Packard
Latin American Region Headquarters
5200 Blue Lagoon Drive
9th Floor
Miami, Florida 33126
U.S.A.
(305) 267 4245/4220

United States:

Hewlett-Packard Company
Test and Measurement Organization
5301 Stevens Creek Blvd.
Bldg. 51L-SC
Santa Clara, CA 95052-8059
1 800 452 4844